

Rovalve

Standard and custom fabricated knife gates available in any weldable alloy and in many configurations.

Features

- Fabrication provides flexibility of design for today's process industries.
- Valves are designed and built to your exact specifications.
- Round, square or rectangular ported.
- Metal-to-metal (F20) and resilient seat (F17).
- Unidirectional or bidirectional.
- Select from various materials of construction.
 - 304 SS – 316 SS
 - 317L SS – Titanium
 - 310 SS – Monel®
 - Hastelloy® – 254SMO
 - Alloy 20
- Other special materials or combinations of materials available to suit your application.
- 2" to 24", 150 psi CWP.
- High or low pressure ratings available.
- MSS face-to-face standard to 24".
- Minimum face-to-face or other dimensions available as desired.

Advantages of Fabrication

Fully fabricated valve products give you flexibility of design and, in many instances, a more cost effective finished product. While fabrication may seem like the old way of doing things, it still has a major place in today's valve industry.

With a fabricated valve, the valve body flanges create a frame. This frame acts as an exoskeleton, surrounding and supporting the actual pressure vessel, the metal valve liner. While the liner is fully rated to the design pressure of the valve, excess weight or material found in a cast valve is unnecessary. If the application calls for the wetted parts to be hastelloy, the frame can be made from a less expensive alternative such as 316 SS, with appreciable savings.



Standard 150 psi CWP, round-port design shown

Each part of the valve body is made independently. The port flanges and top flange are cut from plate and the liner is formed from sheet. Once welded together, they make up an extremely rugged, fully integral, body assembly.

Technical Data

Size range: 2" to 24", 150 psi CWP

Larger sizes available designed to suit application up to and including 144".

General Applications

- For severe service and specialty applications
- Pulp and paper
- Recycle paper
- Chemical
- Petrochemical
- Power
- Mining
- Wastewater

Rovalve Fabricated F17 and F20 Knife Gate Valves

2" to 36"

Standard F17 and F20 Features

F17 has replaceable bidirectional perimeter mechanically retained resilient seat standard

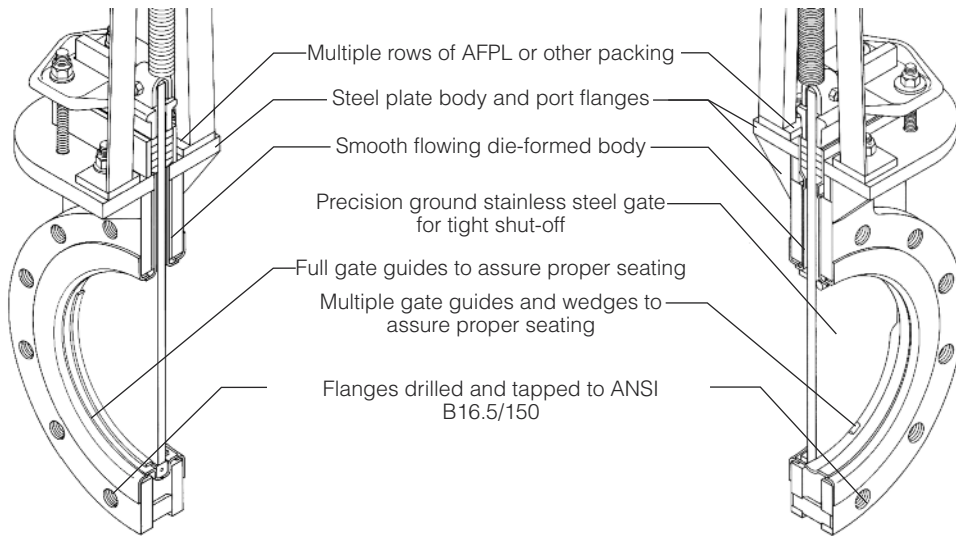
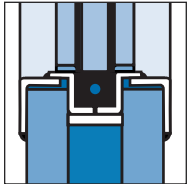

F20 has beveled gate to shear through solids, metal-to-metal seat is standard (O-ring available)

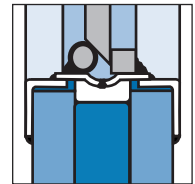

Code of Material

Item	A	B	C	D	F	H	K	Q
F17 Seat	Hycar (std)	Hycar (std)	Hycar (std)	Hycar (std)	Hycar (std)	Hycar (std)	Hycar (std)	Hycar (std)
F20 Seat	304	316	304	316	304	317L	317L	As Specified
Wetted body parts	304	316	304	316	Carbon steel	317L	317L	As Specified
Gate	304	316	304	316	304	317L	317L	As Specified
Stem	304	304	304	304	304	304	304	304
Flange faces	304	316	304	316	Carbon steel	317L	317L	Same as wetted parts
Flanges/Gussets	Carbon steel	Carbon steel	304	316	Carbon steel	Carbon steel	317L	As Specified
Packing gland	Cast	Cast ductile	304 ductile	316	Cast	Cast ductile	317L ductile	As Specified
Packing	AFPL	AFPL	AFPL	AFPL	AFPL	AFPL	AFPL	AFPL
Bolting	Plated steel	Plated steel	304	304	Plated steel	Plated steel	304	As Specified
Yoke	Carbon steel	Carbon steel	304	304	Carbon steel	Carbon steel	304	As Specified
Handwheel	Cast ductile	Cast ductile	Cast ductile	Cast ductile	Cast ductile	Cast ductile	Cast ductile	Cast ductile

Note:

AFPL, the standard packing, is an asbestos free Teflon® impregnated synthetic packing suitable for services up to 500°F and a pH of 3-11. Other packings include Teflon® (0-13 pH), food-grade Teflon® and our AFPH for temperatures up to 1200°F.

Dimensions and Weights, Standard Round-Port Valves (per MSS-SP81)

Size	A	B	C MSS	C MIN	D F17	E F17	D F20	E F20	Weight
2	8	6	1.88	1.75	13.75	16	11.5	14.25	33
3	8	7.5	2	1.75	17.63	20.88	15	17.63	39
4	8	9	2	1.75	19.25	23.5	16.63	20.25	38
6	12	11	2.25	1.75	24.38	30.75	20.63	26.25	72
8	12	13.5	2.75	2	28.38	36.75	25.25	32.88	115
10	16	16	2.75	2.13	32.88	43.38	29.5	39.13	165
12	16	19	3	2.5	36.88	50	33.5	45.13	245
14	20	21	3	2.63	41.88	56	39.13	52.75	330
16	20	23.5	3.5	2.63	45.75	61.88	43	58.38	470
18	20	25	3.5	3.25	49.38	67.38	46.63	64.13	545
20	20	27.5	4.5	3.5	53.13	72.88	49.63	68.75	795
24	30	32	4.5	3.75	62.25	86	59	82.13	1081
30	30	38.75	Note 1	Note 1	77.38	107	74.75	103.75	2100
36	30	46	Note 1	Note 1	89.88	126	89.13	121	3200

Contact your sales representative for details on non-standard designs.

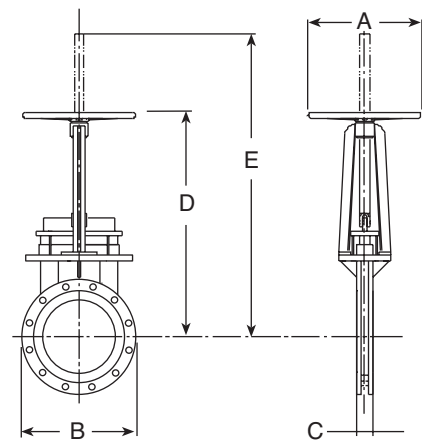

Notes:

- 30", 50# design, F-F = 4"
- 30", 125# design = 4⁵/₈"
- 36", 50# design, F-F = 4¹/₄"
- 36", 125# design = 5³/₄"

Tyco Flow Control (TFC) provides the information herein in good faith but makes no representation as to its comprehensiveness or accuracy. This data sheet is intended only as a guide to TFC products and services. Individuals using this data sheet must exercise their independent judgment in evaluating product selection and determining product appropriateness for their particular purpose and system requirements. TFC MAKES NO REPRESENTATIONS OR WARRANTIES, EITHER EXPRESS OR IMPLIED, INCLUDING WITHOUT LIMITATION ANY WARRANTIES OF MERCHANTABILITY OR FITNESS FOR A PARTICULAR PURPOSE WITH RESPECT TO THE INFORMATION SET FORTH HEREIN OR THE PRODUCT(S) TO WHICH THE INFORMATION REFERS. ACCORDINGLY, TFC WILL NOT BE RESPONSIBLE FOR DAMAGES (OF ANY KIND OR NATURE, INCLUDING INCIDENTAL, DIRECT, INDIRECT, OR CONSEQUENTIAL DAMAGES) RESULTING FROM THE USE OF OR RELIANCE UPON THIS INFORMATION. Patents and Patents Pending in the U.S. and foreign countries. Tyco reserves the right to change product designs and specifications without notice. All registered trademarks are the property of their respective owners. Printed in the USA.