

Rovalve

Bidirectional, resilient seated solid cast stainless steel knife gate provides value and performance with many standard features.

Features

- Two-way ZERO LEAKAGE shut-off from full vacuum to the rated pressure of 150 psi (water test).
- True bidirectional flow and shut-off, can be installed in either direction.
- Perimeter seat seals around the edge of the gate.
- Larger flow area, minimum pressure drop.
- Pressure against the gate is not required to achieve a seal.
- Unsurpassed low-pressure seal.
- Mechanically retained seat prevents pullout*.
- Seat is field replaceable.
- 316 solid cast stainless steel body.
- MSS face-to-face.
- Cast SuperYoke features
 - Top removal stem nut
 - Standard open and closed lockout positions
 - Heavy cross section I-beam legs

Full range of operators and accessories

- Handwheel (standard)
- Bevel gear
- Lock-Pin
- Quick-open lever (limited sizes)
- Air/hydraulic/spring cylinders
- Electric motor operators
- Control accessories
- Extension stems, floorstands, stem guides

* Patent number 5,653,423



Advantage S17 Knife Gates

Featuring an elastomeric perimeter seal, the S17 was designed from the beginning to handle pressure from either direction. It also has the benefits of drip tight shut-off and a larger flow area. Proven in thousands of applications worldwide, you will not find another perimeter seat design with more in-service experience.

Technical data

Size range : 2" thru 24" 150 psi CWP
at ambient temperatures

General applications

- Pulp and paper
- Chemical
- Petro-chemical
- Power
- Mining
- Waste water

Features

The S17 perimeter seat is different in many ways

The seat seals around the edge of the gate. The gate is mechanically pushed into the seat creating a perfect seal. Since pressure against the gate is not required to achieve a seal you get an unsurpassed low pressure seal, the same performance in both directions.

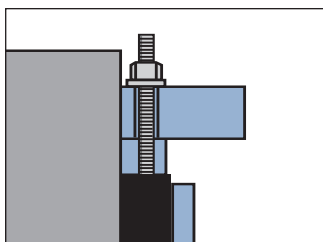
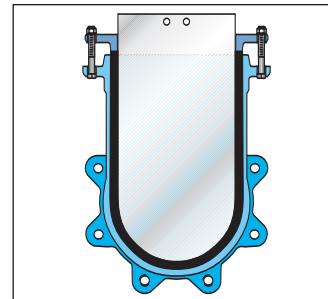
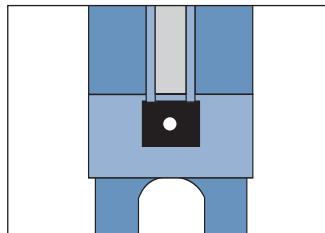

New mechanically retained seat prevents pullout

The patented mechanically retained seat improves the performance and extends the service range of the S17. A threaded rod is inserted into the elastomer seat serving a double purpose, adding stiffness to the elastomer and acting as the seat lock. Extending from the seat and through the packing gland, the rod is held in place with a locknut and washer. This prevents the seat from moving or being pulled out. Because it is mechanically retained, the seat is still easily field replaceable. Patent number 5,653,423

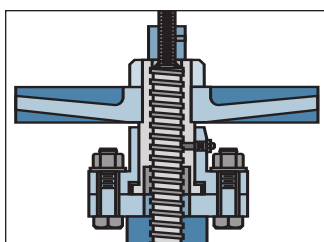

SuperYoke with Top-removal Stem Nut

To increase stem nut life and provide for easier maintenance, the SuperYoke includes a unique top removal encapsulated stem nut assembly. The stem nut is supported on both the top and bottom bearing surfaces, literally surrounded in a blanket of lubrication. Maintenance is simple with the encapsulated stem nut, replacement is easy and quick; remove the handwheel and retaining bolts, pull the retainer free, and then rotate the old stem nut off the stem. There is no need to remove the yoke assembly. Reverse the process to reassemble, and you are back in operation.

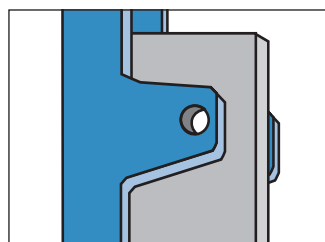

SuperYoke Standard with Open and Closed Lockouts

As an added feature, the SuperYoke has heavy cross section integral locking ears with a hole already in the gate to accept a sturdy pin for both the open and closed positions. Remember, these locking ears are standard on all sizes of handwheel operated valves; you do not have to order them separately. With a customer-supplied pin, you can lock the valve without further modification to the valve and at no extra cost!

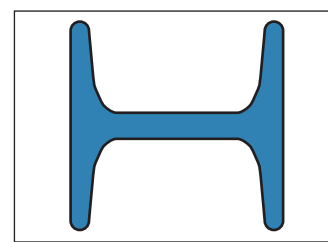

Heavy Cross Section I-Beam Legs on SuperYoke

Compare the yoke leg of the SuperYoke against a typical T-Bar yoke leg. Which would be stronger? Obviously, the SuperYoke with the cast I-Beam cross section is superior. You would have to work hard to bend or break this yoke!

Available Packing Arrangements

The Rovalve S17 is available with numerous optional packing types and special packing arrangements to assure superior performance.

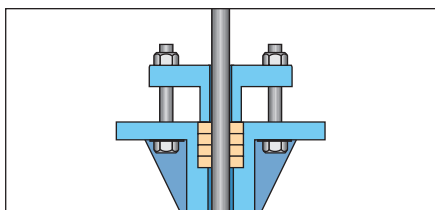

Standard Packing

The standard packing is an asbestos free Teflon® impregnated synthetic packing suitable for services up to 500°F and a pH of 3-11, other packings include Teflon® (0-13 pH), food-grade Teflon®.

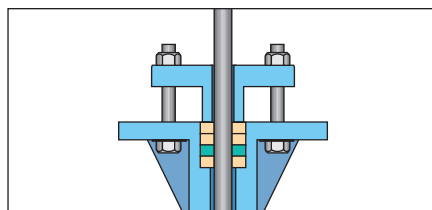

Enhanced Packing

The enhanced packing arrangement features Self-Mold SM636®, a pliable packing material that forms itself to the interior of the packing box, filling any voids.

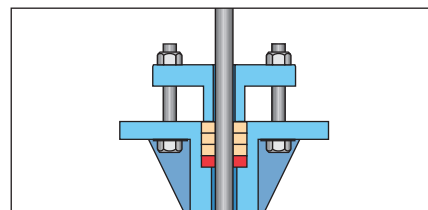

Packing Support Bar

The S17 can be equipped with a packing support bar or gate wiper for more critical applications.

Features

- Stroke stop-stud assembly allows gate/seat adjustment, prolongs seat life
- Cast ductile iron handwheel
- Self-locking handwheel retaining nut
- Encapsulated, top-removal, acid-resistant bronze stem nut smooth operation
- Cast SuperYoke
- Precision machined standard open and closed lockout positions
- Heavy cross-section 304 stainless steel stem, single-lead Acme threads for ease of operation
- Cast 316 stainless steel packing gland
- Bolts with locknuts used throughout
- Multiple rows of AFPL¹ or other packing
- 316 stainless steel gate
- Full port flow area through 8"
- Full gate guides to assure proper seating
- Cast 316 stainless steel body with machined gasket faces and flanges drilled and tapped to ANSI B16.5/150
- Replaceable, bi-directional, mechanically retained perimeter BUNA-N elastomer seat

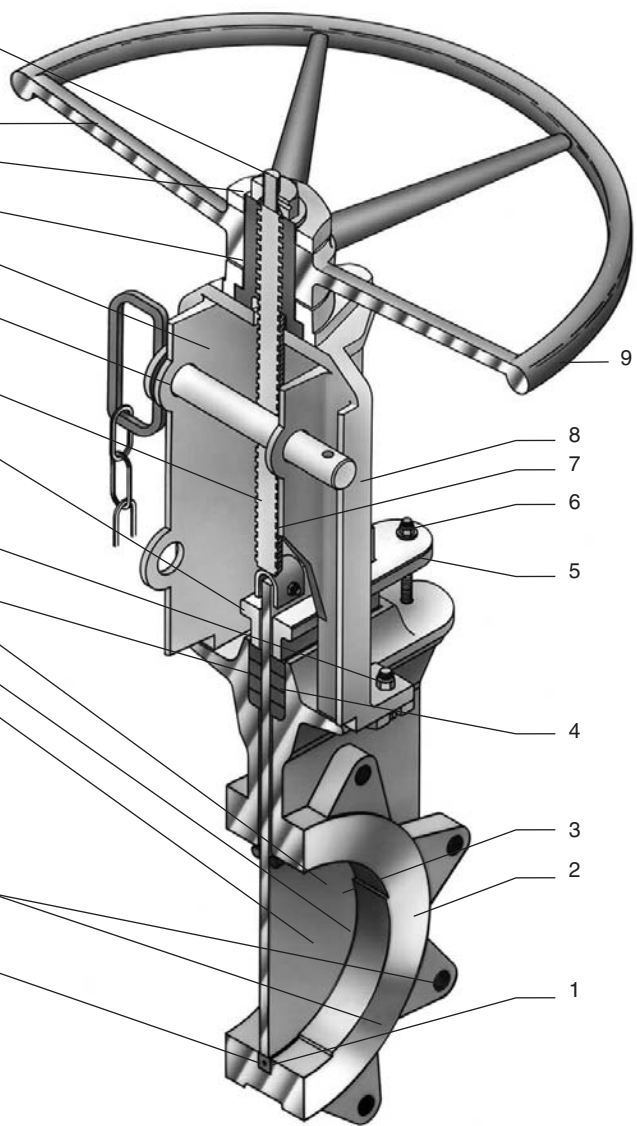

Notes

1. AFPL is an asbestos free Teflon® impregnated synthetic packing suitable for services up to 500°F and a pH of 3-11; other packings are available.
2. Other seat materials are available; please refer to the listing on page 4.
3. Teflon® is a registered trademark of E.I. du Pont de Nemours Company.

Code of Material

No.	Part	B	D
1	Seat	BUNA-N (std ²)	BUNA-N (std ²)
2	Cast body	Cast 316	Cast 316
3	Gate	316	316
4	Packing	AFPL ¹	AFPL ¹
5	Packing gland	Cast 316	Cast 316
6	Bolting	Plated steel	304
7	Stem	304	304
8	Yoke	Cast steel	Cast 304
9	Handwheel	Cast ductile	Cast ductile

Rovalve Figure S17 Resilient Seated Knife Gate Valve

2" thru 24"

Specifications

Rovalve Figure S17, 2" thru 24"

Bonnetless, knife gate valve, 150 psi design for 150 psi CWP, cast 316 stainless steel one piece body, cast 316 stainless steel one piece packing gland, MSS-SP81 face-to-face. Valve seating shall be provided by a mechanically retained resilient seat positioned to seal around perimeter of gate for uninterrupted flow, with zero leakage of water allowed in both directions from full vacuum to the full rated pressure of the valve. The resilient seat shall be molded or extruded BUNA-N with an internal stainless steel threaded rod inserted into the elastomer seat, serving a double purpose - adding stiffness to the elastomer and acting as the seat lock. To prevent atmospheric leakage, the valve features an adjustable packing assembly consisting of multiple layers of braided, asbestos-free Teflon® impregnated synthetic (AFPL*) or equal packing around gate evenly compressed by a one piece packing gland. The valve body to be lug style, drilled and tapped to ANSI B16.5/150 with machined raised gasket faces. Valve is equipped with a manual handwheel operator assembly featuring a cast ductile iron handwheel, a solid cast foot mounted yoke with a fully encapsulated acid resistant bronze stem nut which is completely replaceable from the top of the yoke without removing the yoke, and integral cast-in-place OPEN and CLOSED locking ears suitable for optional case hardened steel lock pin, including a 304 stainless steel rising stem. **Rovalve Figure S17 from Tyco Valves & Controls.**

AFPL is an asbestos free Teflon® impregnated synthetic packing suitable for services up to 500°F and a pH of 3-11, other packings are available.

Available seat materials

BUNA-N: Maximum continuous operating temperature 200°F.

EPDM: Maximum continuous operating temperature 300°F.

Hypalon: Maximum continuous operating temperature 200°F.

Fluoroelastomer: Maximum continuous operating temperature 400°F.

Consult factory for temperatures higher than 400°F.

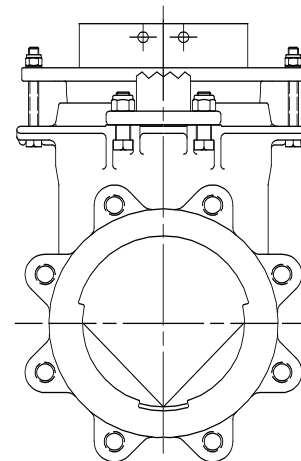

For throttling, the S17 is available with a V-Port option. The chart below shows the maximum C_v with standard and V-Port.

C_v Values

Valve Size	Flow Round Port	Area of Opening	Flow V-Port	Area of Opening
2	325	3.5	158	2.6
3	791	8.6	355	5.8
4	1209	13.2	631	10.3
6	2678	29.2	1420	23.1
8	4764	51.8	2386	41.1
10	6785	73.7	3239	58.8
12	9875	107.3	4472	85
14	12973	154.6	6190	123.7
16	15479	199.5	7559	158.2
18	19336	249.2	9542	200
20	23323	300.6	10943	229
24	32140	426.8	15723	328.9

Dimensions and Weights

A	B	C	D	E	Wt.
8	6.00	1.88	13.75	16.00	25
8	7.50	2.00	15.38	19.00	27
8	9.00	2.00	16.88	21.25	38
12	11.00	2.25	24.13	30.50	62
12	13.50	2.75	27.75	36.00	97
16	16.00	2.75	32.00	42.00	156
16	19.00	3.00	37.13	49.25	214
20	21.00	3.00	41.88	56.00	245
20	23.50	3.50	45.75	61.88	315
20	25.00	3.50	49.38	67.50	418
20	27.50	4.50	53.88	72.75	520
20	32.00	4.50	62.25	86.00	748

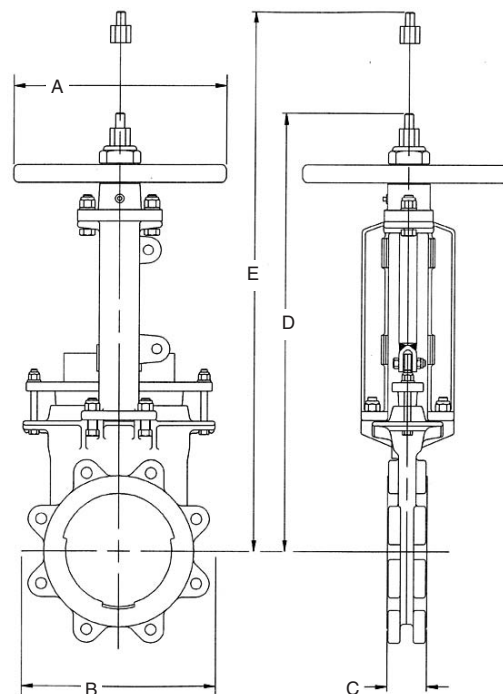

Reno Facility Phone: 777-359-4100

www.tycoflowcontrol.com

Tyco Flow Control (TFC) provides the information herein in good faith but makes no representation as to its comprehensiveness or accuracy. This data sheet is intended only as a guide to TFC products and services. Individuals using this data sheet must exercise their independent judgment in evaluating product selection and determining product appropriateness for their particular purpose and system requirements. TFC MAKES NO REPRESENTATIONS OR WARRANTIES, EITHER EXPRESS OR IMPLIED, INCLUDING WITHOUT LIMITATION ANY WARRANTIES OF MERCHANTABILITY OR FITNESS FOR A PARTICULAR PURPOSE WITH RESPECT TO THE INFORMATION SET FORTH HEREIN OR THE PRODUCT(S) TO WHICH THE INFORMATION REFERS. ACCORDINGLY, TFC WILL NOT BE RESPONSIBLE FOR DAMAGES (OF ANY KIND OR NATURE, INCLUDING INCIDENTAL, INDIRECT, OR CONSEQUENTIAL DAMAGES) RESULTING FROM THE USE OF OR RELIANCE UPON THIS INFORMATION. Patents and Patents Pending in the U.S. and foreign countries. Tyco reserves the right to change product designs and specifications without notice.