

CLARKSON L&M Valve Rovalve

Features

Choose from a variety of manual operators for maximum flexibility and value from your Clarkson, L&M Valve or Rovalve knife gate, slide gate or wedge gate valves.

Bevel Gear Actuator

Fully enclosed, permanently lubricated heavy duty bevel gear operators delivers high torque and smooth operation. Can be used to reduce rim pull or reorient handwheel to desired location.

Ratchet Operator

Perfect for tight locations. When space is at a minimum, use the ratchet feature to easily cycle your valve. If space allows, turn it a full 360 degree the lang handle decreases rim pull most efficiently. See page 2.

Chainwheels

Great for those high overhangs locations. Simply clamp onto the existing handwheel and drop the chain. The inherent hammer blow effect makes a sticky valve easy to operate. Clamp-on styles are available for different handwheel sizes, including bevel gear. Direct mount chainwheels are also available. Plated steel and stainless chain are optional.

Stem Extension, Extended Yokes

We can provide various stem extension assemblies designed to your application; Floorstands (rising and non-rising) floorboxes, extended yokes and others. See page 3 for details.

Optional manual actuators to suit your specific application needs.



Bevel Gear Actuator

Two sizes available, the BG3 three-to-one and the BG4 four-to-one. Each provides high torque to ease the operation of your valve.

Both bevel gear operators are fully enclosed, permanently lubricated heavy duty bevel gear operators delivering high torque and smooth operation.

BG3

- 3:1 gear ratio.
- 625 foot pounds torque.
- 22,000 pounds thrust.
- 12" or 24" diameter handwheels are standard depending on valve size (other sizes are available).
- Approximate weight 38 pounds.

BG4

- 4:1 gear ratio.
- 1,600 foot pounds torque.
- 15,000 pounds thrust.
- For use on any size up to 24", 150 psi CWP (for larger sizes, contact your sales representative).
- 18" diameter handwheel is standard (other sizes are available).
- Approximate weight of BG4 is 78 pounds.

Available factory mounted or as a conversion kit for field installation. The design of the Tyco bevel gear mount allows easy field adaptation without valve disassembly.

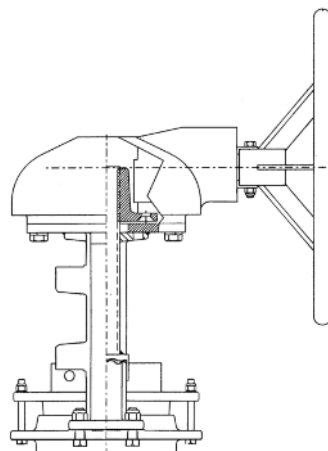

BG4 actuator assembly mounted the SUPERYOKE

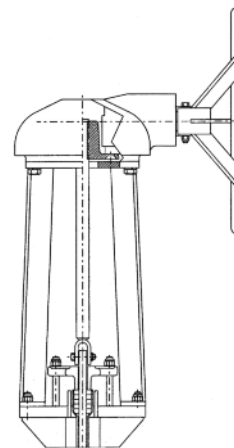

BG4 actuator assembly mounted on conventional yoke

Ratchet Operator

The optional Ratchet Operator assembly gives you easy operation where space is limited. It is provided with an extra long handle making the operation quick, smooth and easy. Great when the valve is close mounted to a tank or other obstruction.

Available on any model valve. Size is limited depending on differential pressure.

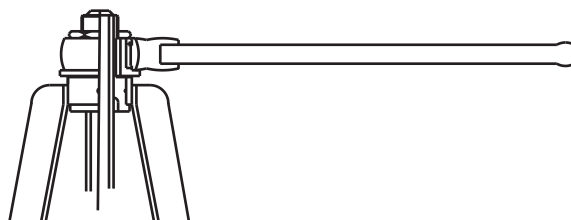

Chainwheel Operator

Clamp-on or direct mount, both provide easy access to those valves in high place. Available on any model valve.

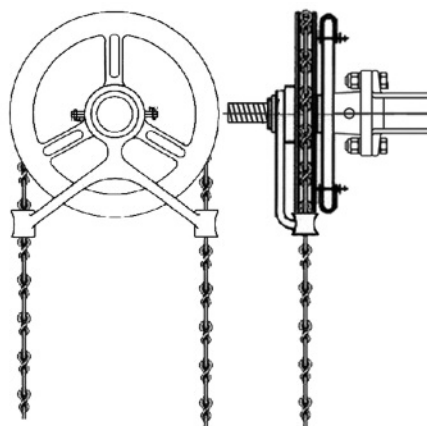

Stem Extensions and Floorstands

In order to properly design and price a complete stem extension assembly, certain details must be provided. They are:

- “W” dimension, Centerline of valve to base of floorstand, see detail “A” and “B”.
- “X” dimension, Centerline of valve to top of floor, see detail “C” and “D”.
- “Y” dimension, Centerline of valve to top of drive nut, see detail “E”.
- “Z” dimension, Centerline of valve to base of yoke, see detail “F”.
- “V” dimension, Centerline of valve to handwheel, see detail “G”.
- SG400 solid (nonadjustable) stem guide has a standard “L” dimension of 8". Others are available.
- AG400 adjustable stem guide has a standard “L” adjustable span of 2" to 10". Others are available.

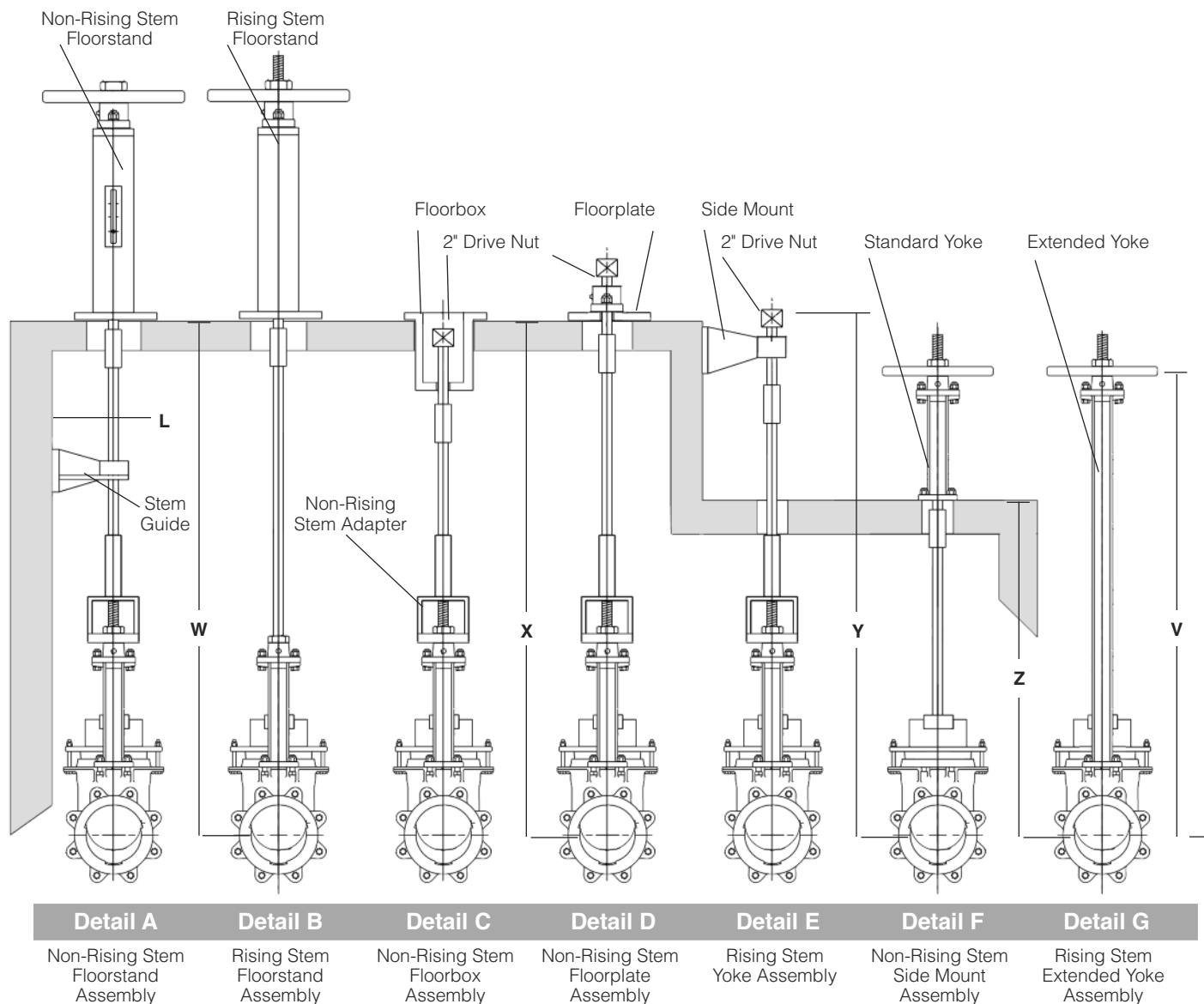

Notes:

1. Not all extensions are suitable for all valve types or sizes. Contact your sales representative for recommendation.
2. Valve size, differential pressure and length of extension all have impact on type of recommended extension assembly.
3. Details A, B, F and G are available with bevel gear, cylinder or motor actuators.
4. Stem guides are available as nonadjustable or adjustable.

Manual Actuators for Knife, Slide and Wedge Gate Valves

Linear Actuators

Tyco Flow Control (TFC) provides the information herein in good faith but makes no representation as to its comprehensiveness or accuracy. This data sheet is intended only as a guide to TFC products and services. Individuals using this data sheet must exercise their independent judgment in evaluating product selection and determining product appropriateness for their particular purpose and system requirements. TFC MAKES NO REPRESENTATIONS OR WARRANTIES, EITHER EXPRESS OR IMPLIED, INCLUDING WITHOUT LIMITATION ANY WARRANTIES OF MERCHANTABILITY OR FITNESS FOR A PARTICULAR PURPOSE WITH RESPECT TO THE INFORMATION SET FORTH HEREIN OR THE PRODUCT(S) TO WHICH THE INFORMATION REFERS. ACCORDINGLY, TFC WILL NOT BE RESPONSIBLE FOR DAMAGES (OF ANY KIND OR NATURE, INCLUDING INCIDENTAL, DIRECT, INDIRECT, OR CONSEQUENTIAL DAMAGES) RESULTING FROM THE USE OF OR RELIANCE UPON THIS INFORMATION. Patents and Patents Pending in the U.S. and foreign countries. Tyco reserves the right to change product designs and specifications without notice. All registered trademarks are the property of their respective owners. Printed in the USA.