



Cylinder actuators provide a versatile method for automating knife gate valves.

### Actuation Adds Advantage

As more processes and systems move to automated control and monitoring, the need for actuated knife gate and slide gate valves becomes apparent. Actuation provides remote, out-of-sight operation, faster cycling, lower operating costs, better process management and safer operation. Air and hydraulic cylinder actuators from Tyco Valves & Controls provide a versatile and cost effective method of automation.

### Available Types

We offer several cylinder operator types, each suitable for linear valve actuation.

- Standard cycle duty air cylinder (150 psi rated)
- High cycle duty air cylinder (250 psi rated)
- Heavy duty hydraulic (3000 psi rated)

### Available Configurations

- Double acting (standard)
- Single acting (spring)
  - Spring to retract rod
  - Spring to extend rod

### Options

- 17-4 PH SS rod
- Double rod end
- Adjustable stroke stops
- Oversized ports
- Water-fitted
- Stainless steel construction
- Epoxy coating
- High/Low temp seals
- Manual handwheel override

(Not all options are available on all cylinder types.)



Tyco Valves & Controls offers an excellent selection of air cylinder operators, with or without control packages, to suit your specific needs. Contact your sales representative today for assistance in creating your custom automated package.

### Technical Data

Type:	Standard duty air
Rating:	150 psi
Bore sizes:	2, 2.5, 3.25, 4, 5, 6, 7, 8, 10, 12, 14, 16, 18, 20, 22
Type:	High cycle duty air
Rating:	250 psi
Bore sizes:	2, 2.5, 3.25, 4, 5, 6, 7, 8, 10, 12, 14, 16, 18, 20
Type:	Heavy duty hydraulic
Rating:	3000 psi
Bore sizes:	2, 2.5, 3.25, 4, 5, 6, 8

## Advantage Actuation

Actuation provides remote, out-of-sight operation, faster cycling, lower operating costs, more precise process control, safer operation and added value.

**Remote actuation:** When a cylinder actuated valve is equipped with solenoid control valve, limit switches or positioner, you have complete process flexibility. For example, the valve can be actuated with the push of a button by a solenoid control valve and its position confirmed by the limit switches. More precise control can be provided by the use of a pneumatic or electro-pneumatic positioner. Add a feedback potentiometer and you have complete control.

**Faster cycling:** Normal cycling time for cylinder-actuated valves is far less than manual handwheel, seconds instead of minutes. Depending on the valve type, air cylinder operated valves can operate almost as fast as you want them to. We can also provide systems with self-contained charging tanks and big bore control valves that can open or close your valve in microseconds. Resilient seated valves, like the Clarkson slurry valve do have a practical speed limit of approximately 1" per second. This prevents overstressing or cutting the elastomer sleeves.

**Lower operating costs:** Faster operation saves time, and money. Quicker cycle times mean lower work force costs. Fully automated valves can be actuated, and the position confirmed, with the simple push of a button. There is no need to send someone on a long walk to turn the handwheel.

**Better process management:** Actuated valves can mean automated process and system control. By tying your valves into a process control loop, everything can be continually monitored and adjusted as needed, all from a main control room. This gives you better product output and process repeatability.

**Safer operation:** With a complete actuation package, you do not have to depend on the "human factor" to assure complete closure. With position indication limit switches or feedback potentiometers, you always know the valve position.

**Added value:** The linear action of knife gate and slide gate valves is easily adapted to inexpensive, low maintenance, air or hydraulic cylinders. Actuated valves, while initially more expensive than

manual handwheel operated valves, help provide long-term value and return on investment.

**Complete control accessories:** A complete line of control accessories is available to fully automate your valve:

### Control Valves

- Solenoid control valves
- Manual control valves
- 3-way or 4-way
- Single solenoid (energize to open or closed)
- Dual solenoid
- Manual override for local operation of solenoid control valves
- Rubber, copper or SS piping
- Specify desired NEMA rating

### Mechanical Limit Switches

- SPDT, DPDT
- Open, closed, other positions
- Specify desired NEMA rating

### Proximity Limit Switches

- SPDT
- Open, closed, other positions
- Brass, stainless or plastic
- Specify desired NEMA rating

### Positioners

- 3-15 psi pneumatic
- 4-20 mA electro-pneumatic
- Feedback potentiometers
- Intelligent positioners with HART® protocol

### Other Available Options

- Filter/regulator sets
- Air booster (doubles available air up to 150 psi)
- Speed controls
- Mufflers

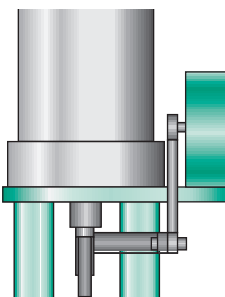
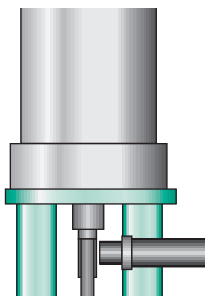
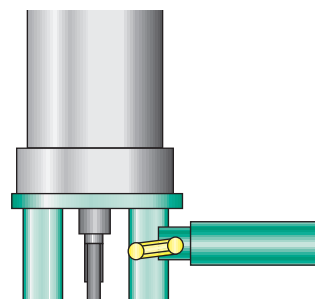
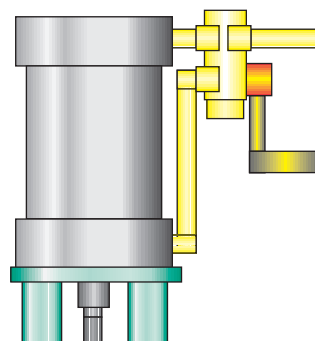

## Applying Cylinder Actuators

The proper application of cylinder actuators to a Tyco Valves & Controls knife gate product is fairly simple. Linear cylinders operate on the principle of thrust. The thrust of the cylinder must overcome the forces within the valve to allow proper operation. This thrust equates to a cylinder bore size.

### Double Acting Cylinder Actuator

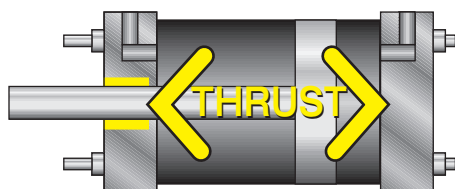

**Sizing:** Cylinder sizes for Tyco Valves & Controls knife gate valves differ depending on valve type and application conditions. Because of their design, the Clarkson slurry and the L&M Valve polymer lined knife gate valves have a minimum recommended cylinder size. Cylinder sizes for other valve types are application based. In all cases, to assure proper cylinder sizing, we need as minimum information:

- Maximum differential pressure.
- Minimum available air or hydraulic pressure.
- Media (or characteristics).

To determine the minimum cylinder bore size, the thrust required to cycle the valve is calculated using the maximum differential pressure and adding in the inherent valve thrust of the particular valve type using the following standard formula:

$$Av(DP)Fv+Fs=T$$

**Av**=Nominal Valve Area

**DP**=Differential Pressure

**Fv**=Valve Factor

**Fs**=Inherent Valve Thrust

**T**=Calculated Thrust

The resulting thrust (T) is then divided by the available air or hydraulic pressure. This gives us the minimum piston area (less the area of the piston rod), which is then converted to the closest cylinder bore size (always rounding up). The above information is provided as reference only, to assure proper sizing, contact your sales representative.

In addition to cylinder size, other factors may affect the correct cylinder selection:

- Number of cycles.
- Double or single acting.
- Desired stroke speed.
- Other media factors that may affect thrust load.

**Number of cycles:** If the application calls for multiple cycles per minute or hour, it would be advisable to select the high cycle duty cylinder for longer service life versus the standard cycle duty cylinder.

### Double and single acting air cylinders:

The standard cylinder is double acting; air is used both to retract and extend the rod. If the application calls for FAIL LAST POSITION UPON LOSS OF AIR, then a double acting cylinder will do the job. However, if AIR FAIL OPEN or AIR FAIL CLOSED UPON LOSS OF AIR is specified, then a single acting, spring cylinder is required. Both spring to retract (FAIL OPEN) or spring to extend (FAIL CLOSE) are available in either the standard cycle duty or high cycle duty designs. Please keep in mind, spring cylinder bore sizes are inherently larger compared to double acting styles. Additionally, they do have a practical limit. If the cylinder size becomes too big, then a FAIL CLOSE or OPEN air reservoir system can be provided.

**Speed of stroke:** Often an overlooked factor and one that can create confusion in air cylinder applications is how fast will the cylinder stroke. Speed is affected by many things including air pressure, Cv values of the control valve, airline size, and air volume to the cylinder. The higher the Cv, the faster the stroke, provided the airline size carries enough volume at sufficient pressure. The standard control valves offered by Tyco Valves & Controls provide a moderate stroke speed, but we can also put together control packages with extremely fast stroke times, measured in microseconds, or most any speed desired. Resilient seated valves, like the Clarkson slurry valve, do have a practical speed limit of approximately 1" per second.

### Spring to extend (close) cylinder actuator

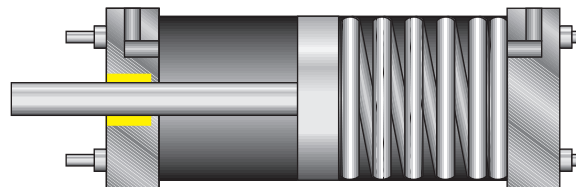

This helps prevent overstressing or cutting the elastomer sleeves. Let us know your specific need and we will recommend a suitable control valve.

**Other factors:** Many other factors can affect the cylinder size and selection. They include:

- Media: wet or dry.
- Media: high or low solids.
- Packing type: soft or hard.
- Liner and/or seat type.
- Temperature fluctuations.

If you have any doubts, check with your sales representative.

**Hydraulic cylinders:** The application and sizing of hydraulic cylinders is the same as air cylinders. Normally, the available hydraulic operating fluid is much higher than air pressure, so the cylinder size is greatly reduced.

**Optional cylinder mountings:** Many times, the required thrust for a particular valve may be too much for a practical cylinder bore size. In that situation, dual side mounted cylinders can be used. Example: A 16" knife gate has a required thrust load of 11,000 pounds, but only 40 psi air is available. This equals a 20" bore cylinder size. An option is to use two 12" bore cylinders that put out more thrust than a single 20" cylinder, and can actually cost less in some situations. Additionally, many times the overall length of a cylinder actuated knife gate can be too high to fit in a constrained space. Again, dual side mounted cylinders can be used, reducing the centerline to top dimension considerably.

**Air boosters:** Another method to help reduce cylinder bore size is through the use of an air booster. These devices can actually double the available air pressure up to the rated pressure of 150 psi. Using the example above and boosting the air to 80 psi reduces the required cylinder size to a single 14" bore.

# Cylinder Actuators

2" to 22" AC Bore Size, 2" to 8" HC Bore Size

## Standard Cycle Duty Cylinder Dimension and Weights

Bore size	A Length + Valve Size	B Rod diameter	C Cylinder head (sq)	D Tie-rod thread	E Tie-rod B.C.	P Inlet port (NPT)	Cylinder wt.	Plus Pounds per inch of valve size
2.5	3.63	0.63	3	5/16 - 24	3.1	1/4	6	0.47
3.25	3.63	1	4	3/8 - 24	3.9	1/4	9.4	0.6
4	4.00	1	4.5	3/8 - 24	4.7	1/4	16.1	0.81
5	3.63	1	5.5	1/2 - 20	5.8	1/4	24.2	1.01
6	3.88	1	6.5	1/2 - 20	6.9	1/4	33.6	1.12
7	3.88	1	7.5	5/8 - 18	8.1	3/8	48.4	1.61
8	5.5	1	8.5	5/8 - 18	9.1	3/8	62.3	2.22
10	5.5	1	10.63	3/4 - 16	11.2	3/8	104.5	2.65
12	6.38	1.38	12.75	3/4 - 16	13.3	1/2	172.4	3.37
14	6.38	1.38	14.75	7/8 - 14	15.4	1/2	270.1	3.95
16	6.63	1.75	17	1 - 14	17.8	1/2	379.7	6.1
18	7.00	2	19	1 1/8 - 12	19.8	3/4	521.0	7.1
20	7.00	2	21	1 1/4 - 12	22.3	3/4	666.5	10.23

## High Cycle Duty Cylinder Dimension and Weights

Bore size	A Length + Valve Size	B Rod diameter	C Cylinder head (sq)	D Tie-rod thread	E Tie-rod B.C.	P Inlet port (NPT)	Cylinder wt.	Plus Pounds per inch of valve size
2.5	4.75	0.63	3	5/16 - 24	3.1	3/8	9.7	0.47
3.25	5.63	1	3.75	3/8 - 24	3.9	1/2	18.4	0.71
4	5.63	1	4.5	3/8 - 24	4.7	1/2	26.2	0.79
5	6	1	5.5	1/2 - 20	5.8	1/2	40.8	1
6	6.63	1.38	6.5	1/2 - 20	6.9	3/4	60.6	1.7
8	7	1.38	8.5	5/8 - 18	9.1	3/4	104	2.2
10	8.5	1.75	10.63	3/4 - 16	11.2	1	188	3.7
12	9	2	12.75	3/4 - 16	13.3	1	285	4.3
14	10.38	2.5	14.75	7/8 - 14	15.4	1 1/4	479	5.9
16				Contact Sales				
18				Contact Sales				
20				Contact Sales				
22				Contact Sales				

## Hydraulic Cylinder Dimension and Weights

Bore size	A Length + Valve Size	B Rod diameter	C Cylinder head (sq)	D Tie-rod thread	E Tie-rod B.C.	P Inlet port (NPT)	Cylinder wt.	Plus Pounds per inch of valve size
2	6.13	1	3	1/2 - 20	2.3	1/2	9.7	0.47
2.5	6.25	1	3.5	1/2 - 20	3.6	1/2	18.4	0.71
3.25	7.38	1.38	4.5	5/8 - 18	4.6	3/4	26.2	0.79
4	7.75	1.75	5	5/8 - 18	5.4	3/4	40.8	1
5	8.75	2	6.5	7/8 - 14	7	3/4	60.6	1.7
6	10.13	2.5	7.5	1 - 14	8.1	1	104	2.2
7	10.5	3	8.5	1 1/8 - 12	9.3	1 1/2	188	3.7
8	11.63	3.5	9.5	1 1/8 - 12	10.6	1 1/2	285	4.3

Note: Dimensions are for reference only. Contact your sales representative for certified dimensional information.

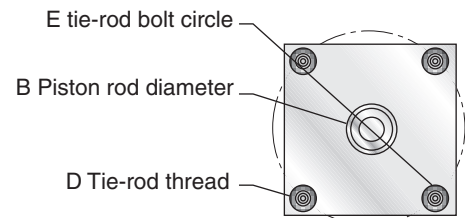
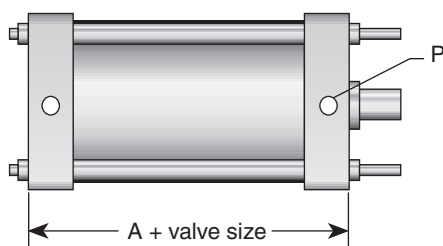

Tyco Flow Control (TFC) provides the information herein in good faith but makes no representation as to its comprehensiveness or accuracy. This data sheet is intended only as a guide to TFC products and services. Individuals using this data sheet must exercise their independent judgment in evaluating product selection and determining product appropriateness for their particular purpose and system requirements. TFC MAKES NO REPRESENTATIONS OR WARRANTIES, EITHER EXPRESS OR IMPLIED, INCLUDING WITHOUT LIMITATION ANY WARRANTIES OF MERCHANTABILITY OR FITNESS FOR A PARTICULAR PURPOSE WITH RESPECT TO THE INFORMATION SET FORTH HEREIN OR THE PRODUCT(S) TO WHICH THE INFORMATION REFERS. ACCORDINGLY, TFC WILL NOT BE RESPONSIBLE FOR DAMAGES (OF ANY KIND OR NATURE, INCLUDING INCIDENTAL, DIRECT, INDIRECT, OR CONSEQUENTIAL DAMAGES) RESULTING FROM THE USE OF OR RELIANCE UPON THIS INFORMATION. Patents and Patents Pending in the U.S. and foreign countries. Tyco reserves the right to change product designs and specifications without notice. All registered trademarks are the property of their respective owners. Printed in the USA.