



The unique design benefits of the M202 slide gate valve, with a four-piece replaceable polymer liner, offer reliability and long life in a wide variety of tough applications.

#### Features

- Four-piece replaceable polymer liner.
- Standard leak rate per MSS, not to exceed 40 cc of water per inch of diameter per minute at 40 psi.
- Every valve is leak tested to in both directions.
- Can be installed without worry as to direction of flow.
- 100% Full port opening reduces pressure drop allowing greater flow and minimizing wear.
- Liner provides all-around gate support.
- Liner prevents lateral movement of the gate, giving you longer packing life and a consistent valve seal.
- Positive seal packing chamber.

#### Full range of operators and accessories

- Handwheel (standard)
- Bevel gear (recommended 10" and larger)
- Lock-Pin for open, closed or both
- Air/hydraulic/spring cylinders
- Electric motor operators
- Control accessories
- Extension stems, floorstands, stem guides



#### The M202 is Like No Other

As you can see, the M202 is not an ordinary slide gate valve. Offering you superior performance in flow, shut-off, flexibility both in design and installation, packing life, and overall maintenance, the M202 can truly be called a Universal Valve.

#### Technical data

Size range : 2" thru 24" 150 psi  
CWP/at ambient temperature  
: Sizes above 24" designed to the application

Illustration shown with optional "Tear-Drop" port for throttling. Standard valve is round port.



Total Flow Control Solutions

L&M Valve is either a trademark or registered trademark of Tyco International Services AG or its affiliates in the United States and/or other countries. All other brand names, product names, or trademarks belong to their respective holders.

# L&M Valve - M202 Replaceable Polymer Lined Slide Gate

3" thru 24"

## Specification

Bonnetless, Universal Slide Gate Valve, 150 psi design for 150 psi CWP, wafer type with BIDIRECTIONAL shut-off up to the full rated pressure of 150 psi CWP. Valve shall have a maximum leakage rate of water of no more than 40 CC per inch of diameter at 40 psi in both directions without the use of O-rings. Valve shall have 100% FULL PORT FLOW AREA with no guides or wedges obstructing the port. The gate is a slide through design with a full port orifice cut in the valve gate. When valve is open, this cut-out will align with the valve port. When closed, the gate slides through the valve, creating a shut-off as the gate blank seats against the liner. The liner shall be four-piece field replaceable resilient material suitable for the application, completely lining the interior of the valve body, and totally supporting the gate. To prevent atmospheric leakage, the valve features an adjustable packing assembly at each end consisting of multiple layers of braided packing around gate, evenly compressed by one-piece packing glands. The body material shall be fabricated carbon steel or as suitable for the application and shall be drilled and tapped to ANSI B16.5/150 flange drilling. Valve is equipped with a manual handwheel operator assembly featuring a cast ductile iron handwheel, a solid cast foot mounted yoke with an acid resistant bronze stem nut, including a 304 stainless steel rising stem. **Specify the L&M Valve Model M202 from Tyco Valves & Controls.**

## Available Liner Materials

The four-piece liner of the M202 Series provides you excellent performance, long service life and ease of maintenance. The liners are precision cut, placed into the valve frame and bonded with a silicone compound to assure perfect alignment and a superior seal. Available in different materials to suit many applications.

- UHMWPE (180°F) - Ultra-High-Molecular-Weight Polyethylene has excellent chemical, abrasion and impact resistant properties with a good temperature range. It is widely used in the pulp and paper, textile, packaging and mining industries.
- Polypropylene (225°F) - A thermoplastic polymer with good impact and fatigue properties. It is resistant to acids, alkalies and solvents.
- PTFE (Teflon®) (350°F) - A polytetrafluoroethylene plastic with superior chemical resistant properties at elevated temperatures. It has excellent anti-stick properties, however it has a relatively poor resistance to wear and is not recommended for abrasive applications.

## Dimensions and Weights

Size	A	B	C	D	E	F	G
2"	12	6 <sup>3</sup> / <sub>8</sub>	2 <sup>1</sup> / <sub>2</sub>	2	21 <sup>1</sup> / <sub>8</sub>	24 <sup>1</sup> / <sub>8</sub>	14
3"	12	7 <sup>7</sup> / <sub>8</sub>	2 <sup>1</sup> / <sub>2</sub>	3	22 <sup>7</sup> / <sub>8</sub>	26 <sup>7</sup> / <sub>8</sub>	16 <sup>1</sup> / <sub>2</sub>
4"	12	9 <sup>3</sup> / <sub>8</sub>	2 <sup>1</sup> / <sub>2</sub>	4	24 <sup>5</sup> / <sub>8</sub>	29 <sup>5</sup> / <sub>8</sub>	19
6"	16	11 <sup>3</sup> / <sub>8</sub>	2 <sup>3</sup> / <sub>4</sub>	6	28 <sup>1</sup> / <sub>2</sub>	35 <sup>1</sup> / <sub>2</sub>	24 <sup>3</sup> / <sub>4</sub>
8"	16	13 <sup>7</sup> / <sub>8</sub>	3 <sup>1</sup> / <sub>4</sub>	8	31 <sup>1</sup> / <sub>4</sub>	39	29 <sup>1</sup> / <sub>2</sub>
10"	24	16 <sup>3</sup> / <sub>8</sub>	3 <sup>1</sup> / <sub>4</sub>	10	35	44 <sup>1</sup> / <sub>4</sub>	34 <sup>1</sup> / <sub>2</sub>
12"	24	19 <sup>3</sup> / <sub>8</sub>	3 <sup>1</sup> / <sub>2</sub>	12	39 <sup>1</sup> / <sub>2</sub>	51 <sup>3</sup> / <sub>4</sub>	41 <sup>1</sup> / <sub>2</sub>
14"	24	21 <sup>3</sup> / <sub>8</sub>	3 <sup>1</sup> / <sub>2</sub>	14	43	57 <sup>1</sup> / <sub>4</sub>	47
16"	24	23 <sup>7</sup> / <sub>8</sub>	3 <sup>3</sup> / <sub>4</sub>	16	46 <sup>3</sup> / <sub>4</sub>	63	53
18"	24	25 <sup>3</sup> / <sub>8</sub>	3 <sup>3</sup> / <sub>4</sub>	18	56 <sup>1</sup> / <sub>4</sub>	67 <sup>1</sup> / <sub>8</sub>	58
20"	24	27 <sup>7</sup> / <sub>8</sub>	4 <sup>1</sup> / <sub>2</sub>	20	59 <sup>1</sup> / <sub>2</sub>	72 <sup>3</sup> / <sub>8</sub>	63
24"	24	32 <sup>3</sup> / <sub>8</sub>	4 <sup>1</sup> / <sub>2</sub>	24	71	87 <sup>7</sup> / <sub>8</sub>	73

\*\* Dimensions for sizes 18" and larger are for valves with bevel gear operator.

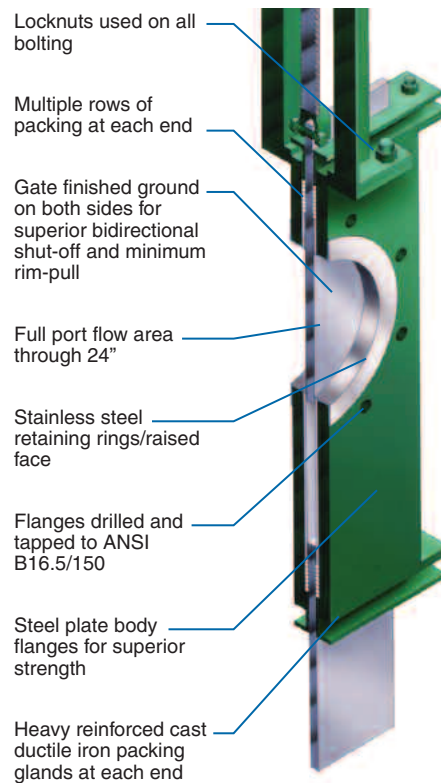

The four-piece field replaceable polymer liner, available in UHMWPE, Teflon® and Polypropylene, supports gate on all sides

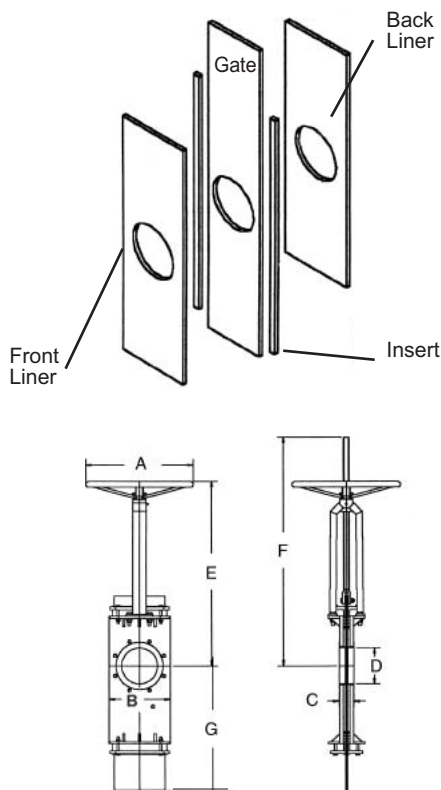

## Tyco Valves & Controls

Reno Facility Phone: 775-359-4100

www.tycovalves.com

Tyco Flow Control (TFC) provides the information herein in good faith but makes no representation as to its comprehensiveness or accuracy. This data sheet is intended only as a guide to TFC products and services. Individuals using this data sheet must exercise their independent judgment in evaluating product selection and determining product appropriateness for their particular purpose and system requirements. TFC MAKES NO REPRESENTATIONS OR WARRANTIES, EITHER EXPRESS OR IMPLIED, INCLUDING WITHOUT LIMITATION ANY WARRANTIES OF MERCHANTABILITY OR FITNESS FOR A PARTICULAR PURPOSE WITH RESPECT TO THE INFORMATION SET FORTH HEREIN OR THE PRODUCT(S) TO WHICH THE INFORMATION REFERS. ACCORDINGLY, TFC WILL NOT BE RESPONSIBLE FOR DAMAGES (OF ANY KIND OR NATURE, INCLUDING INCIDENTAL, INDIRECT, OR CONSEQUENTIAL DAMAGES) RESULTING FROM THE USE OF OR RELIANCE UPON THIS INFORMATION. Patents and Patents Pending in the U.S. and foreign countries. Tyco reserves the right to change product designs and specifications without notice.