

KEYSTONE

Before installation or maintenance, these instructions must be fully read and understood.

Please read these instructions carefully.



This symbol indicates important messages and safety instructions.

Potentially dangerous practices:

- disregarding instructions.
- improper use of product.
- use of insufficiently qualified personnel.

Application pressure/temperature must not be higher than the pressure/temperature limits shown on the technical data sheet.

Application medium must be in accordance with the Keystone Chemical Compatibility list.



Introduction

The Keystone Series 61 is a rubber lined butterfly valve which has a maximum working pressure of 235 psi over a temperature range of -20°F to +300°F, depending on seat and body material. The Series 61 has a two-piece design which enables the use of a one-piece disc stem. The one-piece disc stem provides the minimum possible flow restriction when the valve is fully open.

Flange and pipeline compatibility

Series 61 valves are suitable for use with flanges according to ANSI 150. Series 61 valves are intended to be clamped between flanges attached to the pipeline.

The minimum allowable pipeline bore at the flanges shall be the “Q” dimension shown in the valve data sheet plus adequate allowance to ensure the disc edge does not interfere with the pipeline bore.



Safety related information

1. For questions regarding any aspect of Series 61 valves, contact your local Tyco Flow Control sales office for guidance.
2. Only use properly qualified personnel for installation and maintenance.
3. Ensure that the pipeline is fully drained or vented before removing the valve from the pipeline.
4. Use appropriate protective equipment/clothing, such as goggles, safety shoes, industrial gloves.
5. When used on line fluids with a temperature of 176°F or more, the valve body can become very hot and should not be handled without appropriate protection.
6. The ductile iron body material, is a known brittle material and heavy impacts such as blows with a steel headed hammer should be avoided. This is particularly important for applications between -20°F and 32°F.
7. This product is not intended for use in areas where external fire is a potential hazard.
8. The piping design must take into account the following factors and any other factors which are not listed here, but known to be relevant to the safe operation of the installation.
 - 8.1. Valve weights which are shown in the technical data sheet.
 - 8.2. Formation of condensate in gas pipelines.
 - 8.3. Elimination of turbulence and vortex potential at the valve.
 - 8.4. Pipeline vibrations.
 - 8.5. The piping design should preclude the occurrence of water hammer at the valve.
9. The valve design has not taken into account earthquake loading or traffic vibration.
10. The normal shelf life of the Series 61 valve seat is 5 years under clean, dry ambient and conditions without UV exposure prior to installation.
11. Tighten all flange bolts as per the nominated flange standards using the diagonal sequence method.

tyco / Flow Control

Total Flow Control Solutions™

Installation Instructions

Installation in pipeline

Series 61 valves are bi-directional and there is no need to identify upstream and down stream orientation. Series 61 valves can be installed in vertical or horizontal pipelines and any intermediate orientation.

There is no restriction on the valve stem position (vertical, horizontal or oblique), although for slurry service and media, which have a tendency to deposit sediment, the recommended installation position is with the stem horizontal and the lower disc edge opening downstream.

Do not use flange gaskets or sealing compounds. The Keystone seat face design eliminates the need for gaskets.

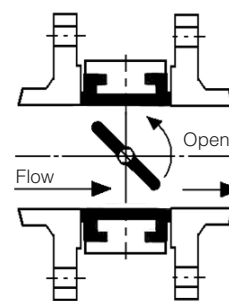

Preferred Mounting

Installation in an existing system

1. Check that the gap between the flanges can accommodate the valve face to face dimension.
2. Spread the flanges using suitable tooling such as flange spreaders to enable ease of insertion of the valve between the flanges.

⚠ Warning: Do not use the valve as a lever.

3. Open the valve until the disc is free of the seat but still within the valve body (about 5° open).
4. Loosely insert two or more flange bolts through the holes in the lower part of the flanges to help support the valve.
5. Carefully slide the valve between the flanges, center the valve body with the pipeline axis, and insert the remaining flange bolts.
6. Open the valve fully, checking that the disc edge does not interfere with the pipeline bore.
7. Remove any flange spreaders that have been used and at the same time tighten the flange bolts "hand tight". Ensure that the valve remains centered to the pipeline axis by slowly closing the valve (clockwise rotation of the disc stem) to check that adequate clearance has been maintained between the disc edge and the pipeline bore.
8. Re-open the valve (counter clockwise rotation of the disc stem) and tighten all flange bolts as per flange standards using the diagonal sequence method.
9. Operate the valve to the desired position.

Existing system

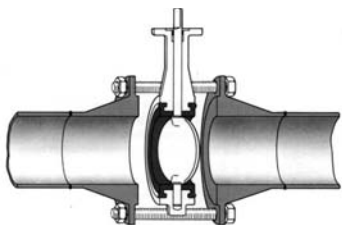

1. Spread the flanges with the adequate tooling. Insert some flange bolts to locate the valve.

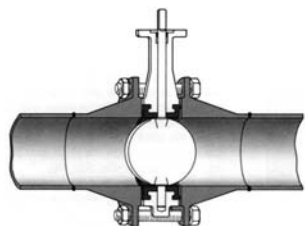

2. Open the valve and remove the flange spreaders.

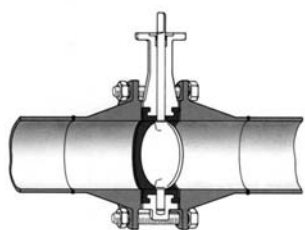

3. Close the valve clockwise, return to open position and cross-tighten all bolting.

New system

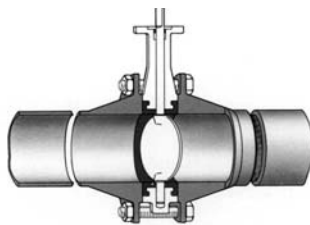

1. Center a flange-valve-flange assembly between the pipes.

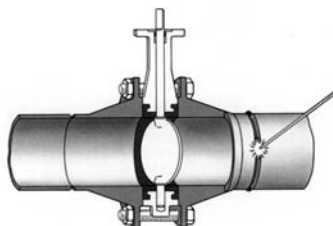

2. Tack weld the flanges to the pipes.

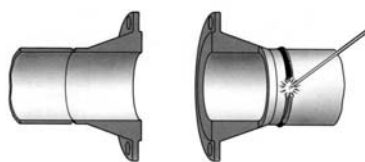

3. Remove the valve and finish weld. Install the valve according to the procedure in the left column.

Installation in a new system

It is common practice to use the valve to help in alignment of the flanges prior to welding the flanges into the pipeline. In such cases, the following instruction applies:

1. Open the valve until the disc is free of the seat but still contained within the face to face of the valve.
2. Align both mating flanges with the valve center line and secure in position using the flange bolts.
3. Position the flange/valve/flange assembly in the pipeline.
4. Tack weld the flanges to the pipeline.
5. Remove the flange bolts and the valve.
6. Finish weld the flanges to the pipeline and allow to cool fully.
7. Follow the procedure for installation in an existing system.

⚠ Warning: Do not finish weld the flanges to the pipeline with the valve still assembled to the flanges as this will result in serious damage to the valve seat.

Maintenance Instructions

Routine maintenance is not normally necessary for the Series 61 valves. If, however, the valve does need to be serviced or repaired for any reason, the following applies.

Removing valve from pipeline

1. Turn the disc to the almost closed position (approximately 5° before closed). The parallel flats or the keyway on the stem are in line with the disc.
2. Loosen all the flange bolts and remove enough bolts to allow the valve to be withdrawn from between the flanges.
3. Spread the flanges using appropriate tooling and carefully remove the valve from between the flanges.

Valve Disassembly

1. Turn the disc to the open position.
2. Remove the screws that fix the two body halves together.
3. Remove the lower body half by inserting flat ended levers into the opposite splits between the body halves and force the body halves apart. Broad bladed flat head screw drivers are acceptable tools.
4. Remove the disc stem and seat from the top body half.
5. Remove the bushing and packing from the neck bore of the top body half.
6. Remove upper and lower bearings.
7. Deform the seat into a long oval, which is sufficient to release the bottom (short) end of the shaft from the seat hole.
8. Pull the long end of the stem from the other seat hole using a twisting action if required.

Valve Assembly

1. Clean all components and replace any damaged components.
2. Insert the long end of the stem into one of the transverse seat holes using a twisting action. If possible, a smear of silicone grease on the shaft will ease this operation.
3. Deform the seat into a long oval sufficient to clear the short end of the shaft and push the short end of the stem into the remaining transverse seat hole.
4. Fit the upper and lower bearings through the body bore. Use a rubber hammer when necessary.
5. Fit the long end of the disc stem into the top half of the body and ensure that the seat is properly located in the dovetail recess of the body half.
6. Insert the bushing and packing into the top end of the body neck bore.
7. Fit the bottom body half over the short end of the disc stem and to the top body half, ensuring that the seat is properly located in the dovetail recess of the body half, and that the small rectangular bosses on each body half are aligned to each other.
8. Secure the top and bottom body halves together using the two hexagon socket cap screws, which should be tightened to the recommended torque.

Keystone Series 61 Butterfly Valve

Installation and Maintenance Instructions

Recommended tightening torques for body screws

Valve size DN	S61W		S61L	
	Bolt size	Tightening Torque Foot lbs.	Bolt Size	Tightening Torque Foot lbs.
2	M8	4	M16	30
2½	M8	4	M16	30
3	M8	4	M16	30
4	M10	7	M16	30
5	M10	7	M16	30
6	M12	12	M20	60
8	M12	12	M20	60
10	M16	30	M24	102
12	M16	30	M24	102

Operation

1. Series 61 valves are opened and closed by turning the top of the stem through 90° using a lever or a gearbox or a quarter turn actuator.
2. Conventionally, the stem is turned 90° counter clockwise to open the valve and 90° clockwise to close the valve.
3. The valve position is indicated by the orientation of the flats or key on the top of the valve stem. If the flats or the centerline of the key are transverse to the pipeline axis, then the valve is closed. If the flats or the centerline of the key are in line with the pipeline axis, then the valve is open.
4. When actuators or gearbox are used to operate the valve, the operating instructions of the actuator or gearbox must be complied with.

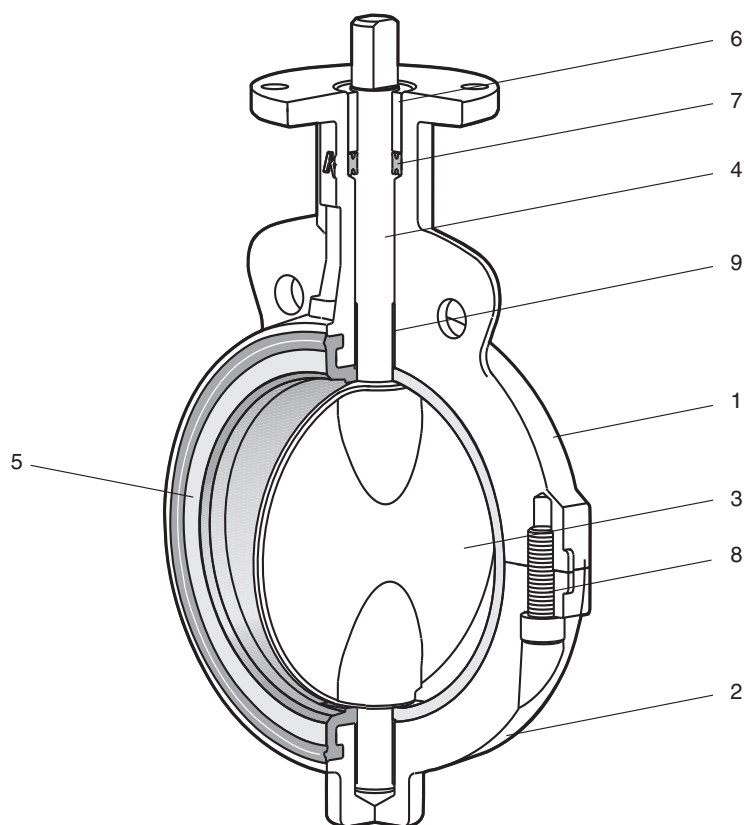

Parts list

No.	Description
1	Upper Body
2	Lower Body
3	Disc
4	Shaft
5	Seat
6	Shaft Bush
7	Shaft Seal
8	Body Screws
9	Bearings

Troubleshooting

Symptom	Probable Cause	Solution
Valve opens only a few degrees and stops (it will not open to the full angle desired).	Improper installation. The valve is improperly aligned.	Loosen the flange bolts, re-align the valve with flanges, and re-tighten the flange bolts to correct torque per ANSI requirements.
Leakage past the flange face.	1. Flange bolts are not evenly torqued.	1. Loosen the flange bolts and tighten the flange bolts to the correct torque per ANSI requirements.
	2. Improper flanges.	2. Refer to "Flange and pipeline compatibility" on page 1.
Leakage in the closed position (leakage in the pipeline).	The disc is not closing fully: 1. Actuator is not properly adjusted.	1. Refer to actuator adjustment procedures.
	2. Line pressure exceeds the valve's working pressure.	2. Reduce line pressure to the valve's working pressure.
Excessively high torque.	1. Obstruction in the pipeline.	1. Remove valve from pipeline and remove obstruction.
	2. Scale build-up on stem or seat.	3. Open and close the valve several times. Operate the valve at least once a month. Check the valve seat for deterioration.

www.tycoflowcontrol.com

www.keystonevalves.com

Tyco Flow Control (TFC) provides the information herein in good faith but makes no representation as to its comprehensiveness or accuracy. This IOM is intended only as a guide to TFC products and services. Individuals using this IOM must exercise their independent judgment in evaluating product selection and determining product appropriateness for their particular purpose and system requirements. TFC MAKES NO REPRESENTATIONS OR WARRANTIES, EITHER EXPRESS OR IMPLIED, INCLUDING WITHOUT LIMITATION ANY WARRANTIES OF MERCHANTABILITY OR FITNESS FOR A PARTICULAR PURPOSE WITH RESPECT TO THE INFORMATION SET FORTH HEREIN OR THE PRODUCT(S) TO WHICH THE INFORMATION REFERS. ACCORDINGLY, TFC WILL NOT BE RESPONSIBLE FOR DAMAGES (OF ANY KIND OR NATURE, INCLUDING INCIDENTAL, INDIRECT, OR CONSEQUENTIAL DAMAGES) RESULTING FROM THE USE OF OR RELIANCE UPON THIS INFORMATION. Patents and Patents Pending in the U.S. and foreign countries. Tyco reserves the right to change product designs and specifications without notice.