

CROSBY



ANDERSON GREENWOOD CROSBY, STAFFORD, TX			
V NB		SIZE STYLE 2 1/2 K2 6 HCI & 3W	
SHOP NO. 82216000	SET PRESS. 600 PSIG	CDTP PSI N/A	
SER. NO. VA0035053	BP PSI N/A	TC PSI N/A	
CAR. 22458 PPH SAT STM	OVER PRESS. 3%		
TAG PSV-503			

Crosby Style HCI Nameplate
(With sample information for illustrative purposes only.)

Before installation these instructions must be fully read and understood.

(For valves purchased prior to January 1, 1998 see IS-V3143)

Table of contents

Ordering Spare Parts	1	Testing	9
Safety Precautions	1	Valve Maintenance	11
Crosby Style HCI-ISOFLEX - Parts	2	General Information	11
Introduction	3	Disassembly	11
Description of Safety Valve	3	Repair Procedure	13
Storage	3	Valve Assembly	15
Installation	4	Spare Parts	18
Hydrostatic Testing	5	Field service requirements	18
Operation	8	Crosby Maintenance Equipment	19

Ordering Spare Parts

When ordering spare parts, the valve size, style and shop number and/or serial number should be given together with set pressure, part name and reference number from page 2. The valve assembly number is shown on the valve nameplate as, "Shop Number." Spare parts may be ordered from any Tyco Valves & Controls Regional Sales Office or Representative.

Safety Precautions

Proper handling, storage, installation, maintenance and operation is essential to the safe and reliable functioning of any pressure relief product.

Precautionary statements in the form of warnings, cautions and notes are used throughout this instruction to emphasize important and critical factors where applicable.

Examples:
WARNING

An operating procedure or practice which, if not strictly observed, may result in injury to personnel or loss of life.

CAUTION

An operating procedure or practice which, if not strictly observed, may result in damage to or destruction of equipment.

NOTE

An operating procedure or condition which is highlighted, underlined or printed in bold type for emphasis.

These precautionary statements are by no means exhaustive. Tyco Valves & Controls cannot be expected to know, evaluate, and advise customers of all conceivable ways in which tasks might be performed, or of the possible hazardous consequences of each way.

Consequently, Tyco Valves & Controls has not included such comprehensive evaluation, and disclaims liability for work performed by other than TV&C personnel.

All personnel working with TV&C products should be adequately trained and thoroughly familiar with the contents of this manual.

Tyco Valves & Controls cannot evaluate all conditions that might injure personnel or damage equipment. However, TV&C does offer the following general safety precautions:

- Hearing and eye protection should be used when working on a valve which is under pressure.
- Never strike a valve which is under pressure. Premature actuation can result.
- Never stand in front of the discharge outlet of a pressure relief valve which is under pressure.
- Always approach and use any pressure relief valve with great care.



Total Flow Control Solutions™

Crosby Style HCI ISOFLEX Safety Valves

Installation, Maintenance and Adjustment Instructions

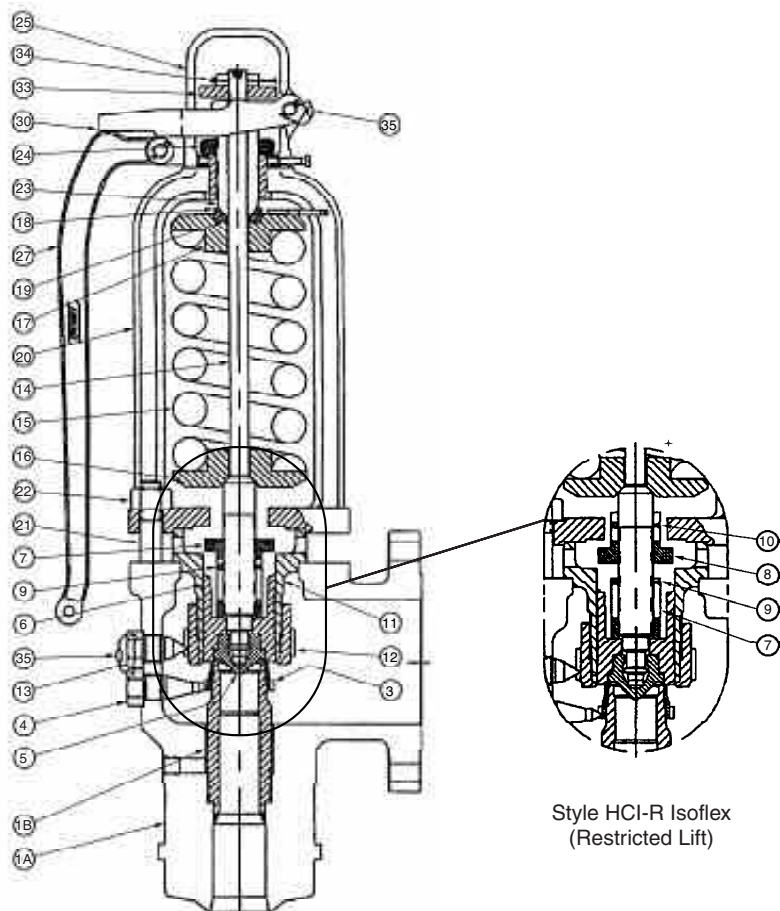

Figure 1

Parts List

Part No.	Part Name	Spare parts designation (See notes 1, 2, 3)
1A	Body	
1B*	Nozzle (semi)	
2*	Nozzle (full)	3
3	Nozzle Ring	3
4	Nozzle Ring Set Screw	
5	Disc Insert	1
6	Disc Holder	2
7	Disc Holder Retainer	
8**	Lift Stop	
9	Disc Holder Retainer Cotter	1
10**	Lift Stop Cotter	1
11	Guide	3
12	Guide Ring	3
13	Guide Ring Set Screw	
14	Spindle Assembly	3
15	Spring	3
16	Bottom Spring Washer	3
17	Top Spring Washer	3
18	Bearing Adapter	
19	Thrust Washer	
20	Bonnet	
21	Bonnet Studs	
22	Bonnet Stud Nuts	
23	Adjusting Bolt	
24	Adjusting Bolt Nut	
25	Cap Assembly	
27	Lever Assembly	
30	Forked Lever Assembly	
33	Spindle Nut	
34	Spindle Nut Cotter	1
35	Seal & Wire	

Notes

1. Consumable Spare Parts: Valve parts which should be replaced as part of any disassembly, and discs and disc inserts which must be replaced if seats are damaged.
2. Repair Spare Parts: Valve parts exposed to wear and/or corrosion during normal operation. They are in fluid flow paths and may require replacement as part of any repair.
3. Insurance Spare Parts: Valve parts exposed to process or environmental wear and/or corrosion and may require replacement as part of a major repair.

Crosby recommends that sufficient inventory of spare parts be maintained to support process requirements. Always be sure to use genuine Crosby parts to ensure continued product performance and warranty.

Notes

- * Semi-nozzle design for welded and R & RR orifice flanged valves.
- ** Restricted Lift Valve (HCI-R) parts only.

Introduction

Crosby Style HCI ISOFLEX safety valves have been selected because of their performance features, reliability and ease of maintenance.

This manual contains sections on installation, hydrostatic testing, field testing and adjustments, and maintenance. Adherence to the installation and maintenance procedures specified in this manual will provide the utmost in safety, a minimum of maintenance and a long service life.

Whenever Style HCI safety valve piece names are used in this manual, piece numbers in parenthesis follow.

The piece numbers are an aid to identifying the pieces in Figure 1 and the correlating parts list on page 2.

As an extension to the HCI product line, Style HCI-R is offered for restricted lift operation. The addition of the "R" in the style designation indicates a restricted lift valve.

Under ASME Code Cases 1923-3 (for Section I service) and 1945-3 (for Section VIII service), restricted lift is offered to allow for more economical valve selection. In accordance with each Code Case the restricted valve capacity is obtained by the use of a lift-restraining device (lift stop). Restricted lift certification is available to as low as 30% of the full rated lift. Figure 2 details the restricted lift construction.

Special tools are not necessary for the maintenance of the Style HCI safety valve. However, tools and equipment are available to ease disassembly and testing of the valves. Such tools and equipment include the Hydraulic Set Pressure Device, the Air Set Pressure Device and the Hydraulic Jacking Device (see page 17). Detailed instructions on their use can be found in Crosby Instructions I-11288, T-1652 and I-1167 respectively.

Description of Safety Valve

The Crosby Style HCI safety valve is shown in Figure 1. Welded inlets and flanged outlets are standard connections. Flanged inlets with full (removable) nozzles are optional. Full (removable) nozzles are not available in flanged "R" and "RR" sizes.

Figure 1 shows the safety valve assembled in cross section, and covers the essential elements of the valve. Approved drawings supplied with the safety valves should be used when installation-specific information is required.

Inside the body (1A) is housed the upper portion of the nozzle (1B or 2), nozzle ring (3), and the guide ring (12). The disc insert (5) is held in place in the disc holder (6) by the spindle assembly (14) and disc holder retainer (7). The disc holder retainer, which also acts as a steam deflector, is threaded to the spindle and held in place by the disc holder retainer cotter pin (9). The nozzle ring and guide ring are held in place by the nozzle ring set screw (4) and the guide ring set screw (13), which are threaded into the body.

The guide (11) is retained between the body (1A) and the bonnet (20) by the bonnet studs (21) and the bonnet studs nuts (22). The guide also incorporates cooling ports between the body and bonnet, which together with the disc holder retainer (7), acts to deflect steam from the spring area.

The bonnet (20) contains the spring (15), spindle assembly (14), bottom spring washer (16) and top spring washer assembly (17). For higher pressure and larger styles, a thrust washer (19) is retained between the top spring washer and the bearing adapter (18). The spindle point is held in compression between the back face of the disc insert (5) and the bottom spring washer. The spring is compressed between the stationary point of contact with the spindle and the adjusting bolt (23) atop the valve bonnet.

The adjusting bolt (23) is locked in place by the adjusting bolt nut (24) on top of the bonnet and within the cap assembly. A means of manual lifting is provided by the lever assembly (27), forked lever assembly (30) and the spindle nut (33).

Storage

Safety valves are often on the job site months before they are installed. Unless they are properly stored and protected, their performance may be seriously affected. Rough handling may damage flanges or cause misalignment of the parts. It is best to leave the safety valves in their shipment cases and store them in a dry place under cover until they are to be installed.

Factory Preparation of Welded Inlet Valves for Shipment

All Crosby Style HCI welded inlet safety valves are equipped with hydrostatic test plugs and shipped in two parts - valve body, and valve superstructure. This makes handling easier for installation welding. (See Figure 2.)

The welded inlet Style HCI safety valves are specially prepared for shipment from the Factory.

After the safety valve is tested as a complete assembly for set pressure and tightness, the spring set compression is held by spacer blocks under the bottom spring washer (16) as illustrated in Figure 2.

The safety valve superstructure is then removed from the valve body. The two portions are boxed and shipped separately. Each portion, ready for shipment, is illustrated in Figure 2.

Figure 2 shows the safety valve body as shipped to the installation site. It is tagged as follows:

Install and/or weld in place as required. Prepare for hydrostatic test - See instruction. Hydrostatic plug in place. Install O-ring and backup ring prior to hydrostatic test.

Figure 2 shows the safety valve superstructure as shipped to the installation site. It is boxed separately from the valve body and is tagged as follows:

Hold for assembly after hydrostatic test.

Note 1 to Figure 2

Delivered with the body and packaged in small bag are the following:

- One O-ring (for hydrostatic test)
- One backup ring (for hydrostatic test)
- One hydrostatic test plug pin

Note 2 to Figure 2

Delivered with the superstructure and packaged in a small box are the following:

- Valve nozzle ring *
 - Valve nozzle ring set screw *
 - Valve guide ring set screw *
 - Seal wires
- * Marked with valve identification number.

Note: When the above parts are removed from their box, be sure that the identification of parts to valve number is maintained and that the parts are stored to facilitate later recovery for assembly.

Installation

Inlet Piping Many safety valves are damaged when first placed in service because of failure to clean the connections properly before installation. The safety valve inlet, the vessel and the line on which the safety valve is mounted must be thoroughly cleaned of all foreign matter. Safety valves should be mounted in a vertical position, directly on the pressure vessel. The ASME Boiler and Pressure Vessel Code limits the distance between the safety valve inlet and the boiler to the length of a standard tee fitting. The nozzle should have a well-rounded approach that provides smooth, unobstructed flow between the vessel and the safety valve. A safety valve should never be installed on a fitting having an inside diameter smaller than the inlet connection of the valve. Such restriction of flow can cause faulty valve operation.

Inlet piping (nozzles) must be designed to withstand the total resultant forces due to the safety valve discharging at the maximum accumulated pressure and the expected piping loads. The precise nature of the loading and the resulting stresses will depend on the configuration of the safety valve and the discharge piping. Determination of outlet reaction forces is the responsibility of the designer of the vessel and/or piping.

Outlet Piping Discharge piping should be simple and direct. Back pressures built up by discharge flow affect the operation of safety valves. Where possible, a short vertical pipe connected through a long radius elbow discharging directly into the atmosphere is the most desirable type of outlet piping.

Discharge piping should not impose any loading on the safety valve. Excessive discharge piping loads may cause seat leakage or faulty valve operation. The inside diameter of the discharge pipe must never be less than that of the safety valve outlet.

Valve effluent must discharge to a safe disposal area.

The safety valve bodies have pipe thread openings for drains. These should be connected to prevent any accumulation of fluid in the valve body. In addition, discharge piping should also be drained to prevent any accumulation of fluid. Care must be taken to ensure that the drains are directed or piped to a safe disposal area.

Welding of Welded Inlet Valve Body to Boiler Welded inlet safety valve bodies should be welded to the boiler in accordance with applicable Code requirements. The protective cover should be left in place until ready for the hydrostatic test of the unit. If visual inspection is necessary, the protective cover may be removed, but should be replaced.



Top View - Body



Hydro Components

(See Note 1)

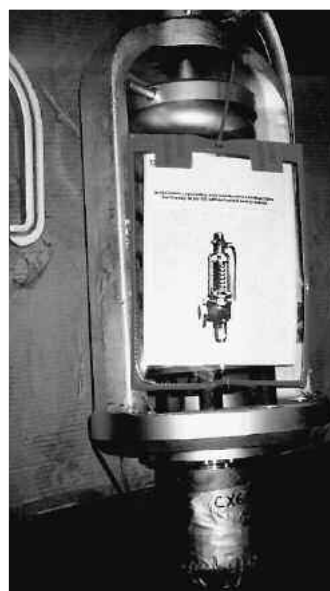

(See Note 2)

Figure 2
Valve Superstructure as Shipped

Hydrostatic Testing

General information Depending on the type of inlet, hydrostatic testing of safety valves may be carried out by one of three means: blank flanges, test plugs or test gags. In all cases, hydrostatic test pressure must be limited to 1 1/2 times the nameplate set pressure of the valve. Additionally, hydrostatic test pressure must be limited to 10% above the nameplate set pressure when a test gag is used.

Welded inlet safety valves All Style HCI welded inlet safety valves are prepared for shipment from the factory with hydrostatic test plugs.

Hydrostatic tests of these valves shall be conducted using hydrostatic test plugs as detailed in paragraph below, "Hydrostatic Testing Using Hydrostatic Test Plugs."

Flanged inlet safety valves Flanged inlet safety valves should not be installed for hydrostatic testing. Blank flanges should be used instead of gagging the safety valves. This prevents possible damage to the safety valves due to excessive tightening of the gag screws or leakage during hydrostatic test which may result in costly repairs. Blank flanges must be removed and the safety valve reinstalled before the vessel is placed in service.

If blank flanges are not used and the safety valves are to be installed for hydrostatic tests, Crosby recommends that hydrostatic test plugs be used for hydrostatic test. The detailed procedure is outlined in the paragraph following.

Hydrostatic test plugs for flanged valves are optional equipment and are provided only when ordered.

Hydrostatic testing using hydrostatic test plugs Before imposing the hydrostatic test pressure on the vessel or system, perform the following operations:



CAUTION

Before hydrostatic testing, the O-ring and backup ring must be installed.

- Preparation for hydrostatic testing - welded inlet safety valves
The O-ring, backup ring and the test plug pin are shipped in a bag within the body. To install the O-ring and backup ring refer to Figure 2.
Remove the protective cover from the valve body. Unscrew the cap from the nozzle. Remove the test plug from the nozzle bore.
- Preparation for hydrostatic testing - flanged inlet safety valves
Flanged inlet safety valves are shipped from the Factory fully assembled. To use the hydrostatic test plug, the valve must be disassembled per paragraph on page 11, "Disassembly Retaining Spring Compression."
- Installation of hydrostatic test plug (see figure 2)
- Inspect the hydrostatic test plug O-ring groove.
NOTE: Make sure the groove in the plug is clean.
- Install the O-ring and backup ring in the test plug groove. Replace the test plug in the nozzle bore.



CAUTION

Make sure the cap has hand-tight contact with the plug. Make sure there is enough thread engagement of the cap onto the nozzle.

- Place the test plug cap over the plug and screw it down hand-tight.



CAUTION

Be sure the test plug is seated on the 45° angle on the nozzle inside diameter.

- Install the test plug pin.
- The valve is now ready for hydrostatic test.
- Hydrostatic test

After the above preparation, the safety valve is ready for hydrostatic test. Observations should be made at the start of the test to confirm that the O-rings have been properly installed and there is no leakage when pressure is applied.



CAUTION

Tightening of the cap will not reduce leakage. If leakage is evident, remove all pressure from the vessel or system. Replace the O-ring and the backup ring.

Crosby Style HCI ISOFLEX Safety Valves

Installation, Maintenance and Adjustment Instructions

• Assembly of Valve

After completion of the hydrostatic test, remove the hydrostatic test plug from the nozzle.

To aid removal, place the hydrostatic test plug pin in the hole in the plug extension. Unscrew the cap, which will engage the plug pin and exert an upward force as the cap is turned, thus lifting the plug and rings from the valve nozzle.

Clean the nozzle bore and seat and inspect the seating surface. If seating surfaces are damaged, repair according to the directions in paragraph on page 13, "Repair Procedure".

Assemble the valves according to the instructions in paragraph on page 7, "Initial Safety Valve Assembly."

Hydrostatic Test Using Gag The Crosby safety valve test gag shown in Figure 3 can be used with both welded and flanged inlets, but at pressures no greater than 10% above the nameplate set pressure. Gagging should be very carefully done in order not to overload the valve spindle or cause damage to the valve seats.

The following outlines the recommended procedure for gagging valves for hydrostatic test:

- Remove the lever (27), forked lever (30), cap (25) and spindle nut (33).
- Refer to Figure 3. Lubricate the threads and pointed end of the gag screw. Install the gag in place, being careful that the legs fit uniformly. Contacts on both legs of the gag should seat evenly on the underside of the bonnet top.
- Tighten the gag finger-tight only at this point.
- Raise the system pressure to approximately 100 psig below the nameplate set pressure of the safety valve.
- Apply the necessary torque to the gag in accordance with the value shown in Table 1 for the orifice size. This torque value is determined as follows:
 - Determine ΔP by subtracting the valve set pressure from the hydrostatic test pressure.
 - Read the value of ΔP on the vertical scale. Proceed horizontally to the appropriate orifice size and then down to read the torque on the horizontal scale.
 - The torque values (foot-pounds) obtained should be increased by a factor of approximately 25% to account for normal variations in friction, safety valves and test conditions.
- After applying the necessary torque to the gags, increase the hydrostatic test pressure to the required amount. Observations should be made during the rising pressure cycle to determine if any of the safety valves show seat leakage.



CAUTION

Should any safety valve show seat leakage, the pressure must be lowered until the leakage stops.

Table 1 - Normal Gagging Load in ft-lb. of Torque (N-m) vs. ΔP (Overpressure Less Valve Set Pressure)

ΔP (Overpressure) Less Valve Set Pressure	Orifice								
	H 2	J 2	K 2	L 2	M 2	P 2	Q 2	R	RR
50 psi (3.45 bar)	1 (1.4)	1 (1.4)	1 (1.4)	2 (2.7)	2 (2.7)	4 (5.4)	7 (9.5)	9 (12.2)	10 (13.6)
100 psi (6.89 bar)	1 (1.4)	2 (2.7)	3 (4.1)	4 (5.4)	4 (5.4)	8 (10.8)	13 (17.6)	17 (23.1)	20 (27.1)
150 psi (10.34 bar)	2 (2.7)	2 (2.7)	4 (5.4)	5 (6.8)	6 (8.1)	11 (14.9)	20 (27.1)	25 (33.9)	30 (40.7)
200 psi (13.79 bar)	2 (2.7)	3 (4.1)	5 (6.8)	7 (9.5)	8 (10.8)	15 (20.3)	25 (33.9)	33 (44.7)	40 (54.2)
250 psi (17.24 bar)	3 (4.1)	4 (5.4)	6 (8.1)	9 (12.2)	10 (13.6)	18 (24.4)	32 (43.4)	41 (55.6)	49 (66.4)
300 psi (20.68 bar)	3 (4.1)	5 (6.8)	7 (9.5)	11 (14.9)	12 (16.3)	22 (29.8)	38 (51.5)	49 (66.4)	50 (67.8)

- The torque should then be increased on the gag about 10% above the initial torque value.



CAUTION

Never increase the gagging load while a safety valve shows seat leakage. This can result in damage to the valve seats and bending of the spindle.



WARNING

Do not try to assemble the valve or remove the steel blocks from under the bottom spring washer without use of proper servicing and assembly equipment.



CAUTION

Gags should not be used when inlet pressures are more than 10% greater than the safety valve set pressure. Damage to the valve may result.

Figure 3 - Valve Gag

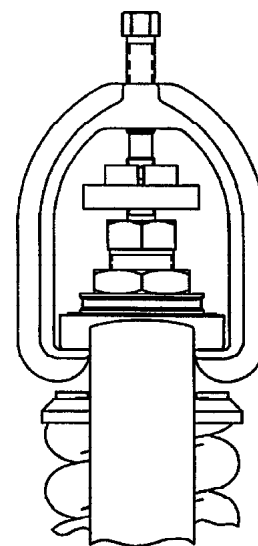

Position gag evenly on bonnet

- After the hydrostatic test, the pressure on the system should be dropped to approximately 100 psi below the nameplate set pressure of the safety valve. The gags should be loosened at this point and removed from the valves.
- After the hydrostatic test, the gag should be removed and the cap installed per paragraph on page 18, "Assembly of Cap."



CAUTION

Valve gags should not be left on the valves in a gagged or loaded position for an extended period or under conditions where large thermal variations are expected.

Initial Safety Valve Assembly After hydrostatic testing using hydrostatic test plugs, the safety valves should be assembled.

NOTE It is recommended that, on completion of all hydrostatic tests using hydrostatic test plugs on new installations, a Crosby service technician be present for assembly of the safety valves.

Check the valve identification numbers and match the proper valve superstructure to each valve body.

The nozzle ring (3) and the set screws (4 and 13) are packaged together and shipped with the superstructure as shown in Figure 2.



CAUTION

Each valve superstructure, nozzle ring and set screw is identified and matched to a specific valve body by a tag number and should be assembled accordingly. Although all parts have been thoroughly cleaned, inspected, lubricated and protected for shipment, the parts should be inspected before installation for evidence of foreign matter or damage. Special attention should be given to the seating surfaces of the disc and nozzle. These seats should be free from surface damage. If cleaning or repair is necessary refer to paragraph on page 13, "Repair Procedure."

Initial Assembly

- Remove the body protective cover (see Figure 2). Take the nozzle ring (3), nozzle ring set screw (4), and guide ring set screw (13) from their package. Match the set screws to the body (1A) and bonnet (20) valve identification markings.
- Screw the nozzle ring (3) onto the nozzle (1B or 2).
Note: The top of the nozzle ring (3) should be about one ring revolution above the nozzle (2) seating surface.
- Remove the guide (11) and guide ring (12) from the superstructure. The guide ring should be screwed onto the guide. Install the guide and guide ring assembly into the top of the body (1A). Make sure the guide is seated correctly in the body. Make sure that the nozzle (1A or 2) and disc insert (5) seats are clean and undamaged. If cleaning or repair is necessary refer to paragraph on page 13, "Repair Procedure."
- Remove the lever (27), forked lever (30) and cap (25) from the valve superstructure. Do not remove the spindle nut (33).
- Using a suitable lifting device, lift the valve superstructure with the spindle (14) vertical. Inspect and clean the guide to- bonnet fit and the body-to-guide fit. Position the superstructure so the valve identification number stamped on the bonnet (20) is opposite the valve outlet.
- Lowering the valve superstructure slowly, carefully lower the disc holder (6) into the guide (11).



CAUTION

Do not permit any rocking motion of the spindle (14), or any other part while lowering the superstructure into the body (1A). Any rocking motion could damage the valve seats.

- After the superstructure is in place, inspect to be sure the bonnet (20) is fully seated on the guide (11).
- The nozzle ring (3) should now be lowered. Lift the disc insert (5) slightly off the seat by lifting the spindle (14).
- Place a screwdriver in the lower set screw hole. Turn the nozzle ring (3) to the left (clockwise) with the screwdriver until the top edge of the nozzle ring is below the nozzle (1B or 2) seating surface. The location can be checked by looking in through the upper set screw hole while shining a light through the lower set screw hole. Lower the spindle (14) assembly slowly until it bottoms. Check that the nozzle ring (3) moves freely. Rotate the spindle clockwise several revolutions to make sure that it is fully seated on the disc insert and that the threads of the spindle are not engaged.
- The seating surfaces are now in full contact.

Table 2 - Tightening of Bonnet and/or Cooling Spool Stud Nuts

Stud Thread	Torque (ft/lb) (N-m) to Produce Stress in Stud Bolts		
	30,000 psi (2,068 bar) Stress	45,000 psi (3,203 bar) Stress	60,000 psi (4,137 bar) Stress
5/8 - 11	60 ft/lb (81 N-m)	90 ft/lb (122 N-m)	120 ft/lb (163 N-m)
3/4 - 10	100 ft/lb (136 N-m)	150 ft/lb (203 N-m)	200 ft/lb (271 N-m)
7/8 - 9	160 ft/lb (217 N-m)	240 ft/lb (325 N-m)	320 ft/lb (434 N-m)
1 - 8	240 ft/lb (325 N-m)	370 ft/lb (502 N-m)	500 ft/lb (678 N-m)
1-1/8 - 8	350 ft/lb (475 N-m)	525 ft/lb (712 N-m)	700 ft/lb (949 N-m)

- Install the bonnet stud nuts (22) on the bonnet studs (21) and tighten uniformly in accordance with Figure 4:

1. Valve studs and nuts shall be clean and visually inspected to ensure freedom from any objectional foreign matter, rust, burrs, or physical damage.
2. With the bonnet in place, lubricate the bonnet studs threads, the nut threads and nut face with Never-Seez compound (which conforms to Government Specification MIL-A-907B, Federal Stock Number 803-286-5453) or equivalent.
3. Install nuts on the studs, finger-tight.
4. Referring to Figure 4, tighten the nuts in the sequence shown in the diagram to approximately one half the torque value shown in Table 2. Repeat the same sequence of tightening to the torque value shown. Then, starting with the Number 1 nut, tighten each nut in order in a clockwise or counterclockwise direction to the value shown in Table 2.
5. Wipe off excess lubricant.

- It is now necessary to remove the spacer blocks under the bottom spring washer (16), thereby transferring the spring load to the valve seats. This should be done using the hydraulic jacking device (see Figure 13 on page 17). Refer to Crosby Instruction I-1167 for detailed instructions in the use of this device.

After the spacer blocks have been removed, set the nozzle ring (3) and guide ring (12) according to the paragraph on page 18, "Setting of Rings."

- Lock the nozzle ring set screw (4) and the guide ring set screw (13) in place, making sure that the proper set screws are installed and fully engaged in a notch. Lock wire them in place and seal.
- Complete the valve assembly with the cap assembly as described in paragraph on page 18, "Assembly of Cap", and seal wire the cap.

Operation

The Crosby Style HCI safety valve opens with a sharp pop at the set pressure and remains open, relieving rated capacity at 3% overpressure. As inlet pressure decays below the opening pressure, the safety valve remains open until a pressure about 4% below the set pressure is reached. At that point the safety valve closes sharply.

The sharp opening is produced in two stages. The initial lift is produced when the steam pressure under the disc insert (5) exceeds the spring pressure. To aid in starting the popping action, steam escapes between the safety valve seats and is deflected by an angle on the nozzle ring (3) as shown in Figure 5. This escaping steam acts on the face of the disc holder (6) causing an unbalance and the safety valve pops open. As the disc holder lifts vertically, steam begins to react against the guide ring (12) and to push the disc holder up to a high lift as shown in Figure 6. The reaction of the deflected steam pushes against the underside of the disc holder and lifts it still higher on an accumulation of pressure. As the boiler pressure drops, the safety valve disc insert (5) settles to a moderate lift and closes sharply.

The nozzle ring (3) is primarily for ensuring sharp opening action. Raising the nozzle ring, bringing it closer to the face of the disc holder (6), eliminates "simmer" or "warn."

The guide ring (12) is primarily for controlling blowdown. Raising the guide ring reduces the reactive pressures against the disc holder and reduces blowdown. Lowering the guide ring increases the reactive pressures against the disc holder and increases the blowdown.

Figure 4 Tightening of Bonnet Stud Nuts

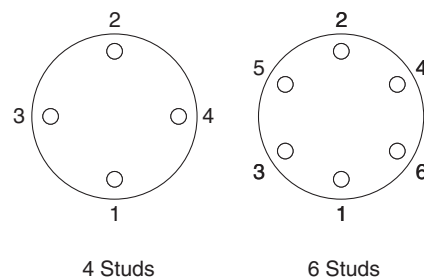

Figure 5 Effect of Nozzle Ring

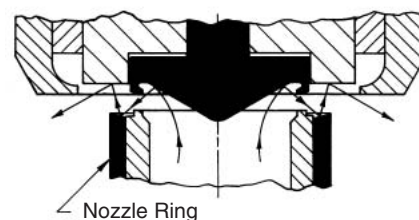
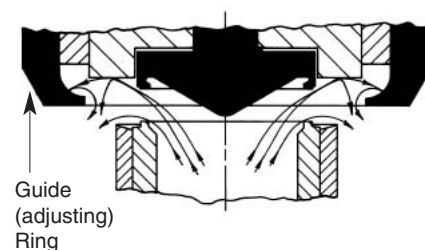

Figure 6 Effect of Guide Ring



Testing

Set Pressure Testing and Valve Adjustments The set pressure of a safety valve may be checked without removing the valve from the system by two methods described in the following paragraphs:

- **Set Pressure Lift Assist Device**

The first method of set pressure testing is with the use of a set pressure lift device. This allows set pressure testing of the safety valves on the system at pressures below normal system operating pressures.

Two devices are available for use on the Crosby Style HCI safety valve - the Air Set Pressure Device and the Hydraulic Set Pressure Device. Refer to Crosby Test Procedure T-1652 for detailed instructions in the use of the Air Set Pressure Device, and Crosby Instruction I-11288 for detailed instructions in the use of the Hydraulic Set Pressure Device.

- **System Pressure**

The second method of set pressure testing is by raising the system pressure and popping the safety valve. Set pressure testing using this method will determine the safety valve set and closing pressure (blowdown).



WARNING

Never strike a valve which is under pressure. Premature actuation can result.

Setting the safety valve with the Set Pressure Lift Device is recommended before raising the system pressure for popping pressure testing. This allows the set point to be established without raising and lowering system pressure several times to determine the safety valve set pressure.

Before set pressure testing and raising the system pressure, the following items should be checked:

- A pressure gage with known accuracy should be located on the system being tested.
- Outlet piping should be anchored sufficiently to prevent any vibrations while the safety valve is discharging. The outlet piping should be direct and there should be no obstructions to restrict the safety valve discharging.
- Set screws should be tight and lock wired. The tapped holes in the body for drains should be connected to the drain, or plugged.
- Lifting gear should be securely fastened to the safety valve to assist personnel testing the valve. A rope may be attached through the hole provided in the lever should mechanical lifting be necessary.
- Communications should be set up between the control room and personnel in the test area.



WARNING

Hearing and eye protection should be used when working on a valve which is under pressure. Never stand in front of the discharge of a safety valve which is under pressure.



CAUTION

All safety valves on the system except the valve that is to be popped should be gagged. System pressure should be 70% of valve set pressure before gagging to prevent added loads from being applied to the valve spindle due to thermal expansion. Gagging must be done with care not to overload the spindle since considerable damage may occur to the spindle and other valve internals. However, a minimum torque should be applied to the gag by hand to ensure that the valve will not open.

- Install the gags as follows: Refer to Figure 3 on page 6.
 - Remove the lever (27), forked lever (30), cap (25) and spindle nut (33).
 - Lubricate the threads and pointed end of the gag screw.
 - Install the gag in place, being careful that the legs fit uniformly. Contacts on both legs of the gag should seat evenly on the underside of the bonnet top.
 - Tighten the gag finger-tight.
- Raise the system pressure until the safety valve pops.
- Record the popping and reseating pressures (pressure at which the safety valve closes sharply).

• Set Pressure Adjustment

If the safety valve pops before the nameplate set pressure is reached, or if it does not pop at the nameplate set pressure, the following steps for set pressure adjustment should be taken:



WARNING

Set pressure adjustment should not be made until the system pressure is 10% to 20% below the actual popping pressure of the safety valve. The adjusting bolt should never be turned when the vessel pressure is near the set pressure of the safety valve.

- Remove the lever (27), forked lever (30) and cap (25).
- Loosen the adjusting bolt nut (24).
If the safety valve has popped below the set pressure stamped on the valve nameplate, an increase in set pressure is necessary. This is obtained by turning the adjusting bolt (23) clockwise (compressing the spring). If the safety valve popped above the nameplate set pressure, decrease the set pressure by turning the adjusting bolt counterclockwise (relieving spring compression).
- After each adjustment, the adjusting bolt nut (24) should be securely tightened to prevent loosening of the bolt. The lifting gear should be reinstalled.
- After the safety valve has been adjusted to open at the desired pressures, remove the lifting gear and make sure the adjusting bolt nut (24) is installed properly and tightened. Install the cap assembly (25) per paragraph on page 18, "Assembly of Cap," making sure there is $1/16$ " clearance between the spindle nut (33) and the forked lever (30). Seal wire the cap and set screws (4 and 13).
- The nozzle ring and guide ring settings are determined at the Factory. Their locations are stamped on the valve bonnet (20) where the cap is seated. Adjusting (guide) ring positions are recorded as plus (+) or minus (-) numbers from the level position. An illustration of the guide ring sign convention is presented in Figure 7. However, if the desired blowdown was not obtained, it will be necessary to adjust the rings. The following steps should be taken:



WARNING

Never make ring adjustments with the vessel under pressure without gagging the safety valve properly. Be careful to use only enough torque to hold the valve closed. Overgagging may damage the valve internals.

Nozzle Ring and Guide Ring Adjustment

- The guide ring (12) is the principal blowdown control ring in the safety valve. To change the guide ring position, remove the guide ring set screw (13) from the body (1A). Insert a screwdriver or similar tool and engage one of the notches (these can be seen through the set screw hole.)
- The guide ring can then be turned to the right or left as desired. Moving the guide ring to the right (counterclockwise) raises it and decreases the blowdown. The guide ring should never be moved more than ten notches either way without retesting the valve.
- After each adjustment, always replace, tighten and lock wire the set screw, being careful that its point engages a notch.
- The nozzle ring (3) is necessary for obtaining the pop action of the safety valve. This ring setting is determined at the Factory and rarely needs further adjustment. However, in case the guide ring (12) does not give the desired operating characteristics under all conditions of operation, the nozzle ring may be adjusted to control the valve operation for very fine adjustment. The nozzle ring is adjusted by removing the nozzle ring set screw (4) from the valve body (1A).
- Turning the ring to the right (counterclockwise) raises it and results in a strong pop action. Blowdown will increase. Turning the ring to the left (clockwise) lowers the ring, decreases the blowdown and may result in warn or simmer if lowered too far. The range of adjustment of the nozzle ring is limited and it should not be moved more than one notch at a time.
- The valve performance should be checked after each adjustment. After each adjustment always replace, tighten and lock wire the set screw, being careful that its point engages a notch. Whenever ring adjustments are changed, a record should be kept of the number of notches and the direction in which the ring was moved. This will make it possible to return to the original setting in case of error.
- After the safety valve has been adjusted to close at the desired pressure, remove the lifting gear and make sure the adjusting bolt nut (24) and the set screws (4 and 11) are installed properly and tightened.
- If, after testing, different ring locations are obtained, restamp the top of the valve bonnet (20) with the new (tested) ring settings.
- Install the cap assembly (25) according to paragraph on page 18, "Assembly of Cap," making sure there is $1/16$ " clearance between the spindle nut (33) and forked lever (30). Seal wire the cap and set screws (4 and 13).

Figure 7

Guide Ring Level with Disc Holder

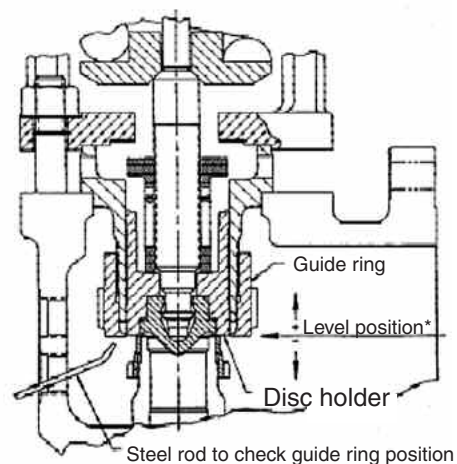

* Factory setting of guide ring position (+/-) notches from level stamped on bonnet

**WARNING**

There should be no system pressure when a safety valve is either dismantled in place or removed for shop repair.

Valve maintenance**General information**

When possible, remove the safety valve from the system before dismantling (flanged inlet).

Nozzle and guide ring set screws are custom fitted to each safety valve and should never be interchanged.

The spring washers are fitted to each end of the spring. The spring and washers must be kept intact as a unit.

Before disassembly, spare parts and service equipment such as lapping compound, lapping blocks, and jacking, gear should be available. **Disassembly**

- Disassembly Retaining Spring Compression

If the safety valve is to be reconditioned without retesting, the original set pressure can be retained by use of a hydraulic jacking device (see Figure 13 on page 17). This device is a service tool that can be obtained from TV&C. (see page 18). Refer to detailed instructions in the use of this device in Crosby Instruction I-1167.

- Remove the lever (27), forked lever (30), cap (25) and spindle nut (33).
- Remove the nozzle ring set screw (4). Check the setting of the nozzle ring (3) by turning it to the right (counterclockwise), counting the number of notches turned until it contacts the disc insert (5) or disc holder (6). Record the number of notches. This location is given as minus (-) notches from this contact position.
- Remove the guide ring set screw (13). The guide ring should be turned to the right (counterclockwise) or left (clockwise) whichever is necessary to return it to its level position. The guide ring is in level position when the bottom face of the guide ring is level with the bottom face of the disc insert or disc holder. This position is illustrated in Figure 7 on page 10. The guide ring position is recorded as minus (-) (down) or plus (+) (up) notches from this level position.
- Measure the distance between the bottom face of the bottom spring washer (16) and the bonnet flange (20) and record the dimension. Cut three pieces of bar stock $\frac{1}{8}$ " longer than the recorded dimension for spacer blocks.
- Install the hydraulic jacking device in accordance with Crosby Instruction I-1167. Apply hydraulic pressure to raise the valve spindle, raising the bottom spring washer and compressing the spring.
- After the spring load has been taken up and the valve has been jacked about $\frac{1}{8}$ ", place the spacer blocks under the bottom spring washer (16). See Figure 2.
- Release the hydraulic pressure to allow the spring load to rest on the spacer blocks.
- If so desired, the jacking device can now be removed in accordance with the instructions for that device.
- Thread the spindle nut (33) on the spindle (14) to hold the spindle in position during disassembly, or leave the jacking device in place. Loosen and remove the bonnet stud nuts (22).
- Using suitable lifting means, carefully lift the superstructure straight up and out of the body.

**CAUTION**

Do not permit any rocking motion of the spindle or any other parts while lifting the superstructure out of the body. Any rocking motion could damage the valve seats.

- Lay the superstructure down with the spindle horizontal. Care must be exercised to prevent the parts from being damaged.
- Remove the spindle nut (33) or jacking device from the spindle (14). Carefully slide the spindle (12) and disc holder (6) as an assembly from the jacked and blocked spring (15) and bonnet (20).
- Proceed with disassembly of the internals according to paragraph on page 12, "Disassembly of Internal Structure."
- Disassembly without retaining spring compression
To disassemble the safety valve completely and not retain the spring compression, the following procedure should be used:
 - Remove the lever (27), forked lever (30), cap (25) and spindle nut (33).
 - Remove the nozzle ring set screw (4). Check the setting of the nozzle ring (3) by turning it to the right (counterclockwise), counting the number of notches turned until it contacts the disc holder (6) (see Figure 7 on page 10). Record the number of notches. This location is given as minus (-) notches from this contact position.
 - Remove the guide ring set screw (13). The guide ring should be turned to the right (counterclockwise) or left (clockwise) whichever is necessary to return it to its level position. The guide ring is in level position when the bottom face of the guide ring is level with the bottom face of the disc holder. The guide ring position is recorded as minus (-) (down) or plus (+) (up) notches from this level position.

- Measure from the top of the adjusting bolt (23) to the machined surface of the bonnet (20) top and record this measurement. This measurement will be used when the valve is reassembled.
- Release spring tension by loosening the adjusting bolt nut (24) and then the adjusting bolt (23).



WARNING

Never loosen the bonnet stud nuts (22) before releasing the spring tension with the adjusting bolt (23).

- After making sure all spring tension has been released, loosen and remove the bonnet stud nuts (22). Strap the spring (15) into the bonnet (20) to prevent the spring from falling out from between the bonnet struts. Using suitable lifting means, carefully lift the spring and bonnet assembly straight up and over the spindle (14).
- Set the assembly aside. Carefully lift the spindle (14) and internals straight up and out of the body (1A).



CAUTION

Do not permit any rocking motion of the spindle or any other parts while lifting the spindle and internals out of the body. Any rocking motion could damage the valve seats.

- Lay the spindle and internals down horizontally.
- Proceed with disassembly of the internals according to paragraph below, "Disassembly of Internal Structure."
- Should lack of overhead space prevent the bonnet (20) being lifted over the spindle, the spindle nut (33) may be installed to hold the spindle in position. Using suitable lifting means, carefully lift the superstructure straight up and out of the body.



CAUTION

Do not permit any rocking motion of the spindle or any other parts while lifting the spindle and internals out of the body. Any rocking motion could damage the valve seats.

- Lay the superstructure down so the spindle is horizontal.
- Care must be exercised to prevent the parts from being damaged.
- Remove the spindle nut (33) from the spindle (14). Carefully remove the spindle and spring (15) and washers (16 and 17) from the bonnet (20).
- Proceed with disassembly of the internals according to the following:

• *Disassembly of Internal Structure*

- Remove the guide (11) and guide ring (12) from the body (1A) as an assembly, and unscrew the guide ring from the guide.
- Remove the spindle (14) from the disc insert (5) by lifting the spindle slightly to engage the threads and unscrewing the spindle from the disc insert.
- Unscrew the nozzle ring (3) from the nozzle (1B or 2). All the parts should be cleaned thoroughly, paying special attention to guiding surfaces. The seats should be lapped according to section following, "Lapping or Refurbishing of Valve Seats."

If replacement parts are required, refer to "Ordering Spare Parts" on page 1.

Note: Whenever the guide (11), disc insert (5), or nozzle (2) are replaced, the lift stop (8) should be removed and reset according to paragraph, "Setting of Lift Stop" on page 15.

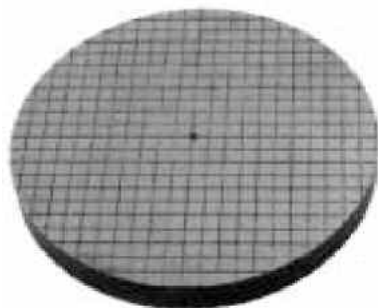
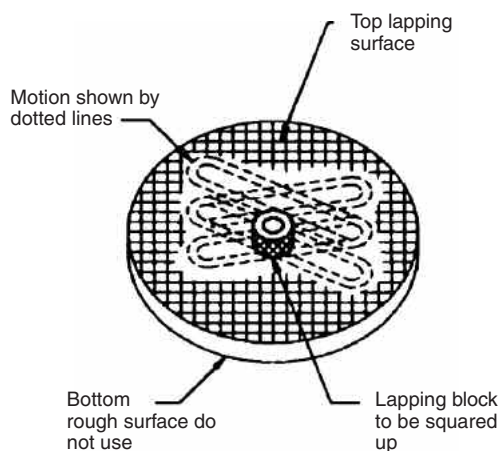

Lapping block resurfacing plate



Lapping block

Figure 9

Repair Procedure

- **Lapping or Refurbishing of Valve Seats**
 Good seating surfaces on the nozzle and disc insert are of the greatest importance when reconditioning safety valves. The seats should be flat and free from surface scratches.
- **Lapping Block**
 This is made of a special grade of annealed cast iron, perfectly flat on both sides. It must remain flat to produce a flat seating surface. In checking the lapping block and for restoring flatness after use, a lapping block resurfacing plate should be used.
- **Lapping Block Resurfacing Plate**
 This is also made of a special grade of annealed cast iron, machined and lapped on the side that has small squares. This is the surface on which lapping blocks are reconditioned.
- **Lapping Compound**
 Experience has proven that three grades of compound -medium, fine and polish - will properly condition almost any damaged valve seat except where the damage requires remachining. A medium coarse compound may be used for fast cutting as a first operation after machining if desired. The following lapping compounds, or their commercial equivalents, are suggested.

Grit Compound Number	Description
320	Medium Coarse
400	Medium
600	Fine
900	Polish

Table 3 - Disc Insert Minimum Seat Heights

Orifice	H ₂	J ₂	K ₂	L ₂	M ₂	P ₂	Q ₂	R	RR
"B" Minimum	.004 in	.004 in	.006 in	.007 in	.007 in	.010 in	.013 in	.015 in	.016 in
Dimension After Lapping	.102 mm	.102 mm	.152 mm	.178 mm	.178 mm	.254 mm	.330 mm	.381 mm	.406 mm

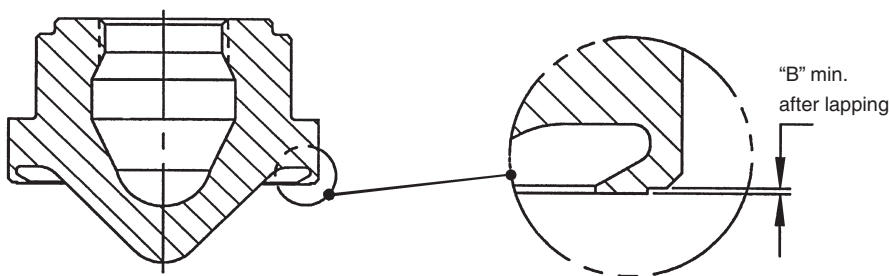

Figure 8

- **Lapping Procedure**
 Different individuals have different methods of lapping valve seats, but certain essential steps must be taken to get satisfactory results. The following procedure is suggested for lapping of valve seats:



CAUTION
 Never lap the disc insert against the nozzle.

- Lap each part separately against a cast iron lapping block of the proper size. These blocks hold the lapping compound in their surface pores, but must be recharged and reconditioned frequently.
- Check the lapping block frequently on a good lapping block resurfacing plate to make certain that it is perfectly flat on both sides.
- If considerable lapping is required, spread a thin coat of medium lapping compound on the block. After lapping with this compound, lap again with fine compound using a new lapping block surface. Unless much lapping is called for, the first step can be omitted. Next, lap again using a polish compound.
- Lap the block against the seat. Never rotate the block continuously, but use an oscillating movement.

- When all the nicks and marks have disappeared, remove all the compound from the block and seat. Apply polish compound to another block and lap the seat with this. As the lapping nears completion only the compound left in the pores of the block should be present. This should give a very smooth finish. If scratches appear, the cause is probably dirty lapping compound. These scratches should be removed by using compound free of foreign material. Be extremely careful to keep the seats flat.

Refurbishment of Disc and Disc Insert Seats

When the damage to the disc insert (5) seat is too severe to be removed by lapping, the disc insert should be replaced. Disc inserts should never be remachined.

Remachining the insert will change critical dimensions, affecting the operation of the safety valve. The disc insert seating surface may be lapped if the minimum seat height shown in Figure 8 on page 13 is maintained.

Refurbishment of Nozzle Seats

If machining of the nozzle (1B or 2), seat or other major repairs are necessary, it is recommended that the valve be returned to a Crosby authorized facility for repair.

All parts must be accurately machined per Crosby specifications. No safety valve will be tight nor will it operate properly unless all parts are correctly machined. If unable to return to a Crosby authorized repair facility for remachining, use of a Crosby reseating machine is recommended (see page 18).

Machining dimensions for Crosby Style HCI safety valves are shown in Figure 11. Remove only enough metal to restore the surface to its original condition.

Turning to the smoothest possible finish will facilitate lapping.

The nozzle must be replaced when the minimum face-to-seat dimension is reached. This critical dimension is shown in Figure 10.

Note: Whenever the nozzle (1B or 2) seat has been remachined, the lift stop (8) should be reset according to paragraph, "Setting of the Lift Stop" on page 15.

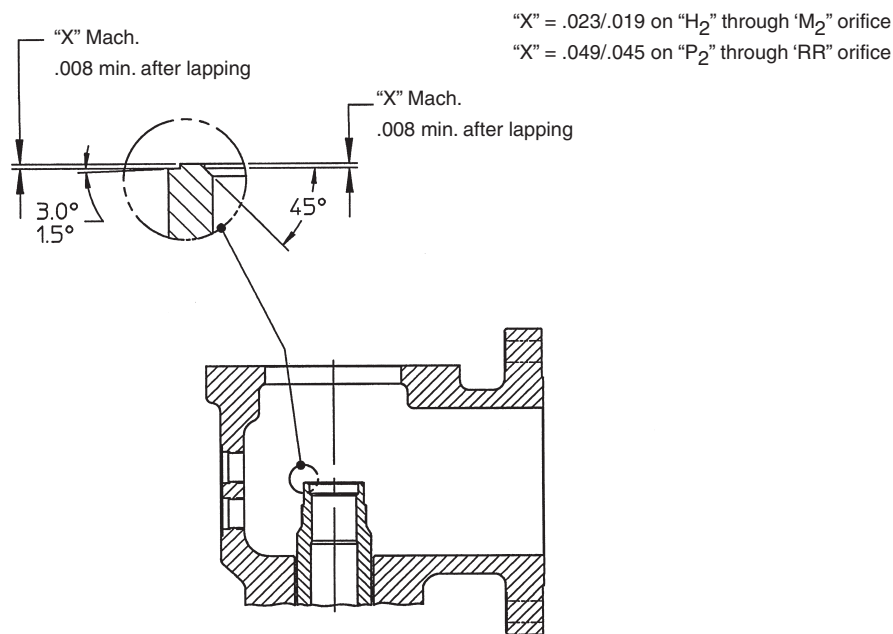
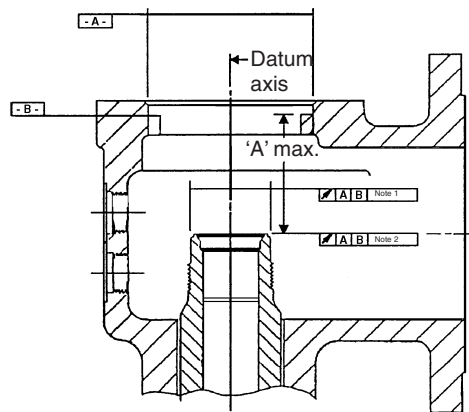
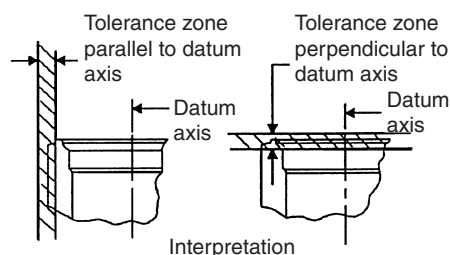

Figure 11 - Nozzle Seat Critical Dimensions

Table 4 - Maximum "A" Dimension

Orifice and Valve Class						
H ₂	J ₂	J ₂	K ₂	K ₂	L ₂	L ₂
3(-) - 9()	3(-) - 6()	7(-) - 9()	3(-) - 6()	7(-) - 9()	3(-) - 6()	7(-) - 9()
3.068 in	3.224 in	4.161 in	4.161 in	4.911 in	4.911 in	5.411 in
77.9272 mm	81.890 mm	105.689 mm	105.689 mm	124.739 mm	124.739 mm	137.439 mm
Orifice and Valve Class						
M ₂	M ₂	P ₂	Q ₂	R ₂	RR	
3(-) - 6()	7(-) - 9()	3(-) - 6()	3(-) - 6()	3(-) - 6()	3(-) - 5()	
4.911 in	5.411 in	5.411 in	6.911 in	8.411 in	9.161 in	
12.739 mm	134.439 mm	137.439 mm	175.539 mm	213.639 mm	232.689 mm	

Figure 10
Body to Nozzle Seat Dimensions



Notes

- Maximum tolerance zone for surface parallel to datum axis:
 For Orifice H₂ .006
 For Orifice J₂ through M₂ .009
 For Orifices P₂ and larger .011
- Maximum tolerance zone for surface perpendicular to datum axis:
 For Orifices H₂ through M₂ .0015
 For Orifices P₂ and larger .002

Valve Assembly

- Apply a light coat of “Never-Seez” lubricant on the new nozzle ring (3) threads. Screw the nozzle ring on the nozzle (1B or 2) leaving the top of the ring slightly above the seating plane. This will help protect the seating surface of the nozzle during the assembly processes.
- Spot lap the disc insert (5) to the spindle (14) and clean thoroughly. Apply a thin coat of “Molykote 321R” dry film lubricant to the bearing surface of the disc insert and spindle tip.
- Apply a light coat of “Never-Seez” to the threads of the spindle (14), disc insert (5) and disc holder retainer (7). If applicable, apply a light coat of “Never-Seez” to the threads of the lift stop (8) and thread the lift stop onto the spindle.
Note: Do not install the lift stop cotter pin (10) at this time.
- Thread the disc holder retainer (7) onto the spindle (14) and slide the disc holder (6) over the lower end of the spindle. Thread the disc insert (5) onto the spindle and set the retainer clearance. See Figure 12. Install the disc holder retainer cotter pin (9).
Note: The cotter pin ends should be bent over so as not to protrude from the outside diameter of the disc holder retainer.
- Spot lap the guide (11) with the mating surface on the body (1A) and clean the surface thoroughly. Then place the guide into position on the body.
- If assembling a restricted lift valve, set the lift stop (8) according to paragraph, “Setting of the Lift Stop” on page 15.
- With the new disc holder (6), disc insert (5), disc holder retainer (7) and spindle (14) assembled, place the assembly into position in the body and guide (11).
- Place the new spring (15) and washer assembly (16 and 17) into position on the bonnet (20). Note that the antirotation plate of the top spring washer should be straddling the bonnet.
- The valve can be assembled further using either of the two methods described in paragraphs on page 16, “Spring Assembly With (or Without) the Use of the Jacking Device.” One method may be preferred over the other depending on the valve size and/or set pressure.

Stand assembly on a clean surface making certain that the end of the spindle rotates freely on the disc insert bearing surface (not loading on the insert threads). Thread the disc holder retainer down until it makes contact with the disc holder. Locate the hole in the spindle relative to a notch on the retainer. Back off the retainer by turning it counterclockwise to establish the proper clearance. The clearances, and the corresponding number of notches, are listed in the table below. With the proper clearance established, install the retainer cotter pin through the appropriate notch and spindle.

Figure 12
 Retainer Nut Clearance

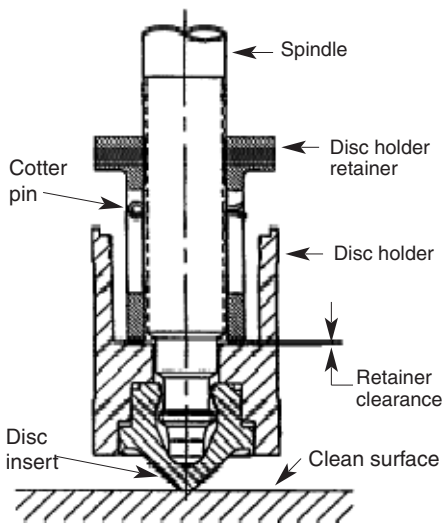

CAUTION
 The cotter pin head should be turned so that it fits between the into the retainer notch and makes contact with the spindle. The split ends of the cotter pin should both be bent downward.

Table 5

Valve Orifice Size	Retainer Corresponding Clearance	Number of Retainer Notches
H ₂	.009-.013	2-3
J ₂	.010-.015	2-3
K ₂	.010-.015	2-3
L ₂ 3() - 6()	.010-.015	2-3
L ₂ 7() - 9()	.012-.013	2
M ₂	.012-.013	2
P ₂	.012-.013	2
Q ₂	.010-.015	2-3
R	.010-.015	2-3
RR	.010-.015	2-3

Setting of the Lift Stop

It is recommended that a factory trained TV&C Field Service Technician is used to perform the setting of the lift stop. In order to set the lift stop (8), first lower the nozzle ring (3) below the plane of the nozzle (1B or 2) seat.

CAUTION
 In order to establish the proper lift, the disc and nozzle seats must be brought into contact. For this reason, extreme caution should be exercised to prevent damage of the seating surfaces.

- With the new disc holder (6), disc insert (5), disc holder retainer (7), spindle (14) and lift stop (8) threaded roughly in place, carefully lower the assembly into the guide (11) until the disc insert is seated on the nozzle (1B or 2).
- The lift stop setting may now be accomplished by first installing the valve bonnet (20) in place on the guide (11). If the valve spring compression has been retained, the complete assembly may be used.
- Holding the spindle (14), thread the lift stop (8) upward until contact is made with the bonnet (20). Using table 5 on page 15 and the formula provided, determine the appropriate number of notches required to attain the lift stamped on the valve nameplate.
Note: Do not deviate from the “restricted lift” stamped on the valve nameplate.
- Turn the lift stop (8) downward the required number of notches, remove the bonnet (20) and install the lift stop cotter pin (10).
Note: The cotter pin ends should be bent over so as not to protrude from the outside diameter of the lift stop.
- Complete the valve assembly per the standard instructions.

Table 6 - Lift Stop Setting Information

Orifice Size	Pressure Class	Inches of Lift per Slot on Lift Stop (A)	Margin for Thermal Growth in Notches
H ₂	3() through 9 ()	0.0045	4
J ₂	3() through 9 ()	0.0052	4
K ₂	3() through 9 ()	0.0052	5
L ₂	3() through 6 ()	0.0052	7
L ₂	7() through 9 ()	0.0063	6
M ₂	3() through 9 ()	0.0063	8
P ₂	3() through 6 ()	0.0063	9
Q ₂	3() through 6 ()	0.0052	13
R	3() through 6 ()	0.0052	15
RR	3() through 6 ()	0.0052	17

Formula : # Notches = (Nameplate Restricted Lift ÷ (A)) + (Margin)

Note : The number of notches shall be rounded up to the nearest whole number.

- Spring Assembly
Assembly of the valve superstructure and the compression of the spring may be accomplished by two different methods as follows:
- Spring Assembly Without Using the Hydraulic Jacking Device
Utilizing a suitable lifting device, place the bonnet/spring assembly over the spindle (14) and into position on the body (1A). Note that the adjusting bolt (23) will be in the retracted position thereby allowing the bonnet (20) to be seated on the body. With the assembly in place, turn the nozzle ring (3) clockwise (with a screwdriver through the set screw hole) until the top surface is below the seating plane. The bonnet stud nuts (22) may now be retorqued in place. Note that a criss-cross torquing pattern should be utilized to ensure even compression as illustrated in Figure 4 on page 8. Once the bonnet stud nuts are in place, the adjusting bolt(23) may be turned, thereby compressing the valve spring (15). The adjusting bolt should be tightened until the desired spring compression value during disassembly is obtained. At this point the adjusting bolt nut (24) shall be tightened in place.
Note: The setting of the spring compression by this method is only a very rough estimate of the valve set pressure. The valve will require set pressure testing prior to returning to service (refer to paragraph, “Set Pressure Testing and Valve Adjustments,” on page 9).
- Spring Assembly Using the Hydraulic Jacking Device
Set the adjusting bolt (23) to the dimension recorded during disassembly and tighten the adjusting bolt nut (24). Utilizing a suitable lifting device, place the bonnet/spring assembly over the spindle and into position on the body.
Note that because the adjusting bolt is in a down position the bonnet (20) will be slightly raised above the surface of the guide (11).

Referring to Figure 13 on page 17:

- Install the bonnet spacer on the bonnet. Position the jacking device assembly by lifting over the spindle and lowering down on the bonnet spacer.



CAUTION

The piston (2) should be seated within the housing (1) before continuing. This seated position is reached when the first notch on the piston (2) is level with or below the top of the housing (1) as illustrated in Figure 13.

Figure 13
Hydraulic Jacking Device

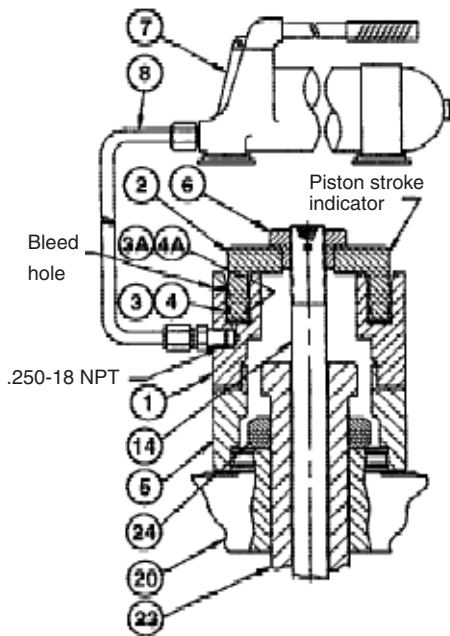

Parts list

Item	Part name
1	Housing
2	Piston
3*	O-ring
3A*	O-ring
4*	Back-up ring
4A*	Back-up ring
5	Bonnet spacer
6	Spindle adaptor
7	Hydraulic pump
8*	1/4" Hose
14	Valve spindle
20	Bonnet
23	Adjusting bolt
24	Adjusting bolt nut

* Recommended spare parts

- Lubricate the spindle threads with a light coat of "Never- Seez", "Molykote-G" or equivalent. Thread the appropriate spindle adapter (6) on the spindle until it comes in contact with the jacking device piston. Attach the hand-operated hydraulic pump (7) and hose (8).
- To raise the valve, spindle pressure is applied to the jacking device assembly with the handoperated hydraulic pump. This activates the piston (2) which will rise, compressing the spring in the process.



CAUTION

This device has a limited piston stroke that should not be exceeded. If the piston stroke is exceeded, the second notch on the piston (2) will be above the top of the housing (1) and hydraulic fluid will flow from the bleed hole located in the housing. If hydraulic fluid is flowing from the bleed hole but the piston stroke has not been exceeded, the O-ring (3) and the backup ring (4) should be inspected for wear or damage and replaced if necessary.



WARNING

Never jack the spindle so that the lift stop contacts the bonnet. For smaller orifice valves this distance is 5/16". For restricted lift valves this distance is the lift stamped on the nameplate.

- Lift the valve spindle approximately 1/8". At this point the force of the spring will have been taken up by the jacking device and the bonnet will lower.
- Replace the bonnet stud nuts (22) and tighten as much as possible.
- Now transfer the spring load back to the bonnet studs (21) by relieving the pump hydraulic pressure. This may be accomplished by turning the pump vent valve to open. This will act to lower the jacking device piston.

Once the piston has returned to the lower position, adjust the spindle adapter so that it once again is in contact with the jacking device piston. Repeat the steps of the above paragraphs as many times as necessary to fully compress the spring and to firmly seat the bonnet on the guide.

Note: The setting of the spring compression by this method is only a very rough estimate of the valve set pressure. The valve will require set pressure testing prior to returning to service (refer to paragraph, "Set Pressure Testing and Valve Adjustments" on page 9.)

Table 7 - Crosby part numbers for manual jacking device for Crosby HCI valves

Assembly SA-52980 is always required.

The spacer and adapter are required as shown in the table below

Piece Description	Orifice and Valve Class										
	H ₂	J ₂	J ₂	K ₂	K ₂	L ₂	M ₂	P ₂	Q ₂	R	RR
Bonnet	3(-)-9()	3(-)-6()	7(-)-9()	3(-)-6()	7(-)-9()	3(-)-9()	3(-)-9()	3(-)-6()	3(-)-6()	3(-)-6()	3(-)-5()
Spacer	086418	086428	086428	086418	None	None	None	None	18640	108640	108640
Spindle Adapter	083551	146131	082893	082893	083508	083508	083508	083508	146135	146135	146132

Notes

- Assembly SA55848 consists of Pc. Nos. 1, 2, 3, 3A, 4, 4A, 7, 8.
- Spacer (Pc. No. 5) and Adapter (Pc. No. 6) must be selected from table 7.
- Assembly SA52980 consists of Pc. Nos. 1, 2, 3, 3A, 4, 4A

Setting of Rings

The nozzle ring (3) setting is stamped on the machined surface of the bonnet (20) where the cap (25) sits. For example, NR-15 means set the nozzle ring fifteen notches below contact with the disc holder. To set the nozzle ring, turn it to the right (counterclockwise) until it touches the disc holder (6). From this position lower it by the number of notches indicated to the stamped position.

The guide ring (12) setting is obtained in the same manner as the nozzle ring above. For example, GR +30 means thirty notches above level position. Level is when the bottom of the guide ring is even (level) with the bottom of the disc holder (6). This position is illustrated in Figure 7 on page 10. With the safety valve already on the system, level can be obtained by inserting a metal rod with a hook on the end through the lower set screw hole and feeling the position of the ring in relation to the disc holder.

To set the guide ring (12), move it to the level position. If the stamped guide ring position is a positive number, turn the ring to the right (counterclockwise) to raise the guide ring by the number of notches indicated. If the stamped guide ring position is a negative number, turn the ring to the left (clockwise) to lower the ring that number of notches.

Lubricate the set screws (4 and 13) threads. Screw the set screws into the body (1A) engaging both the nozzle ring (3) and guide ring (12). Both rings should be able to move back and forth slightly after the set screws are tightened.

Assembly of Cap (See Figure 1 on Page 2)

The assembly of the cap is referred to several times in this instruction. The cap assembly consists of the spindle nut (33); cap (25); forked lever assembly (30), (forked lever, forked lever pin and forked lever pin cotter); and the lever assembly (27) (lever, lever pin and lever pin cotter). The lever assembly can be removed from the safety valve independently of the cap. The cap cannot be removed from the safety valve without first removing the forked lever assembly. The cap set screws are seal wired to prevent tampering with the adjusting bolt (23).

To assemble the cap assembly, proceed as follows:

- If the spindle nut (33) was removed, lubricate the spindle rod (14) threads and install the spindle nut and the spindle nut cotter (34). Install the lever, lever pin and lever pin cotter. Place the cap in position but do not tighten the cap set screws yet.
- Install the forked lever, forked lever pin and forked lever pin cotter. Be sure that the forked lever is free to move from $\frac{1}{16}$ " to $\frac{1}{8}$ " before coming into contact with the spindle nut. If travel is excessive, remove the forked lever and cap and turn the spindle nut clockwise or counterclockwise to increase or decrease the forked lever travel. Be sure spindle nut cotter is installed after the final adjustment.

Spare Parts

Crosby recommends spare parts as shown on the parts list, Figure 1, page 2 with corresponding notes on page 2. When ordering spare parts, the valve assembly number should be given together with part number and valve size and style. The valve assembly number is shown on the valve nameplate as Shop Number (see page 1). Any Crosby Sales Office or Representative can expedite your spare parts requirements.

Field Service Requirements

Field Service

Crosby operates an extensive field service organization capable of adjusting, setting and maintaining Crosby valves worldwide. Service technicians are located throughout the United States for fast response to our customers' needs.

Service Technicians are Factory trained and are long experienced in servicing safety valves. It is strongly recommended that on new installations a Crosby Service Technician be present for assembly and testing of safety valves.

Field Service Technicians are coordinated through the Stafford, Texas office. Contact: Field Service Department, Service Manager, Crosby; 3950 Greenbriar, Stafford, Texas 77477 (phone 281-274-4476)

Service Equipment Available

All service equipment mentioned in this instruction is available for purchase or rental. Any Crosby Sales Office, Representative or Service Manager can expedite your service equipment requirements. (See page 17)

Crosby Maintenance Equipment

All service equipment mentioned in this instruction is available for purchase or rental and any Crosby Regional Office, Representative or Service Manager can expedite your service equipment requirements.

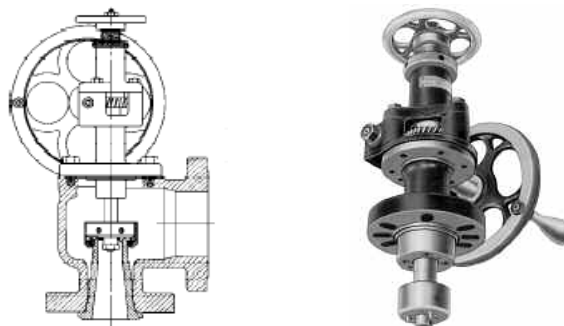

Reseating Machines

Reseating Machines

Crosby reseating machines will remachine the nozzle seats in place without removing the safety valve from the installation. Form cutters are used to cut a new seat to exact dimensions. Reseating machines, cutters and auxiliary equipment may be rented or purchased. Contact the Factory.

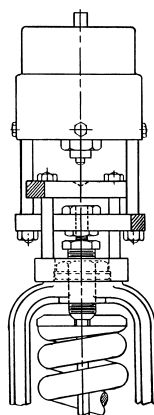

Air Set Pressure Device

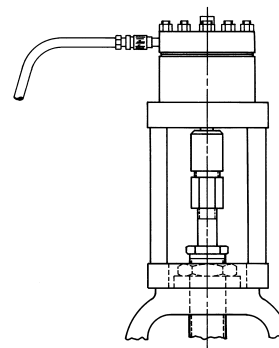

Hydraulic Set Pressure Device

Jacking Devices

When a safety valve is to be disassembled and it is desired to retain spring compression, i.e., the set pressure, a mechanical or hydraulic jacking device may be used. Jacking devices are used to lift the bottom spring washer sufficiently to allow the disc or disc insert to lift clear of the nozzle (permitting the entire bonnet assembly to be removed). Jacking devices may be rented or purchased. Contact the Factory.

Set Pressure Devices

The set pressure of safety valves may be determined without raising system pressure to the popping pressure of the valves by using a Crosby set pressure device which may be rented or purchased.

The apparatus consists of a lifting device mounted on the bonnet and connected to the spindle of the safety valve. The differential force required to open the safety valve when the system (steam) pressure is less than the valve set pressure is applied by the operator. The differential force at which the valve opens is determined and the safety valve set pressure is calculated from this measurement. Contact the Factory.

Tyco Valves & Controls

www.tycovalves.com

Tyco Flow Control (TFC) provides the information herein in good faith but makes no representation as to its comprehensiveness or accuracy. This Engineering document is intended only as a guide to TFC products and services. Individuals using this Engineering document must exercise their independent judgment in evaluating product selection and determining product appropriateness for their particular purpose and system requirements. TFC MAKES NO REPRESENTATIONS OR WARRANTIES, EITHER EXPRESS OR IMPLIED, INCLUDING WITHOUT LIMITATION ANY WARRANTIES OF MERCHANTABILITY OR FITNESS FOR A PARTICULAR PURPOSE WITH RESPECT TO THE INFORMATION SET FORTH HEREIN OR THE PRODUCT(S) TO WHICH THE INFORMATION REFERS. ACCORDINGLY, TFC WILL NOT BE RESPONSIBLE FOR DAMAGES (OF ANY KIND OR NATURE, INCLUDING INCIDENTAL, INDIRECT, OR CONSEQUENTIAL DAMAGES) RESULTING FROM THE USE OF OR RELIANCE UPON THIS INFORMATION. Patents and Patents Pending in the U.S. and foreign countries. Tyco reserves the right to change product designs and specifications without notice.