

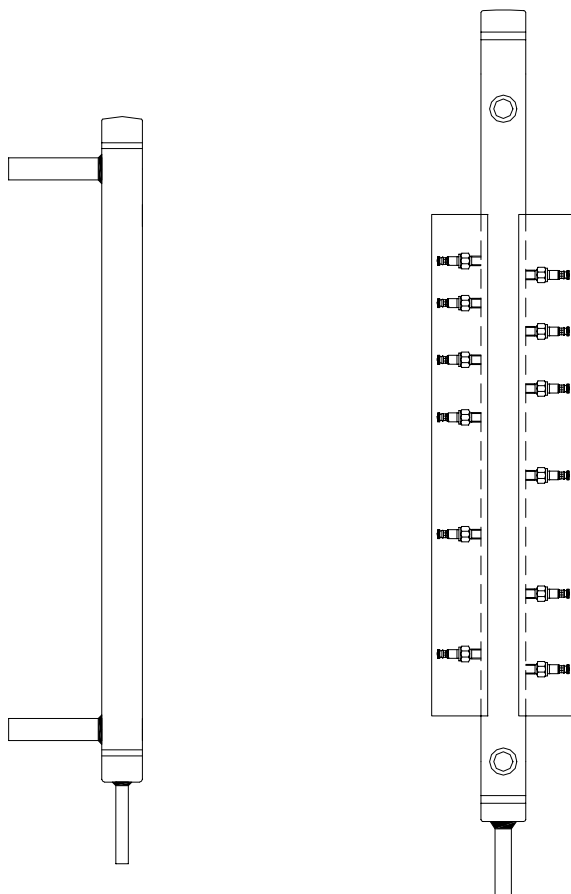

Installation, Operation and Maintenance for Yarway Water Column



Installation, Operation and Maintenance
Instructions

TABLE OF CONTENTS

Product Warranty	iii
1.0 Description	1
2.0 Supply & Installation	1
2.1 Packing	1
2.2 Water Column	1
2.3 Probes	2
2.3.1 HP Probes	3
2.3.2 LP Probes	4
2.4 Wiring	4
3.0 Startup And Operation	4
4.0 Maintenance	5
4.1 Water Column	5
4.2 Probes.	6
5.0 Spare Parts	7
6.0 Specifications	7
7.0 Disposal at End of Useful Life	8
8.0 Telephone Assistance / Factory Repair	9

Table of Figures

Figure # 1 - Water Column Installation	2
Figure # 2 - Probe Assembly	3
Figure # 3 - Ground Connection Location	4

YARWAY PRODUCT WARRANTY

Tyco Valves & Controls Prophetstown warrants its Yarway products as designed and manufactured by TV&C Prophetstown to be free of defects in the material and workmanship for a period of one year after the date of installation or eighteen months after the date of manufacture whichever is earliest. TV&C Prophetstown will, at its option, replace or repair any products which fail during the warranty period due to defective material or workmanship.

Prior to submitting any claim for warranty service, the owner must submit proof of purchase to TV&C Prophetstown and obtain written authorization to return the product. Thereafter, the product shall be returned to TV&C in Prophetstown, Illinois, with freight paid.

This warranty shall not apply if the product has been disassembled, tampered with, repaired or otherwise altered outside of TV&C Prophetstown factory, or if it has been subject to misuse, neglect or accident.

The responsibility of TV&C Prophetstown hereunder is limited to repairing or replacing the product at its expense. TV&C Prophetstown shall not be liable for loss, damage or expenses related directly or indirectly to the installation or use of its products, or from any other cause or for consequential damages. It is expressly understood that TV&C Prophetstown is not responsible for damage or injury caused to other products, buildings, personnel or property, by reason of the installation or use of its products.

THIS IS TV&C PROPHETSTOWN'S SOLE WARRANTY AND IN LIEU OF ALL OTHER WARRANTIES, EXPRESSED OR IMPLIED WHICH ARE HEREBY EXCLUDED, INCLUDING IN PARTICULAR ALL WARRANTIES OF MERCHANTABILITY OR FITNESS FOR A PARTICULAR PURPOSE.

This document and the warranty contained herein may not be modified and no other warranty, expressed or implied, shall be made by or on behalf of TV&C Prophetstown unless made in writing and signed by the General Manager or Director of Engineering of TV&C Prophetstown.

INSTALLATION, OPERATION and MAINTENANCE MANUAL FOR YARWAY WATER COLUMN

1.0 Description

Yarway water columns are designed and manufactured in accordance with ASME Boiler & Pressure Vessel Code. They are used for gage support and to reduce transient level fluctuations, and when probes are installed, they are used as part of an electronic level indicating system.

2.0 Supply & Installation

2.1 Packing

Prior to installing this equipment clean all packing material from around the unit and inspect for any damage that may have occurred during shipment. Any claims for loss or damage must be filed by the purchaser with the carrier. A copy of the bill of lading and freight bill will be supplied on request by TV & C – Prophetstown.

2.2 Water Column (see figure 1)



WARNING



The nature of the electronics, the harsh operating environment and the potential hazards associated with live steam require that only qualified personnel install and maintain this equipment. Without adequate qualifications, an operator could allow live steam to escape which may cause property damage or severe personal injury.

For safety reasons, it is important to take the following precautions before starting work on the remote level indicator:

- (1) The lines that the water column is to be installed to must be depressurized, drained and vented before installing the water column.
- (2) Handling and installation of the remote level indicator must be carried out by personnel trained in all aspects of installation and manual/mechanical handling techniques.
- (3) Welding must be performed only by personnel qualified and certified to all applicable national and local codes.
- (4) Before making any electrical connections, ensure that the power source to be used is isolated by use of the appropriate circuit breakers and/or switches.

All wiring must be in accordance with applicable national and local codes by qualified personnel only.

The water column is fixed to the steam drum either by being welded directly to the isolating valves or welded to flanges that mate with existing flanges on the steam drum tapping points. A steam inlet line must be installed to provide a free flow of steam to the water column. The steam line must slope down toward the column (a slope of 2% is recommended). When globe valves are used as the isolation valves, they must be installed with the stem horizontal. Ideally, the return water leg should be horizontal. This leg may, however, be

sloped down to the drum, in which case it must be insulated. In no case should the steam line or water column be insulated. Insulating these inhibits condensation, which is essential for proper circulation through the water column.

Water Columns with three maximum pressure ratings are available – 850 psig [58 barg], 1800 psig [124 barg] and 3000 psig [206.9 barg] design. The fittings on steam generators of lower pressure usually have a lesser rating. As a result, the overall rating of a system is governed by the lowest rating of any of the components.

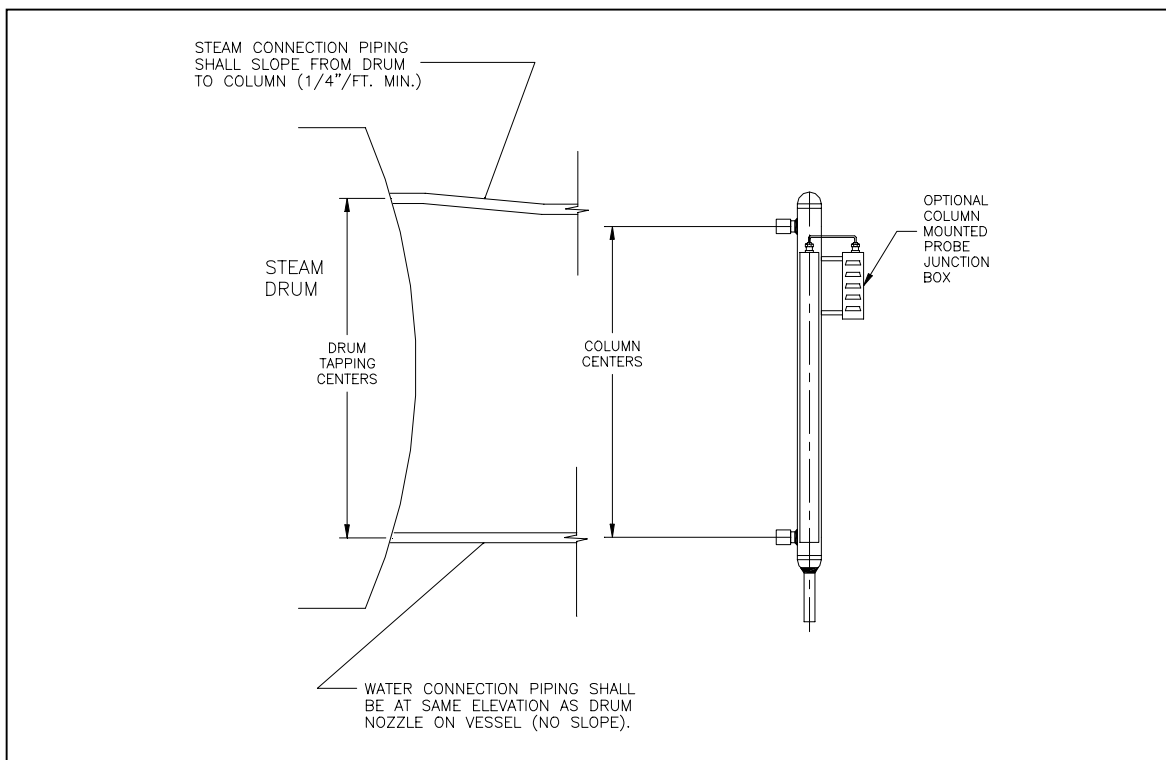

Figure 1 – Water Column Installation

2.3 Probes (if supplied)

The metal probe covers should be removed from the water column after it is fully plumbed into the system and remain off until the system is in service and a satisfactory inspection of all the probes and the associated wiring is completed.

The water column is supplied with either of two probe styles, if used with a remote level indicating system. For applications below 525°F [274°C] / 850 psig [58 barg], an economical probe is available with a PTFE wetted insulator. It can not be used if either parameter (525°F [274°C] or 850 psig [58 barg]) is exceeded.

For all other applications, probes with the zirconium oxide (ceramic) insulators must be used. The high pressure (HP) probes are easily recognized by the brazing between the insulator and the body (Fig 2). The two styles of probes are not interchangeable and will not fit in a receptacle designed for the other. LP probes use a threaded fitting, the HP a compression fitting.

Note: The probe hex nut and hex jam nut located on the post used for the electrical connection have been pre-torqued to exact specification. If the hex nuts are inadvertently moved, the probe must be replaced.

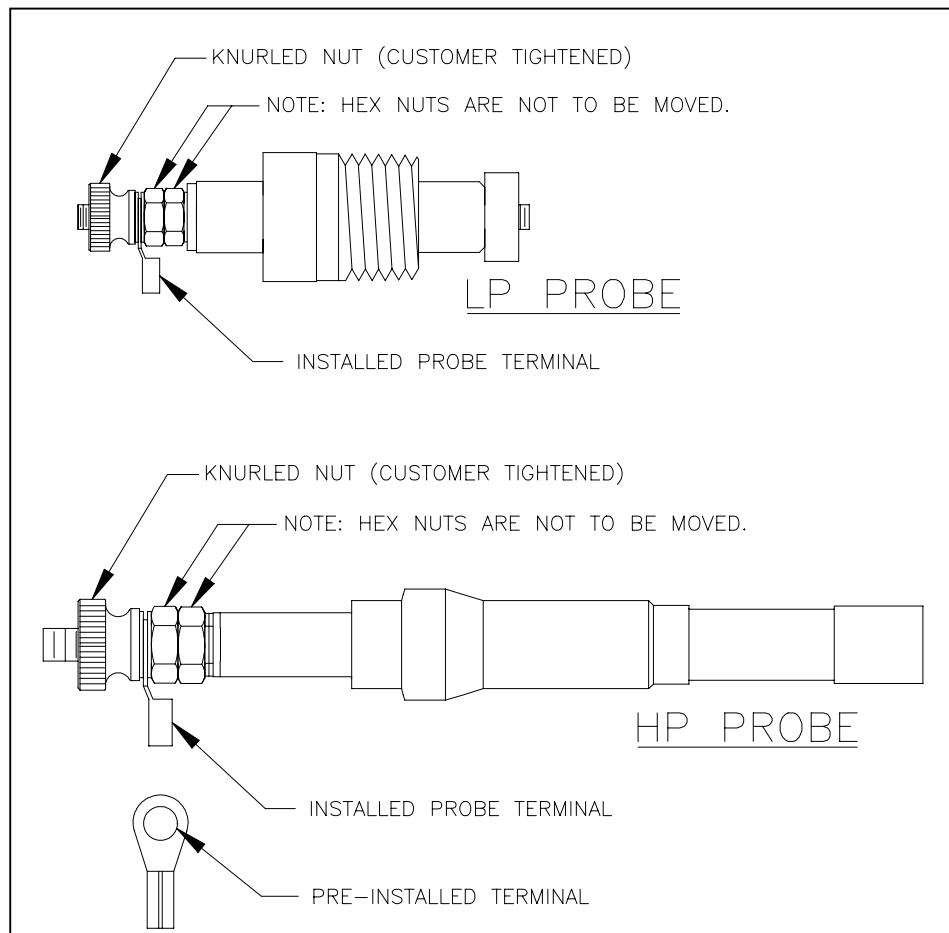

Figure 2 – Probe Assembly

2.3.1 HP Probes

- (1) Probes are supplied fully assembled. Probe receptacles on the water column are ½" swaged fittings.
- (2) Ensure that the receptacle and probe retaining nut threads and sealing surfaces are clean. The threads on the receptacle and probe retaining nut should be lubricated with an anti-seize compound to prevent galling and lower the tightening torque on the threaded parts. Recommended compounds include:
 - Silver Goop (Swagelok trade name)
 - MP-50 Moly Paste (Jet Lube of Canada)
 - Never-Seez (trade name)
- (3) Insert the probe into the receptacle and tighten the probe retaining nut by hand. With a wrench, further tighten the nut ¼ turn only. Subsequent connections will be made in a similar manner.

2.3.2 LP Probes

- (1) Probes are supplied fully assembled. Probe connections on the water column are 3/8" NPTF.
- (2) Using 1/2" wide high-quality Teflon tape, wrap 2-3 turns of tape around the probe threads in the same directions that the probe is tightened. If the Teflon tape is wrapped the wrong direction, the tape will not protect the threads during the torquing process.
- (3) Tighten the probe to a torque value of 35-40 ft-lbs [156-178 N•m].

2.4 Wiring

For proper operation of the electronics, the system must be properly grounded. When the water column is supplied with probe covers, there is a column ground located on the underside of each probe cover upper bracket. When individual probe housings are supplied, each housing has a separate ground connection. See Figure 3.

For complete wiring details, refer to the manual for the particular model of level indicating device supplied.

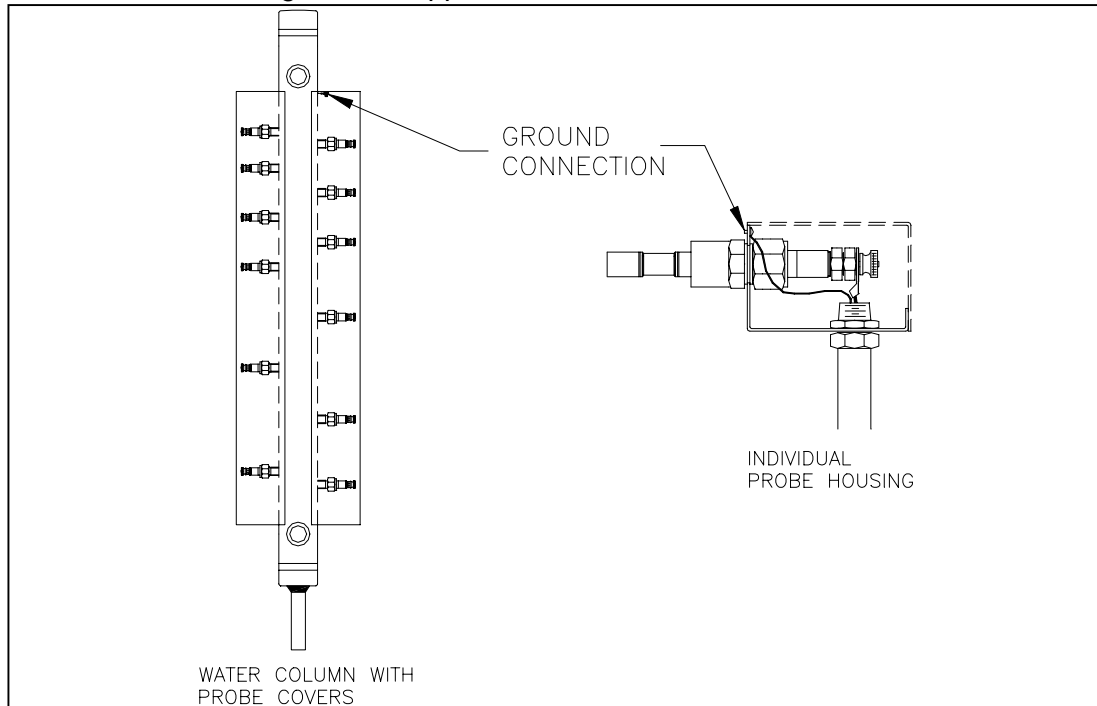

Figure 3 - Ground connection location

3.0 Startup and Operation

To place the water column in service the following procedure is recommended:

- (1) Inspect the water column to ensure that all the probes are installed and the associated wiring is correct and all connections are secure. Wiring should be neatly routed and any contact between the high temperature water column body or the probe cover should be avoided.

- (2) Open the blowdown valve.
- (3) Crack the steam block valve and warm up the water column for a period of 3 to 5 minutes with low velocity steam.
- (4) At the end of the warm-up period, close the blowdown valve and then fully open the steam valve.
- (5) The water connection block valve should now be opened, or alternately, if this valve is left closed, the vessel will fill with condensate allowing the operating range to be verified.
- (6) The water block valve must then be fully opened.
- (7) Visually check all the probes for any sign of leaks. Replacement of the probe cover using the ¼" socket head cap screws will complete the commissioning of the water column.

Notes:

- (8) The metallic sensing tip of any probe may self-passivate or the probe insulator may retain a slightly conductive film from processing. A "hot start" as outlined above will clear any residual passivation or coating. Attempting to commission a water column with probes using cold water, such as during a hydrostatic test, cannot guarantee proper probe wetting. The display/relays may therefore generate a random output commonly called "checkerboarding". Pre-cleaning the probes (see section 4.2 (3)) will also eliminate this potential commissioning problem.
- (9) Isolation and blowdown valves should be carefully selected and installed as outlined in ASME Boiler & Pressure Vessel Code, Section I. Yarway Welbond valves, Series 5600, are recommended.
- (10) During vessel blowdown, isolation or testing, some form of interlocking bypass of the high and low water control outputs may be required to avoid boiler tripping.

4.0 Maintenance

Each boiler installation is subject to varying operating and water conditions. Generally, the higher operating pressure units (>1800 psig [125 barg]) have improved water treatment and, as such, maintenance is minimized.

4.1 Water Column

A specific maintenance program is difficult to detail but the following outlines the minimum required: The water column should be blown down periodically and visually inspected for leaks every 3 months.

4.2 Probes



WARNING



Before servicing the probes, ensure that the water column is properly isolated from the system, all pressure has been relieved and the unit cooled to an acceptable level, otherwise severe personal injury and property damage may occur.

Note: The voltage to the probes from the electronic module is 24 Vac RMS or less for all Yarway remote level indicating devices. The power, therefore, does not have to be turned off when working with the probes. Probe tips may be shorted to ground but should never be subjected to another voltage source. Assuming trouble-free operation, probes should be inspected after the first 12 months. Thereafter, they should be inspected as required, depending upon the degree of contamination found at first inspection.

- (1) **HP Probe:** Loosen the probe retaining nut approximately 1 turn and then free the probe to verify all pressure has been relieved. The metal to metal sealing surface initially may cause the probe to stick, so carefully free the joint by tapping the probe on the metal body. Do not strike the zirconia insulator and do NOT turn the probe hex head nuts or the probe will be destroyed. After the probe becomes free, loosen the probe retaining nut fully and remove the probe.
LP Probe: Loosen the probe slowly. If any steam or water begins to vent, stop immediately and ensure that the column is isolated from the system and pressure has been relieved.
- (2) Severe deposits on the probes indicate that inspection should be more frequent. A common household powdered cleaner may be used to clean the probe body and the insulator. After cleaning, the probes should be wiped off with a dry, clean cloth. Do not immerse the probe in liquids. Probes that show any signs of damage, insulator cracking, or steam leaks must be replaced immediately. Do not attempt disassembly of the probe components.
- (3) The integrity of the probe can be checked by using an ohmmeter. Resistance measurement across the insulator of 10 MΩ or greater indicates the probe is performing satisfactorily. If the system is selected for detection of high conductivity water (greater than 25 μS), a probe resistance measurement of 1 MΩ or greater may be considered satisfactory. For an ultra high sensitivity system option (<1μS conductivity), 20MΩ is minimum.
- (4) After the probes have been inspected, cleaned and tested, they can be installed following the steps outlined in the probe installation procedure section.

- (5) Do not leave an open probe receptacle on the water column. If for any reason a probe is not immediately re-installed, the port should be plugged with Yarway HP Part No. 964584-19 or Yarway Part # 10675-022 for LP probes and tightened following the probe installation procedure.
- (6) The unit can now be returned to service by following the steps outlined in the start-up procedure (see Startup and Operation, Section 3).

5.0 Spare Parts

The following spare parts are recommended as a minimum set for stocking by the user:

Probes: stock 1 for every 6 probes in service
A copy of this I.O.M.

Probes are available only as complete new assemblies.
Consult your Tyco or Yarway distributor or TV&C-Prophetstown.

6.0 Specifications *

Standard Ratings:	3000 psig [207 barg] @ saturation 1800 psig [124 barg] @ saturation 850 psig [58 barg] @ saturation
Standard Material:	SA 106 GR B UNS K03006 Up to $T_{max} = 1000^{\circ}F$ [$538^{\circ}C$] HP 3" NPS seamless pipe, schedule XXS body IP 3" NPS seamless pipe, schedule 160 body LP 3" NPS seamless pipe, schedule 160 body 1 1/2" NPS vessel stub connections 3/4" NPS drain stub connection
Probe covers:	stainless steel, IP32
Probe wiring:	36" high temperature wire from conduit
HP probe:	welded stainless steel w/ zirconia insulator 3000 psig [207 barg] @ saturation, up to $1000^{\circ}F$ [$538^{\circ}C$]
LP probe:	threaded stainless steel w/ Teflon® insulator 850 psig [58 barg] @ $525^{\circ}F$ [$274^{\circ}C$]
Manufacturing Standards:	ASME B&PV Section I, ASME B31.1

Standard Options:

- Pre-wired column mounted junction box (type 3R / IP22)
- Flanged connections on vessel connections or vent/drain
- Female socket weld connections
- Reducing fittings on vessel connections or vent/drain
- Weldolet / Bosset connections
- 3/4" stub vent connection
- Welded support brackets
- Optional materials of construction:
 - SA 335 GR P22 UNS K21590
 - SA 312 TP316 UNS S31600
 - SA 335 GR P11 UNS K11597
 - SA 335 GR P91 UNS K90901
 - SA 312 TP304 UNS S30400

*Specifications and descriptions are subject to change without notice.

7.0 Disposal at End of Useful Life

The water column may be used in a variety of fluid applications. By following the appropriate national and industry regulations, the user must determine the extent of preparation and treatment the water column must incur before its disposal. A Material Safety Data Sheet (MSDS) may be required before disposal services accept certain components.

Metal, glass and polymers should be recycled whenever possible. Refer to order and TV&C - Prophetstown Material Specification sheets for materials of construction.

8.0 Telephone Assistance / Factory Repair

If you are having difficulty with your water column, contact your local Tyco / Yarway distributor. You may also contact the factory direct at (815) 537-2311 and ask for an applications engineer. So that we may assist you more effectively, please have as much of the following information available when you call:

Model #

Serial #

Name of the company from whom you purchased the water column

Invoice # and date

Process conditions (pressure, temperature, cycle rate, etc.)

A brief description of the problem

Troubleshooting procedures that failed

If attempts to solve your problem fail, you may request to return your water column to the factory for intensive testing. You must obtain a Return Authorization (R.A.) number from TV&C - Prophetstown before returning anything. Failure to do so will result in the unit being returned to you without being tested, freight collect. To obtain an R.A. number, the following information (in addition to that above) is needed:

Reason for return

Person to contact at your company

"Ship To" address

There is a minimum charge of \$75.00 for evaluation of non-warranty units. You will be contacted before any repairs are initiated should the cost exceed the minimum charge. If you return a unit under warranty, but is not defective, the minimum charge will apply.

Notes

Notes

Notes



Tyco Valves & Controls, L.P. Prophetstown
320 Locust St., Prophetstown, Illinois 61277
Phone: 815-537-2311
FAX: 815-537-5365
Printed in USA
Part No. 18LJ3-009

© 2002 TV&C, L.P. Prophetstown, All Rights Reserved