



**KLB wafer style linear line blind offers value, high performance and safety in a compact package.**

### Features

- Linear line blind simplifies a difficult, time-consuming process.
- No need to spread the the pipe to blank the line, actuation can be automated.
- Visual confirmation of the blank from all sides.
- Standard with closed position dual-function lock-out assembly.
- Detachable pin removes potential energy from actuator.
- Lock-out pin prevents unwanted blind movement.
- 100% Isolation-bubble tight shut-off results in absolutely zero downstream leakage, a true man-safe line blind.
- Patented, field replaceable elastomer sleeves available in a wide range of elastomers to meet varied applications.
- No seat cavity where solids can collect and prevent full blank closure.
- Adaptable yoke design featuring a top-removal stem nut, can be field modified to an air cylinder or bevel gear in the field.
- Linear line blinds above 24" are available including sizes up to 54". Contact your sales representative for complete details.



### General Applications

- Mining
- Power
- Pulp and paper
- Alumina
- Chemical
- Cement

### Technical Data

- Size range: 2" to 16" rated to 150 psi  
18" to 24" rated to 90 psi
- Sleeve: Gum rubber standard
- Temperatures: Standard sleeve rated to 160°F, up to 300°F with proper elastomer selection

# Clarkson KLB Wafer Style Slurry Knife Gate Valve

2" to 24"

## How the KLB Sleeves Work

Matching sleeves are placed in the KLB linear line blind housing to seal against each other when the blind is open, allowing full flow of the media and to seal against the blank when the blind is closed, fully isolating the upstream from the downstream.

As the blank moves from open to closed position, it separates the facing sleeves. The unique KLB sleeve assembly provides positive sealing action when the blank is closed and when the blank is open; the sleeves provide an unobstructed port and protect metal parts from the flowing media.

The design of the sleeves and body are such that no internal pressure or media is allowed to leak downstream even in the event of a downstream seal failure. Instead, the line pressure will vent to atmosphere, providing 100% isolation and protection.

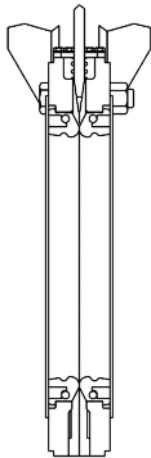

### Open position:

- Blank positioned above seals.
- Tight fit between sleeves contains internal pressure.
- No metal parts in contact with media.
- Unobstructed port area eliminates turbulence, minimizes pressure drop.
- No seat cavity where solids can collect and prevent full blank closure.

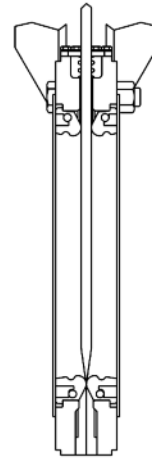

### Closed position:

- Blank travels completely through sleeves to provide blind flange shut-off.
- 100% Isolation-bubble tight shut-off results in absolutely zero downstream leakage, truly man-safe.
- Slots in body assure no downstream leakage, even if sleeves fail.
- Controlled stroke prevents gate from penetrating too far, minimizing stress on sleeve.

## Body Slots Confirm Blank Position

The KLB features multiple body slots that serve two purposes, visual confirmation of the blank position and as an egress point for the media. These egress points assure there is absolutely no opportunity for downstream leakage, providing a man-safe environment.



## Standard Configuration

- Ductile iron body housings.
- 2" to 16" 316 stainless steel blank rated for 150 psi, 18" to 24" rated for 90 psi.
- Universal body housing drilled and tapped to match ANSI B16.5 Class 150 companion flanges.
- High tear strength gum rubber sleeves with integral support rings.

## Optional

- Various gate materials:
  - 316L SS
  - 317L MN
  - 17-4 PH
  - Hastelloy® C-276
  - Feralium 255
  - 317L SS
  - Alloy 20
  - Jessop 700
  - Others
- 316 SS body housing (4" to 12")
- Sleeves (see page 3)
- Actuators (see page 4)
- Stem covers
- Control accessories
- Metric flange drilling

# Clarkson KLB Wafer Style Linear Line Blind

2" to 24"

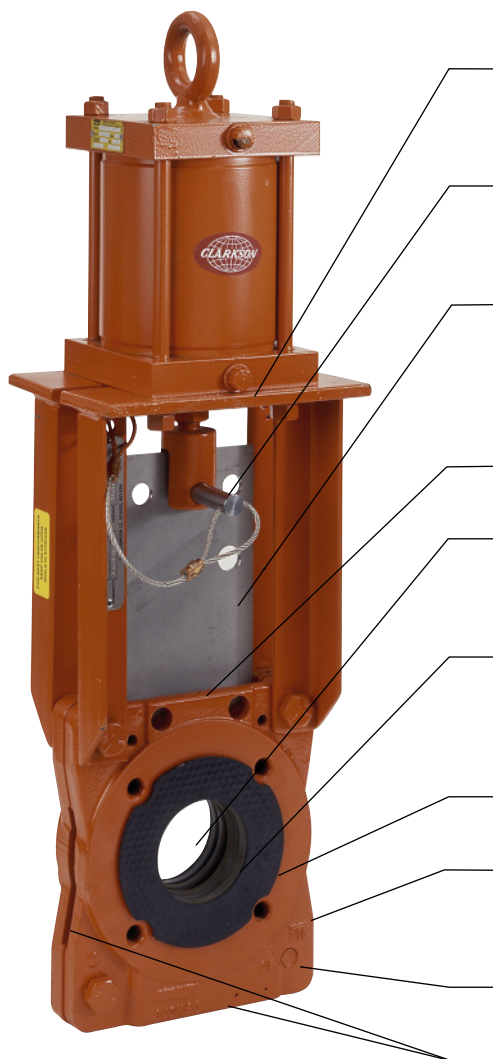

## Features

- Heavy-duty frame (yoke) designed to accept top removal stem nut, bevel gear or cylinder actuator without welding.
- Detachable pin removes potential energy from actuator lock-out pin prevents unwanted blind movement.
- The standard 316 stainless steel blank is completely withdrawn from the process flow in the open position and can be inspected or replaced without taking the line blind out of service.
- Patented, field replaceable elastomer sleeves.
- Unobstructed flow area, fully lined with elastomer sleeves, no metal to metal contact, no guides or wedges.
- Double sleeved design provides a "blind flange" shut-off when the gate is closed. Tight fit between sleeves contains internal pressure.
- No need for flange gaskets.
- Universal cast ductile full-flanged body housing to suit ANSI B16.5/150, PN10 or PN16 as required.
- Lockwashers used on all bolting.
- Body slots provide visual indication of blank position. Open bottom prevents build-up, allowing blank to fully close.

## Available Sleeve Materials

**Gum Rubber:** This category includes all natural gum elastomers, both filled and unfilled and synthetic Polyisoprene. Has high tensile strength, superior resistance to tear and abrasion and good resistance to heat build-up. Maximum continuous operating temperature 160°F.

**EPDM-HTP:** Advantages, excellent resistance to heat, ozone and sunlight, very good flexibility at low temperature, good resistance to alkalis, acids, and oxygenated solvents and superior resistance to water and steam. Limitations, poor resistance to oil, gasoline, and hydrocarbon based solvents. Maximum continuous operating temperature 300°F.

**Nitrile and Nitrile-HTP:** Advantages, very good resistance to petroleum based greases/oils, silicone greases/oils and nonoxidizing chemicals. Good resistance hydrocarbon based fuels. Limitations, inferior resistance to ozone and oxygenated solvents. Maximum continuous operating temperature 225°F for HTP and 200°F for standard Nitrile.

## Weights

Size	Manual	AC	HC
2	43	62	52
3	55	84	68
4	75	93	86
6	89	144	96
8	42	190	145
10	196	325	225
12	373	493	316
14	438	655	377
16	525	736	535
18	569	840	634
20	730	1163	751
24	1050	1613	1150

## Specifications

### Clarkson KLB Wafer Style Linear Line Blind

Wafer style, linear line blind shall be, packingless, rubber-lined, bi-directional assembly suitable for a wide range of industrial blanking applications. The full port design shall have no internal obstructions and will provide a man-safe shut-off when the blank is closed. The line blind's sealing surface is to be between two rubber sleeves that are compressed into the ductile iron body housings. The sleeve will be molded with an integral stiffener ring that locates the sleeve in the housing and helps the sleeves resist the high shearing forces present when the blank is driven between them. The stainless steel blank shall be completely withdrawn from the process flow when in the open position, and can be inspected and replaced, if necessary, without taking the line blind out of service. When the blank is in the closed position, the downstream sleeve can be replaced while the upstream portion of the line blind is still holding pressure. The body housing to be full flanged, universal type, standard drilled and tapped to suit ANSI B16.5/150 with optional PN10 or PN16 or others as required. The body housing shall have slots or openings to provide visual indication of the blank's position and allow any media to escape to atmosphere instead of downstream. The line blind is equipped with a heavy steel fabricated handwheel frame (yoke) which can be converted to bevel gear or cylinder operator in the field, complete with a 304 stainless steel rising stem and a dual-function lockout assembly that will isolate the blank from the potential energy of the actuator and prevent unwanted movement of the blank. All nonferrous exterior surfaces shall be painted to factory standard. Specify Clarkson KLB Wafer Style Linear Line Blind from Tyco Flow Control.

# Clarkson KLB Wafer Style Slurry Knife Gate Valve

2" to 24"

## Dimensions

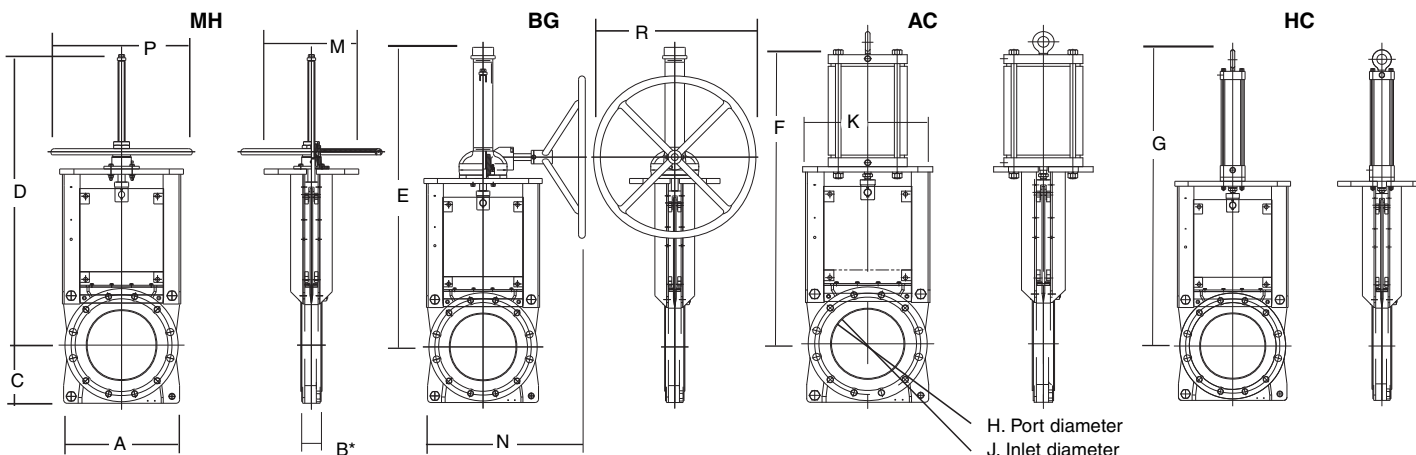

## Dimensions

Valve Size	A	B <sup>1</sup> *	B <sup>2</sup> *	C	D	E	F	G	H	J	K	L	N	P	R
2	6.90	2.25	2.13	4.00	19.17	22.18	21.29	22.04	1.85	2.00	7.50	5.25	15.13	12.00	12.00
3	8.00	2.44	2.25	4.88	22.35	24.09	24.70	25.20	2.81	3.00	8.75	6.39	15.75	12.00	12.00
4	9.60	2.44	2.25	4.69	24.45	25.16	26.27	27.27	3.81	4.00	10.50	6.91	16.63	12.00	12.00
6	11.00	2.68	2.50	5.75	29.45	33.02	31.63	32.51	5.80	6.00	12.63	9.13	17.68	16.00	12.00
8	13.50	3.19	3.00	7.03	34.94	36.39	37.00	37.88	7.73	8.00	14.75	10.31	18.75	20.00	12.00
10	16.40	3.25	3.00	8.23	41.07	44.30	43.91	44.79	9.74	10.00	17.50	13.38	23.87	20.00	24.00
12	19.00	3.50	3.25	9.75	-	47.52	50.13	50.76	11.73	12.00	20.38	13.45	29.06	-	24.00
14	21.00	3.50	3.25	10.77	-	52.79	53.90	54.03	12.96	13.25	22.55	14.75	30.15	-	24.00
16	23.75	4.00	3.75	11.88	-	56.53	59.07	59.20	15.00	15.25	24.47	14.75	31.11	-	24.00
18	25.50	4.06	3.76	12.13	-	66.17	68.05	68.42	17.00	17.25	26.32	17.00	30.26	-	24.00
20	28.00	5.13	4.76	14.50	-	71.79	73.97	74.10	19.03	19.25	28.06	18.88	31.13	-	24.00
24	33.00	5.19	4.76	16.50	-	85.13	87.25	88.00	23.21	23.45	35.00	18.88	34.60	-	24.00

Universal flanges drilled and tapped to ANSI B 16.5/150 or PN10 and PN16 or others, as required.

B<sup>1</sup> = minimum dimension required for installation.

B<sup>2</sup> = installed face-to-face.

## Actuation

Note: Not all actuators shown are available on all valve sizes.



MH Manual Handwheel

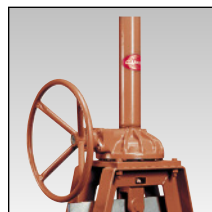

BG Manual Bevel Gear



AC Air Cylinder



HC Hydraulic Cylinder

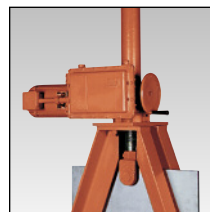

EM Electro-mechanical

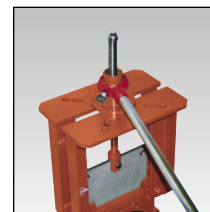

RA-Ratchet

Tyco Flow Control (TFC) provides the information herein in good faith but makes no representation as to its comprehensiveness or accuracy. This data sheet is intended only as a guide to TFC products and services. Individuals using this data sheet must exercise their independent judgment in evaluating product selection and determining product appropriateness for their particular purpose and system requirements. TFC MAKES NO REPRESENTATIONS OR WARRANTIES, EITHER EXPRESS OR IMPLIED, INCLUDING WITHOUT LIMITATION ANY WARRANTIES OF MERCHANTABILITY OR FITNESS FOR A PARTICULAR PURPOSE WITH RESPECT TO THE INFORMATION SET FORTH HEREIN OR THE PRODUCT(S) TO WHICH THE INFORMATION REFERS. ACCORDINGLY, TFC WILL NOT BE RESPONSIBLE FOR DAMAGES (OF ANY KIND OR NATURE, INCLUDING INCIDENTAL, DIRECT, INDIRECT, OR CONSEQUENTIAL DAMAGES) RESULTING FROM THE USE OF OR RELIANCE UPON THIS INFORMATION. Patents and Patents Pending in the U.S. and foreign countries. Tyco reserves the right to change product designs and specifications without notice. All registered trademarks are the property of their respective owners. Printed in the USA.