

## Before installation these instructions must be fully read and understood

### General

The intent of these instructions is to acquaint the user with the storage, installation and operation of this product.

This Safety Selector Valve (SSV) should only be used in accordance with the applicable operating instructions and within the application specifications of the purchase order.

### Storage and handling

Because cleanliness is essential to the satisfactory operation and tightness of an SSV, precautions should be taken during storage to keep out all foreign materials. Inlet and outlet protectors should remain in place until the valve is ready to be installed in the system. It is recommended that the valve be stored indoors in the original shipping container away from dirt and other forms of contamination.

The SSV should never be lifted or handled using the operator shaft.

When it is necessary to use a hoist, the chain or sling should be placed around the valve body or through the flange boltholes in a manner that will insure that the valve is in a vertical position to facilitate installation. Lifting eyes are provided for tandem units.

### Installation

Many valves are damaged when first placed in service because of failure to clean the connection properly when installed. Before installation, all flange faces or threaded connections on both the SSV and the connecting components (vessel, pipe or pressure relief valve) must be thoroughly cleaned of all dirt and foreign material.

Because foreign materials that pass into and through the safety selector valve can damage the seat, the systems on which the valves are tested and finally installed must also be inspected and cleaned. New systems in particular are prone to contain foreign objects that inadvertently get trapped during construction and will destroy the seating surface when the valve flows. The system should be thoroughly cleaned before the safety selector valve is installed.

The gaskets used must be dimensionally correct for the specific flanges. The inside diameters must fully clear the valve inlet and outlet openings so that the gasket does not restrict flow. For flanged valves, draw down all connection studs or bolts evenly to avoid possible distortion of the valve body.

The SSV's are shipped from the factory with one side completely "isolated" and one side "active". The position indicator points to the "active" side. Check that the "active" side is correct for the initial installation and start-up operation. See OPERATION below for instructions to change. The SSV is designed to minimize inlet pressure loss to a pressure relief valve. To assure this is accomplished follow these guidelines:

- Connect the SSV as direct and close as possible to the vessel being protected.
- The SSV should be mounted vertically in an upright position either directly on a nozzle from the pressure vessel or on a short connection fitting that provides a direct, unobstructed flow between the vessel and the valve.
- The SSV should never be installed on a fitting having a smaller inside diameter than the inlet connection of the SSV.

The weight of the discharge piping should be carried by a separate support and be properly braced to withstand reactive thrust forces when the pressure relief valve relieves. The SSV should also be supported to withstand any swaying or system vibrations.

### Tandem installation

The SSV tandem assembly consists of an inlet SSV, two pressure relief valves, an outlet SSV and a mechanically coupled switch over linkage. Tandem units can be assembled at the factory or on site by the customer. For on site assembly see drawings provided with the SSVs for correct orientation of the pressure relief valves, the inlet and outlet safety selector valves and the tandem assembly linkage. The inlet SSV nameplate should face away from the outlet SSV and the outlet SSV nameplate should face up.

Before installing the linkage assure that the position indicators on both the inlet and outlet SSV are pointing to the same pressure relief valve.

### Operation

#### Single active

The Single Active SSV is a device for diverting the process connection from one pressure relief valve to another during static conditions. Do not attempt to change over during a pressure relief event.

Refer to Figures 1 and 2 and follow these steps:

1. Remove lock.
2. Make sure both bleed ports are closed.
3. Turn 1 1/2" hex retraction bushing clockwise (downward) to stop.
4. Rotate 1 1/2" hex red position indicator bushing 180° to stop. Maximum torque should not exceed 25 Ft-Lb. Refer to View "A-A" of Figures 1 and 2.

5. Turn 1 1/2" hex retraction bushing counter-clockwise (upward) to stop. Maximum torque should not exceed 80 ft lb.
6. Open bleed port on neck opposite red position indicator to vent isolated side.
7. Leave bleed port on isolated side open.
8. Reinstall lock.

#### Dual active

The Dual Active SSV allows two pressure relief valves to be connected to the process simultaneously. It can also be operated to isolate either pressure relief valve when necessary. Do not attempt to change over during a pressure relief event.

Refer to Figure 3 and follow these steps:

1. Remove lock
2. Make sure both bleed ports are closed
3. Turn 1 1/2" hex retraction bushing clockwise (downward) to stop.
4. Pull detent spring to clear indicator groove and rotate 9/16" hex to desired position. Max torque 25ft/lb. Refer to View "A-A" of Figure 3.
5. Turn 1 1/2" hex retraction bushing counter-clockwise (upward) to stop. Max torque should not exceed 80 ft/lb.
6. If in Single Active position, open bleed port on neck opposite position indicator to vent isolated side.
7. Leave bleed port on isolated side open.
8. Reinstall lock.

# Installation and Operational Safety Instructions

## Safety Selector Valves

### Operation: tandem assembly for single or dual active

The SSV tandem assembly consists of an inlet SSV, two PRV's, an outlet SSV and a mechanically coupled switch-over linkage. Operation is similar to the individual SSV except both inlet and outlet SSVs must be switched. Perform steps 1, 2 and 3 on the inlet SSV first then on the outlet SSV. Perform step 4 on one valve only (inlet or outlet SSV). The linkage should simultaneously switch both valves. If required, manually assist the other valve to complete the desired rotation (180° for Single Active and 90° or 180° for Dual Active). Perform steps 5 through 8 on the inlet SSV first then the outlet SSV.

### Safety precautions

- Never attempt to operate the SSV during a pressure relieving event.
- The bleed valve should be piped or vented to a safe location.
- Always wear proper safety gear to protect head, eyes, ears, etc. anytime you are near pressurized valves.
- Never attempt to remove the SSV from a system that is pressurized.
- Maintenance should be performed on a regular basis. The interval between inspection and maintenance will depend on service conditions and frequency of operation.
- For further information including adjustment, maintenance, cleaning and detail illustrations, obtain the appropriate Operation and Maintenance Manual from the following table. These manuals may be requested from the factory or are available at [www.tycovalves.com](http://www.tycovalves.com).

Valve Model	Operation and Maintenance Manual
Single Active SSV	05.9040.159
Dual Active SSV	05.9040.152

Service Technicians are available to assist with your installation or other field problems. Call your nearest Tyco Valves and Controls representative.

### WARNING

- Attempts to adjust and/or repair this product by unauthorized or unqualified persons void the product warranty and may cause damage to equipment and serious injury or death to persons.
- This product is a safety related component intended for use in critical applications. The improper application, installation or maintenance of the valve or the use of parts or components not manufactured by Tyco Valves & Controls may result in a failure of the valve.
- Any installation, maintenance, adjustment, repair or test, performed on the safety selector valve must be done in accordance with the requirements of all applicable Tyco Valves & Controls Procedures and Instructions as well as applicable National and International Codes and Standards.
- The information, specifications and technical data (the "Specifications") contained in this document are subject to change without notice. Tyco Valves & Controls does not warrant that the Specifications are current and assumes no responsibility for the use or misuse thereof. The Purchaser should verify that there have been no changes to the Specifications prior to use.
- For tandem units, the position indicators on both the inlet and outlet SSV must point to the same pressure relief valve.

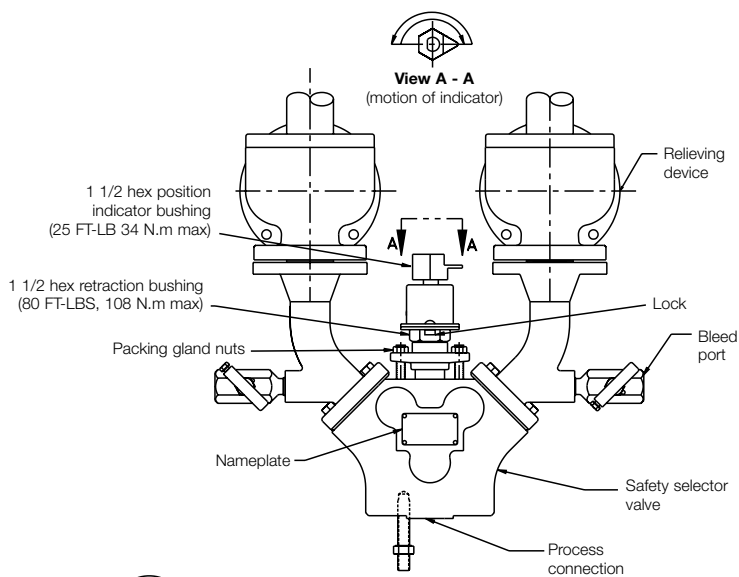

**Figure 1**  
1" 150# thru 600#

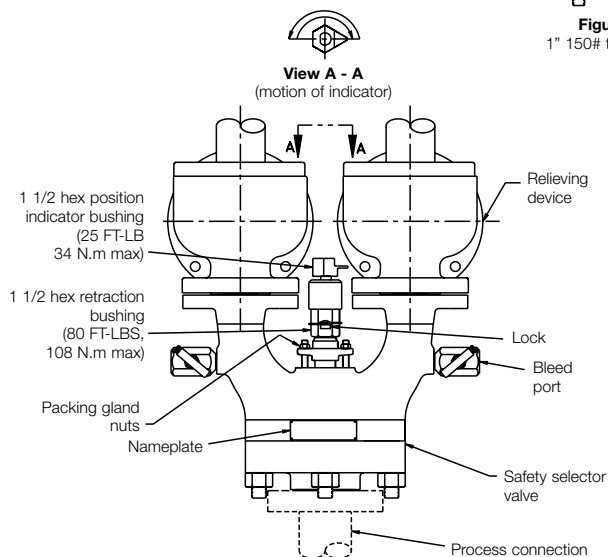

**Figure 2**  
1" 900# - 2500# & 1.5" - 8" all

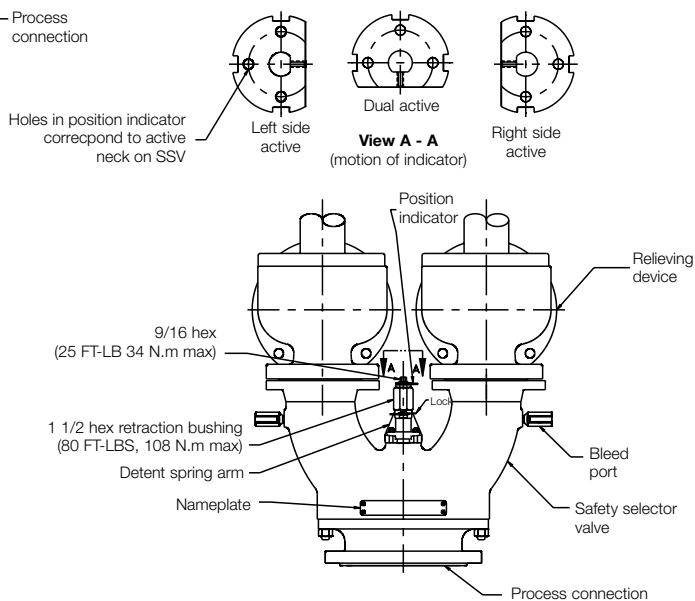

**Figure 3**  
Dual active 1.5" - 10" all