

ENGINEERING DOC. NO. 25.1618.017

TITLE **INSTALLATION, OPERATION & MAINTENANCE INSTRUCTIONS -  
HD SERIES MONOFLANGES**

Revision	0						
Prepared By	M. Watchman						
Approved By							
Date	28/10/99						

**INSTALLATION, OPERATION & MAINTENANCE  
INSTRUCTIONS  
HD SERIES MONOFLANGES**

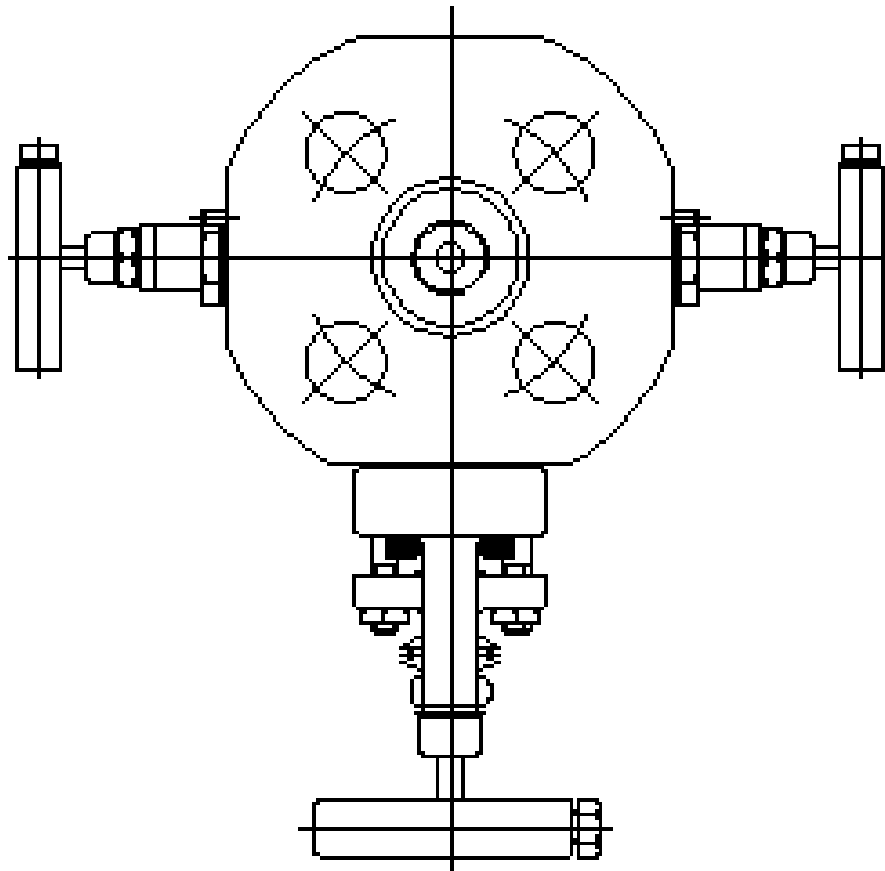

ENGINEERING DOC. NO.                      25.1618.017

TITLE    **INSTALLATION, OPERATION & MAINTENANCE INSTRUCTIONS -  
HD SERIES MONOFLANGES**

Revision	0						
Prepared By	M. Watchman						
Approved By							
Date	28/10/99						

**1.0 INTRODUCTION**

The monoflange range of valves are of a forged material with integral metal seats. Teflon or graphite packing materials are used with a variety of end connections to suit each application. For maximum pressure / temperature ratings see applicable valve assembly drawing.

**2.0 INSTALLATION**

- 2.1 To increase the probability of trouble free service, ensure that proper care and attention is taken during the installation process.
- 2.2 Unpack the monoflange and check the tag, nameplate or body stamping for correct part / identification number.
- 2.3 Check the monoflange tag nameplate for flow direction to ensure correct installation. If the valve schematic is not shown on the valve body, refer back to the relevant general assembly drawing.
- 2.4 Immediately prior to valve installation check the piping to which the valve is to be connected to, for cleanliness and freedom from foreign materials.
- 2.5 Threaded Valve Installation.  
  
Pipe or fitting connections must be made up tight. Threaded pipe joints depend on a good intimate fit between the male and female pipe threads usually with the use of a thread tape or sealant.
  - 2.5.1 Check the threads on both the valve and the mating pipe for both form and cleanliness.
  - 2.5.2 Do not use substantial wrenching force on a tapered pipe joint until it is apparent that threads are properly engaged. Taper pipe threads are inherently loose fit at entry.
- 2.6 Welding Joint Valve Installation

ENGINEERING DOC. NO.                      25.1618.017

TITLE    **INSTALLATION, OPERATION & MAINTENANCE INSTRUCTIONS -  
HD SERIES MONOFLANGE**

Revision	0						
Prepared By	M. Watchman						
Approved By							
Date	28/10/99						

Welding joints properly made provide a structure and metallurgical continuity between the pipe and the valve. All welding should be in accordance with the appropriate installation code.

2.7 Flanged Joint Valve Installation.

Prior to assembly, mating flanges should be checked to ensure correct size and rating. Flanges should be assembled using correct gasket or seal ring and bolting as specified in ANSI B16-5.

**3.0 OPERATION**

Monoflanges which have been matched to a typical service application and properly installed in its piping system can be expected to have a long service life with a minimum of attention. However, valves have moving and wearing parts and depends on long term preservation of highly finished surfaces on certain working parts for satisfactory performance.

3.1 The handle of the valve has been designed to provide an adequate force to operate the valve with the maximum pressure differential across it. The use of an additional mechanical device to operate the valve is not recommended as this may result in damage to the valve.

**4.0 MONOFLANGE MAINTENANCE**

Valves which remain in one position for long periods of time may be subject to some degree of inoperability due to the loss of effective lubricants in threads, ageing of seats and seals, surface corrosion of moving parts or accumulation of harmful solids. In some applications it may be desirable to schedule periodic, partial or full cycle exercising of the valves.

4.1 Stem seal leakage usually results from seal wear, and can usually be corrected by tightening the bonnet bushing. Overtightening can cause high stem friction, accelerated wear and shortened stem seal life.

4.2 If stem replacement is needed, safe practice requires depressurising the valve before removal of the bonnet bushing. Use of backseat to permit repacking under pressure is to be considered unsafe.

4.3 STEM SEAL REPLACEMENT

ENGINEERING DOC. NO.                      25.1618.017

TITLE    **INSTALLATION, OPERATION & MAINTENANCE INSTRUCTIONS -  
HD SERIES MONOFLANGES**

Revision	0						
Prepared By	M. Watchman						
Approved By							
Date	28/10/99						

Teflon packings do not often need replacement. If leakage occurs usually the leak can be stopped by tightening the bonnet bushing.

- 4.3.1 A reference to Fig. 1 for Teflon packed bonnet parts.
- 4.3.2 Remove bonnet lock pin from body using heavy duty pliers or wire cutters.
- 4.3.3 Unscrew bonnet counter clockwise and remove from valve body.
- 4.3.4 Place bonnet in soft jawed vice to facilitate disassembly.
- 4.3.5 Remove handle (item 9) by loosening handle bolt.
- 4.3.6 Remove dust cap (item 8) from upper portion of gland follower (item 6).
- 4.3.7. Loosen locknut (item 7) and unscrew bushing off stem and out of bonnet.
- 4.3.8 Remove stem (item 3) from bonnet (item 2) by pushing it downward.
- 4.3.9 Remove gland packing (item 5) from the bonnet.
- 4.3.10 Clean all bonnet assembly parts with acetone or alcohol.
- 4.3.11 Inspection all parts for damage, particularly the stem threads and ball end. Replace both the stem and the gland follower if they do not engage smoothly.
- 4.3.12 Lubricate the stem threads with the appropriate lubricant specified on the assembly drawing.
- 4.3.13 Insert the stem (item 3) threaded end first, into the bonnet (item 2) that is threaded externally.
- 4.3.14 Push stem upwards from the bottom of the bonnet.

ENGINEERING DOC. NO. 25.1618.017

**TITLE INSTALLATION, OPERATION & MAINTENANCE INSTRUCTIONS -  
HD SERIES MONOFLANGES**

Revision	0						
Prepared By	M. Watchman						
Approved By							
Date	28/10/99						

- 4.3.15 Place the gland packing (item 5) over the threaded end of the stem and push it down into the body of the bonnet.
- 4.3.16 Lubricate the gland follower (item 6) threads with the appropriate lubricant.
- 4.3.17 Place the gland follower with locknut over the stem and start the threads for both the bonnet and stem by hand. Screw the gland follower down into the bonnet until it reaches the stem seal.
- 4.3.18 Place the dust cap (item 8) over the upper portion of the valve stem.
- 4.3.19 Place the handle assembly (item 9) onto the upper portion of the stem and tighten handle bolt to 12 inch/lbs. Be careful not to bend the stem.

**NOTE:**

Assembly area and tooling should be clean to prevent the ingress of dirt into the valve.

4.4 Valve Assembly

- 4.4.1 Lightly lubricate the bonnet threads with the appropriate lubricant.
- 4.4.2 Place o-ring over bonnet and butt up next to shoulder.
- 4.4.3 Place bonnet assembly into the seat cavity and screw the bonnet into the valve by hand.
- 4.4.4 Tighten the bonnet to the proper torque value shown below using the preset torque wrench.

Stainless steel (120lb/ft)

- 4.4.5 Tighten the gland follower using a wrench. This should be tightened snugly but not over tightened. Check the gland follower tightness by turning the handle. If it feels too loose, you may tighten the gland follower more. If it feels too tight, the stem seal must be replaced and

the gland follower re-tightened.



Flow Control

**Anderson Greenwood  
Instrumentation Products**

ENGINEERING DOC. NO. 25.1618.017

TITLE **INSTALLATION, OPERATION & MAINTENANCE INSTRUCTIONS -  
HD SERIES MONOFLANGES**

<u>Revision</u>	0						
<u>Prepared By</u>	M. Watchman						
<u>Approved By</u>							
<u>Date</u>	28/10/99						

4.4.6 The gland follower tightness is a matter of both judgement and experience. The basic considerations are:-

Too loose – the bonnet will leak.

Too tight – the handle will be hard to turn and the steam seal may be damaged.

4.4.7 Once the gland follower is properly adjusted, tighten the locknut (item 7) to lock the bushing in place.

4.4.8 Tap one bonnet lock pin into one of the two holes that one of the flats on the bonnet hex centres over.

HEAD UNIT ASSEMBLY H.D. TEFLON

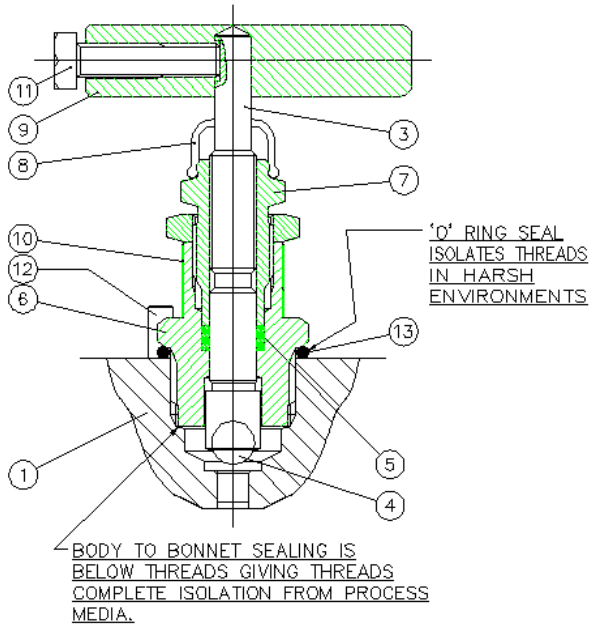

ITEM	DESCRIPTION	MATERIAL
1	BODY	
2	BONNET	
3	STEM	
4	SWIVEL BALL	
5	GLAND PACKING	PTFE
6	GLAND FOLLOWER	
7	LOCKNUT	
8	DUST CAP	
9	HANDLE	
10	RING LABEL	304S15
11	T-BAR BOLT	
12	LOCKING PIN	
13	O-RING	BUNA



Flow Control

**Anderson Greenwood  
Instrumentation Products**

ENGINEERING DOC. NO. 25.1618.017

TITLE **INSTALLATION, OPERATION & MAINTENANCE INSTRUCTIONS -  
HD SERIES MONOFLANGES**

Revision	0						
Prepared By	M. Watchman						
Approved By							
Date	28/10/99						

4.5 Monoflanges with OS+Y Bonnet Assemblies.

4.5.1 The same care should be exercised with OS+Y bonnet assemblies regarding installation and operating procedures, as the HD type (section 2).

4.6 Valve Maintenance

If stem packing replacement is needed safe practice requires depressurising the valve before removal of the bonnet.

4.6.1 Remove bonnet screws (item 3)

- 4.6.2 Remove bonnet assembly from valve body making sure the bonnet gasket does not become torn or separated. If the gasket does become torn or separated it must be replaced.
- 4.6.3 Remove handle assembly (item 1) by loosening handle bolt.
- 4.6.4 Remove dust boot (item 12) from bonnet yoke (item 4).
- 4.6.5 Remove stem (item 5) by screwing it downward.
- 4.6.6 Remove bellows (item 11).
- 4.6.7 Remove packing nuts (item 9) and packing bolt (item 8).
- 4.6.8 Remove gland flange (item 10) and follower (item 7).
- 4.6.9 Remove packing (item 6).
- 4.6.10 Clean all bonnet parts with acetone or alcohol.
- 4.6.11 Inspect parts for damage, particularly the stem threads and ball end. Replace both stem and yoke if threads do not engage smoothly.



Flow Control

**Anderson Greenwood  
Instrumentation Products**

ENGINEERING DOC. NO.                      25.1618.017

TITLE    **INSTALLATION, OPERATION & MAINTENANCE INSTRUCTIONS -  
HD SERIES MONOFLANGES**

<u>Revision</u>	0						
<u>Prepared By</u>	M. Watchman						
<u>Approved By</u>							
<u>Date</u>	28/10/99						

- 4.6.12 Coat graphoil packing (item 6) with castor oil. DO NOT soak packing in the castor oil. DO NOT coat teflon.
- 4.6.13 Place the new packing into the packing bore in the yoke (item 4) as shown in the figure.
- 4.6.14 Place the follower (item 7) on top of the packing with the end that is radiused up as shown.
- 4.6.15 Place the gland flange (item 10) top of the follower with the side that has a boss on it up as shown.

- 4.6.16 Install the bellows (item 11) between the yoke and gland flange as shown. Make sure that the bellows fit over the bosses on the yoke and the gland flanges.
  - 4.6.17 Apply the lubricant uniformly over the entire threaded part of the stem (item 5).
  - 4.6.18 Install the stem through the bottom of the yoke as shown. Screw the stem all the way into the yoke.
  - 4.6.19 Install the packing bolts (item 8) through the bottom of the yoke and gland flange as shown. Make sure that the bolt head goes into the hex recess found on the bottom of the yoke.
  - 4.6.20 Install the packing nuts (item 12) onto the packing bolts and screw them down, hand tight only, until they make contact with the gland flange. Make sure that the gland flange is approximately parallel to the bottom of the yoke after the nuts are in position.
- Final tightening of the packing nuts will be done after the complete bonnet assembly is placed on the valve.
- 4.6.21 Place a small amount of lubricant on the stem threads that are sticking out of the top of the yoke.
  - 4.6.22 Install the boot (item 12) over the top of the stem as shown, and push down into the boss located on the top of the yoke.



Flow Control

**Anderson Greenwood  
Instrumentation Products**

ENGINEERING DOC. NO. 25.1618.017

TITLE **INSTALLATION, OPERATION & MAINTENANCE INSTRUCTIONS -  
HD SERIES MONOFLANGES**

<u>Revision</u>	0						
<u>Prepared By</u>	M. Watchman						
<u>Approved By</u>							
<u>Date</u>	28/10/99						

- 4.6.23 Install the handle assembly (item 1) onto the top of the stem as shown. Tighten the handle bolt to 25 inch/lbs torque. Make sure the handle bolt comes in contact with the flat area on the side.
- 4.6.24 Install bonnet assembly and bonnet screws. Torque bonnet screws to 7-10 lbs/ft.
- 4.6.25 Turn handle to open and close the valve. Check for binding, rubbing or any resistance to smooth operation.

OS+Y GRAPHITE PACKED BONNET ASSEMBLY

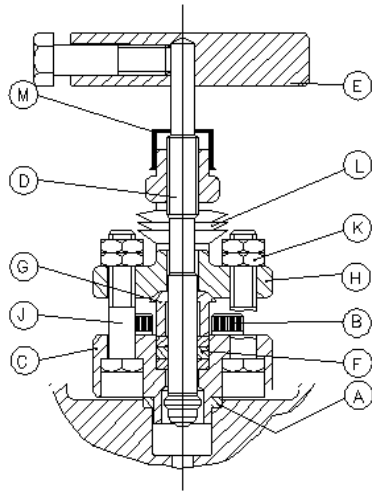

OS & Y ASSEMBLY			
ITEM	DESCRIPTION	MATERIAL	QTY
A	SEAL	GRAPHITE	1
B	SCREW SOC. HEAD 1/4"-28x1"	ASTM A574 ZN/CO	4
C	YOEK	ASTM A351-77-CF8M	1
D	STEM ASSEMBLY	316 SS	1
E	HANDLE ASSEMBLY	ASTM A582-303	1
F	PACKING OS & Y	GRAPHITE	3
G	FOLLOWER	B7B3 SST 316	2
H	GLAND FLANGE	ASTM A351-77-CF8M	1
J	BOLT 5/16" -18x1.5 HEX. CAP	SST 18-8	2
K	NUT 5/16" -18 HEX. WSHR FACE	SST 18-8	4
L	BELLOWS	SANTOPRENE	1
M	BOOT	POLYPROPYLENE	1



Flow Control

**Anderson Greenwood  
Instrumentation Products**

PAGE 10 OF 14

ENGINEERING DOC. NO. 25.1618.017

TITLE **INSTALLATION, OPERATION & MAINTENANCE INSTRUCTIONS -  
HD SERIES MONOFLANGES**

<u>Revision</u>	0						
<u>Prepared By</u>	M. Watchman						
<u>Approved By</u>							
<u>Date</u>	28/10/99						

**5.0 HIGH TEMPERATURE HD SERIES BONNET ASSEMBLIES**

For installation and operating procedures see Section 2.0

Valves which remain in one position for long periods of time may be subject to some degree of operability due to the loss of effective lubricants in threads, ageing of packing, surface corrosion of moving parts or accumulation of harmful solids. In some applications it may be desirable to schedule periodic partial or full cycle exercising of these valves.

Stem seal leakage usually results from seal wear and can usually be corrected by tightening the bonnet bushing. Over-tightening can cause high stem friction, accelerated wear and shortened stem seal life.

If stem seal replacement is needed, safe practice requires depressurising the valve before removal of the bonnet bushing. Use of back seat to permit repacking under pressure should be considered unsafe.

#### 5.1 Stem Seal Replacement

Graphite packings do not often need replacement if leakage occurs, usually the leak can be stopped by tightening the bonnet bushing.

5.1.1 Refer to figure 3, High Temperature bonnet assembly for part identification.

5.1.2 Remove bonnet lock pin from valve body using heavy duty pliers or wire cutters.

5.1.3 Unscrew bonnet counter-clockwise to remove bonnet assembly from valve body.

5.1.4 Place bonnet assembly in soft jaw vice to facilitate disassembly.

5.1.5 Remove handle (item I) by loosening handle bot.

5.1.6 Loosen lock nut (item G) and unscrew bushing off stem (item B) and out of bonnet (item A).

5.1.7 Remove stem (item B) from bonnet (item A) by pushing it downwards.



Flow Control

**Anderson Greenwood  
Instrumentation Products**

ENGINEERING DOC. NO.                      25.1618.017

TITLE    **INSTALLATION, OPERATION & MAINTENANCE INSTRUCTIONS -  
HD SERIES MONOFLANGES**

<u>Revision</u>	0						
<u>Prepared By</u>	M. Watchman						
<u>Approved By</u>							
<u>Date</u>	28/10/99						

5.1.8 Remove Top extrusion ring (item E), Gland Packing (item D) and Bottom extrusion ring (item C) from bonnet.

- 5.1.9 Clean all bonnet assembly parts with acetone or alcohol.
- 5.1.10 Inspect parts for damage, particularly the stem threads and ball end. Replace both stem (item B) and gland follower (item F) if threads do not engage smoothly.
- 5.1.11 Lubricate the stem threads with the appropriate lubricant.
- 5.1.12 Insert the stem (item B) threaded end first, into the end bonnet (item A).
- 5.1.13 Push stem upward from the bottom of the bonnet.
- 5.1.14 Insert the bottom extrusion ring (item C) into the bonnet ensuring that chamfer is face down.
- 5.1.15 Place the gland packing (item D) over the threaded end of the stem and push it down into the body of the bonnet.
- 5.1.16 Insert the top extrusion ring (item E) onto the top of the gland packing.
- 5.1.17 Lubricate the gland follower (item F) threads with the appropriate lubricant.
- 5.1.18 Refit label (item H).
- 5.1.19 Place the gland follower with locknut (items F & G) over the stem and start the threads for both the stem and bonnet by hand. Screw the gland follower down into the body until it reaches to top extrusion ring.
- 5.1.20 Place the handle assembly (item I) onto the upper portion of the stem and tighten the handle bolt to 12 inch/lbs.

5.2 Valve Assembly



**Anderson Greenwood  
Instrumentation Products**

ENGINEERING DOC. NO. 25.1618.017

TITLE **INSTALLATION, OPERATION & MAINTENANCE INSTRUCTIONS -  
HD SERIES MONOFLANGES**

<u>Revision</u>	0						
<u>Prepared By</u>	M. Watchman						
<u>Approved By</u>							
<u>Date</u>	28/10/99						

- 5.2.1 Lightly lubricate the bonnet threads with the appropriate lubricant.

- 5.2.2 Place 'O' ring (item J) over bonnet thread and butt upto next shoulder.
- 5.2.3 Place bonnet assembly into the seat cavity and screw the bonnet into the valve body by hand.
- 5.2.4 Tighten the bonnet to the proper torque value shown below using a preset torque wrench.

HD SERIES STAINLESS STEEL – 120 ft / lbs

5.2.5 Tighten the gland follower (item F) using a wrench. This should be tightened snugly but not over tightened. Check the gland follower tightness by turning the handle (item I). If it feels loose you may tighten the gland follower more. If it feels too tight, the stem seal must be replaced and the gland follower re-tightened.

5.2.6 The gland follower tightness is a matter of both judgement and experience. The basic considerations are:-

Too Loose - The bonnet will leak.

Too Tight - The handle will be hard to turn and the stem seal may be damaged.

5.2.7 Once the gland follower (item F) is correctly adjusted, tighten locknut (item G) to lock the bushing in place.



Flow Control

**Anderson Greenwood  
Instrumentation Products**

ENGINEERING DOC. NO. 25.1618.017

TITLE **INSTALLATION, OPERATION & MAINTENANCE INSTRUCTIONS -  
HD SERIES MONOFLANGES**

<u>Revision</u>	0						
<u>Prepared By</u>	M. Watchman						
<u>Approved By</u>							
<u>Date</u>	28/10/99						

HEAD UNIT ASSEMBLY H.D GRAPHITE

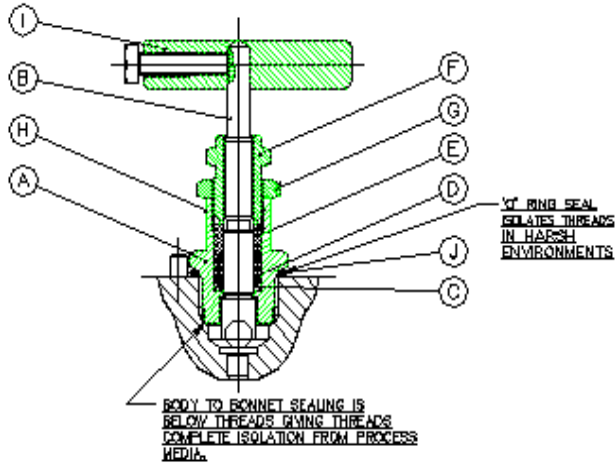

J	O RING SEAL	BUNA N	1
I	T-BAR HANDLE ASSY	303S21	1
H	RING LABEL	S.S.	1
G	LOCKNUT	303S21	1
F	GLAND FOLLOWER	303S21	1
E	TOP EXTRUSION RING	316 S.S.	1
D	GLAND PACKING	GRAPHITE	1
C	BOTTOM EXTRUSION RING	316 S.S.	1
B	STEM ASSEMBLY	316 S.S.	1
A	BONNET	316 S.S.	1
ITEM	DESCRIPTION	MATERIAL	QTY PER
HEAD UNIT ASSEMBLY HD GRAPHITE (T-BAR)			