

# KEYSTONE

**Anderson, Greenwood & Co.**  
A Subsidiary of Keystone International, Inc.

DWN	R. Virgil	1-29-85	INSTALLATION, OPERATION AND MAINTENANCE INSTRUCTION FOR H7K and M5K COMMERCIAL VALVES		
CHK	R. Dalton	1-30-85			
ENGR	J. Spahr	2-05-85			
PROD	R. Krisik	2-05-85			
APPR	C. Smith	2-05-85	Size A	05.9040.133	Rev B
QA			PAGE 1 OF 8		

REVISIONS

SYM	PAGE	DESCRIPTION	DWN	CHK	RC	APPROVAL
A		ECR #89-108-05	<i>A. Wilke</i> 4-25-89	<i>R. Virgil</i> 4/26/89		<i>J.A. Conley</i> 4/26/89 <i>J.W. [unclear]</i> 4/26/89 <i>J. Z. [unclear]</i> 4/24/89
B		ECR #93-068-05 Revise entire report	<i>J. Smith</i> 3-22-93	<i>R. Virgil</i> 4/28/93		<i>J.A. Conley</i> 4/28/93 <i>J.W. [unclear]</i> 5/10/93

## INSTALLATION, OPERATION AND MAINTENANCE INSTRUCTIONS FOR H7K AND M5K VALVES

1.0 INTRODUCTION

Anderson Greenwood and Co., H7K, and M5K valves feature OS & Y bonnets, hard integral or insert seat options and are supplied with a .187 dia. orifice.

2.0 INSTALLATION

2.1 Check hand valve body for flow arrow proper flow orientation.

2.2 For all field welds of pipe or tube to valves, it is recommended that the valve seat be in the partially open position during welding.

2.3 Immediately prior to valve installation, check the piping to which the valve is to be connected for cleanliness and freedom from foreign materials.

2.4 THREADED VALVE INSTALLATION

Threaded pipe joints depend on a good intimate fit between the male and female pipe threads, therefore the use of a thread sealant is recommended and the pipe fitting connections must be made up tight.

2.5 WELD JOINT VALVE INSTALLATION

Welded joints, properly made, provide a structural and metallurgical continuity between the pipe and the valve body. All welding should be in accordance with any Code or jurisdictional regulations applicable to the piping system construction and with complete and approved welding procedures.

Heat input should be kept to a minimum by controlling the amperage and voltage to the lowest practical levels. A minimum travel speed or three (3) I.P.M. should be maintained and the interpass temperature should not exceed 200°F. The process employed should be GTAW with argon gas and a maximum diameter weld rod of 1/8".

### 3.0 OPERATION

Valves which have been reasonably matched to a typical valve service application and properly installed in its piping system can expect to have a long service life with a minimum of attention. However, these valves have moving and wearing parts and depend on term preservation of highly finished surfaces on these parts for satisfactory valve performance.

3.1 The use of a "cheater" to operate the valve handle is not necessary and not recommended. This practice can cause valve damage.

3.2 All valves have rising stems with right hand thread. Rotate the handle counter-clockwise to open and clockwise to close.

3.3 Bonnets with rising stems are provided with a backseat. Backseats in rising stem bonnets should be considered basically as stops to prevent overtravel when opening valves. It is recommended not to leave the upper stem in the backseated position. Note MSS SP-92, "MSS Valve User Guide", paragraph 4.3.

### 4.0 VALVE MAINTENANCE

The important performance parameters are pressure boundary integrity, actuating force required and internal leak tightness. Maintenance should logically address the importance of preserving the performance parameters.

Valves which remain in one position for long periods of time may be subject to some loss of operability due to the loss of effective lubricants in threads, aging of packing, surface corrosion of moving parts or accumulation of harmful solids. In some applications it may be desirable to schedule periodic partial or full cycle exercising of these valves.

Stem seal leakage usually results from packing wear and can usually be corrected by tightening the packing nuts. Over tightening can cause high stem friction, accelerated wear and shortened packing life.

#### 4.1 Stem Seal Replacement

If stem packing replacement is needed, safe practice requires depressurizing the valve before removal of the bonnet.

Refer to Figure 1 for part identification.

- 4.1.1 Remove bonnet screws (item 3).
- 4.1.2 Remove bonnet assembly from valve body making sure the bonnet gasket does not become torn or separated. If the gasket does get torn or separated it must be replaced.
- 4.1.3 Remove handle assembly (item 1) by loosening handle bolt.
- 4.1.4 Remove dust boot (item 12) from bonnet yoke (item 4).
- 4.1.5 Remove stem (item 5) by screwing it downward.
- 4.1.6 Remove bellows (item 11).
- 4.1.7 Remove packing nuts (item 9) and packing bolts (item 8).
- 4.1.8 Remove gland flange (item 10) and follower (item 7).
- 4.1.9 Remove packing (item 6).
- 4.1.10 Clean all bonnet parts with acetone or alcohol.
- 4.1.11 Inspect parts for damage, particularly the stem threads and BALL end. Replace both stem and yoke if threads do not engage smoothly.
- 4.1.12 Coat grafoil packing (item 6) with castor oil. **DO NOT** soak packing in the castor oil. **DO NOT** coat teflon.
- 4.1.13 Place the new packing into the packing bore in the yoke (item 4) as shown in the figure.
- 4.1.14 Place the follower (item 7) on top of the packing with the end that is spherical up as shown.
- 4.1.15 Place the gland flange (item 10) top of the follower with the side that has a boss on it up as shown.
- 4.1.16 Install the bellows (item 11) between the yoke and gland flange as shown. Make sure that the bellows fit over the bosses on the yoke and gland flange.
- 4.1.17 Apply the lubricant uniformly over the entire threaded part of the stem (item 5).

- 4.1.18 Install the stem through the bottom of the yoke as shown. Screw the stem all the way into the yoke.
- 4.1.19 Install the packing bolts (item 8) through the bottom of yoke and gland flange as shown. Make sure that the bolt head goes into the hex recess found on the bottom of the yoke.
- 4.1.20 Install the packing nuts (item 9) onto the packing bolts and screw them down, hand tight only, until they make contact with the gland flange. Make sure that the gland flange is approximately parallel to the bottom of the yoke after the nuts are in position.

Final tightening of the packing nuts will be done after the complete bonnet assembly is placed on the valve.

- 4.1.21 Place a small amount of the lubricant on the stem threads that are sticking out of the top of the yoke.
- 4.1.22 Install the boot (item 12) over the top of the stem as shown. And push down onto the boss located on the top of the yoke.
- 4.1.23 Install the handle assembly (item 1) onto the top of the stem as shown. Tighten the handle bolt to 25 in-lbs torque. Make sure that the handle bolt comes in contact with the flat area on the side of the stem when it is tightened.
- 4.1.24 Install bonnet assembly and bonnet screws. Torque bonnet screws 7 to 10 ft-lbs.
- 4.1.25 Tighten the packing nuts. The amount of tightening is a matter of judgement and experience. The basic considerations are:

Too Loose- The bonnet will leak.

Too tight - The handle will be hard to turn and the stem seal may be ruined.

Make sure that after the packing nuts are tightened that the gland flange is still approximately parallel to the bottom of the yoke.

Additional adjustment may be required to stop stem seal leakage when the valve is placed under pressure.

5.0 POST ASSEMBLY INSPECTION

Turn the handle to open and close the valve. Check for binding, rubbing or any resistance to smooth operation.

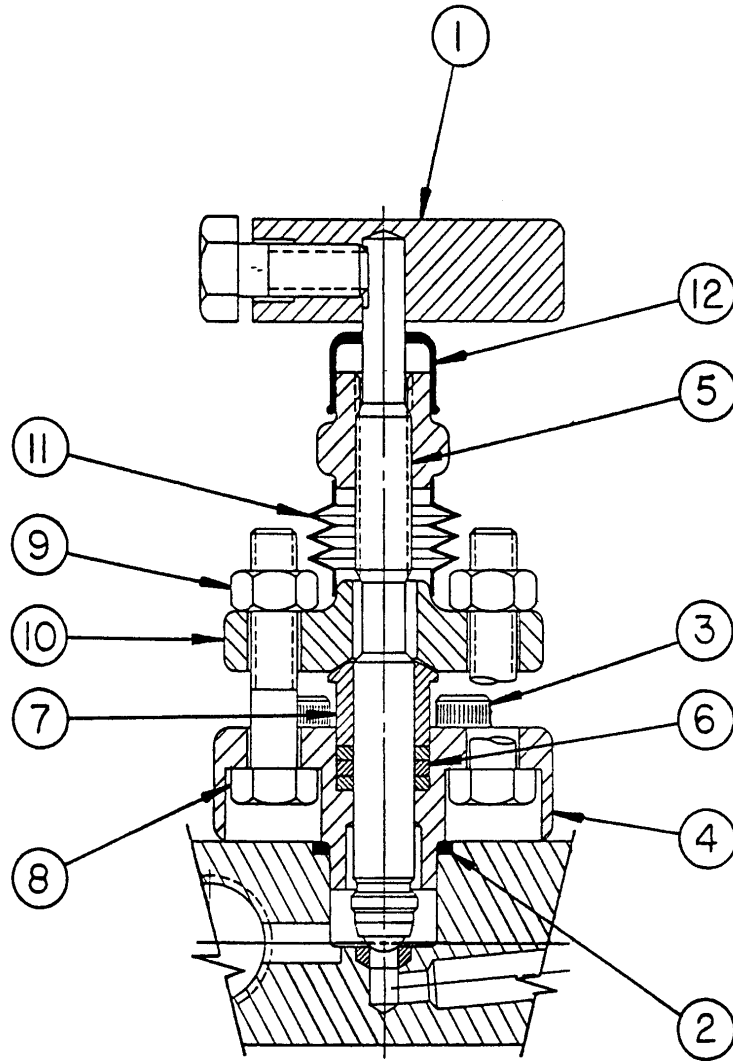

FIGURE 1