

ANDERSON, GREENWOOD & CO.

DWN	M. MOYERS	10-15-82	INSTALLATION, OPERATION AND MAINTENANCE		
CHK	(PC) D. BOYETT	11-12-82	INSTRUCTIONS FOR POWER INSTRUMENTATION		
ENGR	J. SPAHR	11-16-82	PBT HAND VALVES AND MANIFOLDS		
PROD	M. LEMBURG	11-12-82	SIZE	REPORT NUMBER	REV
QA	J. BACA	5-07-84	A	05.9040.095	H
APPR			PAGE 1 OF 15		

REVISIONS		
REV.	DESCRIPTION	APPROVALS/DATE
H	ECR #93-257-29	S.WILLIS 9-16-93 R.VIRGIL 10-05-93 J.CONLEY 10-05-93 J.SPAHR 10-05-93

1.0 INTRODUCTION

Anderson, Greenwood & Co. power industry hand valves and manifolds are metal seated valves designed for high temperature service. The seats are globe type with a stainless steel ball in line contact with the orifice. The valves are furnished with Grafoil packing and are available with a variety of end connections. AGCO power instrumentation valves are designed, manufactured and tested to comply with ASTM material codes and the ANSI B31.1 Power Piping Code. For maximum pressure/temperature ratings, see the applicable valve submittal drawing.

2.0 INSTALLATION

- 2.1 Check hand valve body for flow arrow for proper flow orientation. If no flow arrow is stamped on the valve body, flow may be in either direction.
- 2.2 Check manifold nameplate, if so equipped, for schematic of valve arrangement and note which ports are for process connections and instrument connections.
- 2.3 For all field welds of pipe or tube to valves, it is recommended that the valve seat be in the partially open position during welding.
- 2.4 Immediately prior to valve installation, check the piping to which the valve or manifold is to be connected for cleanliness and freedom from foreign materials.

2.5 THREADED VALVE INSTALLATION

Threaded pipe joints depend on a good intimate fit between the male and female pipe threads, therefore the use of a thread sealant is recommended and the pipe fitting connections must be made up tight.

2.6 WELD JOINT VALVE INSTALLATION

Welded joints, properly made, provide a structural and metallurgical continuity between the pipe and the valve body. All welding should be in accordance with any Code or jurisdictional regulations applicable to the piping system construction and with complete and approved welding procedures.

Heat input should be kept to a minimum by controlling the amperage and voltage to the lowest practical levels. A minimum travel speed of three (3) I.P.M. should be maintained and the interpass temperature should not exceed 200° F. The process employed should be GTAW with argon gas and a maximum diameter weld rod of 1/8".

2.7 TUBE FITTING VALVE INSTALLATION

AGCO Tube fittings come in the valve completely assembled and ready for immediate use. Only three steps are required for valve installation.

2.7.1 Insert the tubing through the compression nut and ferrule, and into the fitting port, making sure the tubing rests firmly against the shoulder in the port. Tighten the compression nut finger tight.

2.7.2 Scribe an alignment mark on the valve body and the compression nut.

2.7.3 With a wrench, tighten the compression nut one full turn until the alignment marks are again aligned. Tighten the compression nut an additional 1/4 turn. Installation is now complete.

2.8 PANEL MOUNTING VIA THE BONNET

The following procedure must be followed for panel mounting AGCO hand valves and manifolds via the bonnet. See Figure 5 for part reference.

2.8.1 Turn the bonnet handle to the full open position.

2.8.2 Loosen the handle bolt and remove the handle.

2.8.3 Loosen the jam nut on the bushing that is against the bonnet, then remove the bushing/jam nut assembly.

2.8.4 Unscrew the panel nut that is against the bonnet lock device. Do not remove the bonnet lock device.

2.8.5 Insert the valve bonnet into the panel hole and attach with panel nut. Make sure the bonnet lock device is properly positioned over the lock pin in the valve body before tightening. Tighten down the panel nut on top of the panel to 10-15 ft-lb of torque.

2.8.6 Thread the bushing/jam nut assembly over the stem and onto the bonnet. Hand tighten the bushing against the packing.

2.8.7 Fit the handle over the stem and tighten the handle bolt to the flatted part of the stem to 10-12 ft-lb of torque.

2.8.8 Tighten the bushing with a wrench till a resistance is felt while turning the bonnet handle. Tighten the jam nut firmly to the bonnet. The packing may need to be readjusted if leakage occurs when the system is repressurized.

3.0 OPERATION

Hand valves and manifolds which have been reasonably matched to a typical valve service application and properly installed in its piping system can expect to have a long service life with a minimum of attention. However, these valves have moving and wearing parts and depend on long term preservation of highly finished surfaces on these parts for satisfactory valve performance.

- 3.1 The use of a "cheater" to operate the valve handle is not necessary and not recommended. This practice can cause valve damage.
- 3.2 All hand valves and manifolds have rising stems with right hand thread. Rotate the handle counter-clockwise to open and clockwise to close. In the closed position, the valve should be seated at 4-5 ft-lb of torque.
- 3.3 Bonnets with rising stems are provided with a backseat. Backseats in rising stem bonnets should be considered basically as stops to prevent overtravel when opening valves. It is recommended not to leave the upper stem in the backseated position. Note MSS SP-92, "MSS Valve User Guide", paragraph 4.3 .

3.4 OPERATION OF 2 VALVE MANIFOLDS

The schematic for two valve manifolds is shown in Figure 1. These valves are designed for use on static pressure transmitters, switches or gages.

- 3.4.1 In normal operation of the system the block valve between the process and instrument ports will be open and the calibration valve will be closed.
- 3.4.2 To check zero, close the block valve to isolate the instrument from the system. Open the calibration valve to bleed the instrument pressure to atmospheric pressure. When fully vented, the instrument should show zero output. A threaded outlet is provided for field spot-check or reset of the instrument.

3.5 OPERATION OF 3 VALVE MANIFOLDS

The schematic for three valve manifolds is shown in Figure 2. The manifolds are designed for use with differential pressure transmitters or other flow metering instruments. Two valves on the sides of the body are block valves for shutting off their high and low side connections to the d/p transmitter when the instrument is to be adjusted or removed from service. The third valve in the center of the body is an equalizing valve for equalizing pressure on the two sides of the instrument while checking zero.

- 3.5.1 In normal operation of the system the two block valves will be open and the equalizer valve will be closed.

3.5.2 To check zero, close the block valve to the low pressure side (downstream side) of the instrument and open the center valve to equalize the pressure on both sides of the instrument.

3.5.3 To return to service, close the equalizer valve and open the block valve to the low pressure side of the instrument.

3.6 OPERATION OF 5 VALVE MANIFOLDS

The schematic for five valve manifolds is shown in Figure 3. These manifolds are designed for use with various types of transmitters for measuring differential pressure. The five valve manifold is similar to the three valve manifold in that it has two line block valves and an equalizer valve. The other two valves are isolation valves for the calibration and test ports which are integral with the manifold.

3.6.1 In normal operation of the system, the two block valves will be open with the equalizer and two test valves closed.

3.6.2 To readjust the instrument to zero, close the block valve to the low pressure (downstream) side of the instrument and open the center valve to equalize pressure on both sides of the instrument.

3.6.3 To perform a span calibration check on the instrument, both line block valves are closed. Open the equalizer valve and crack the downstream test valve to release pressure. After the pressure is released, close the equalizer valve. Install calibration input signal tubing to the upstream test port and open the corresponding test valve. The instrument may now be checked for calibration.

3.6.4 To return the instrument to service, close both test valves. Open the upstream line block valve and the downstream block valve.

3.7 OPERATION OF 7 VALVE MANIFOLDS

The schematic for seven valve manifolds is shown in Figure 4. The seven valve manifold is similar the five valve manifold but two valves are added to facilitate line drainage or blowdown.

3.7.1 See steps 3.6.1 through 3.6.3 for normal, zeroing and testing instructions.

3.7.2 For drainage or blowdown, close the two block (inlet) valves, test port valves and equalizer valve. Open both drain valves.

3.7.3 To return the instrument to service, close both drain valves, and open the upstream line block valve and then the downstream block valve.

4.0 HAND VALVE AND MANIFOLD MAINTENANCE

The important performance parameters are pressure boundary integrity, actuating force required, and internal leak tightness. Maintenance should logically address the importance of preserving the performance parameters.

Valves which remain in one position for long periods of time may be subject to some degree of inoperativeness as a result of loss of effective lubricant in the threads, aging of the packing surface, corrosion of moving parts or accumulation of harmful solids. In some applications it may be desirable to schedule periodic partial or full cycle exercising of these valves.

- 4.1 Stem seal leakage usually results from packing wear and can usually be corrected by tightening the packing bushing. Over tightening can cause high stem friction, accelerated wear and shortened packing life.
- 4.2 If packing replacement is needed, the following steps should be followed after the valve has been isolated from the line pressure and pressure bled off. Refer to Figure 6 for parts identification.
 - 4.2.1 Open the bonnet by turning the handle till the stem backseats.
 - 4.2.2 If the bonnet was supplied with a bonnet lock, loosen the panel nut on top of the bonnet lock and thread it up the bonnet as far as it will go. Lift the bonnet lock, exposing the bonnet hex.
 - 4.2.3 If the bonnet was not supplied with a bonnet lock, remove the spring pin in the body with a pair of pliers.
 - 4.2.4 Loosen the bonnet from the valve body.
 - 4.2.5 Loosen the handle bolt and remove the handle.
 - 4.2.6 Loosen the jam nut on the bushing against the bonnet. Remove the bushing, stem, follower, then the two end rings and three packing rings. Replace the stem through the bonnet.
 - 4.2.7 Lightly coat the new packing with packing lubricant. Insert into the packing cavity one new end ring, three rings of new packing, and then a second new end ring. Insert follower over second end ring.
 - 4.2.8 Thread the bushing onto the stem and into the bonnet. Tighten the bushing to 10-15 ft-lb of torque. Tighten the jam nut firmly against the bonnet.
 - 4.2.9 Install and tighten the handle to the upper stem to 10-12 ft-lb of torque.
 - 4.2.10 Lightly coat the bottom threads of the bonnet with lubricant. If using a bonnet lock, place the lock, slotted end down, up onto the bonnet. Screw the bonnet back into the seat cavity by hand.
 - 4.2.11 Torque the bonnet to 35-40 ft-lb of torque.

- 4.2.12 Once the system is pressurized, further tightening of the bonnet to body joint and packing bushing may be required to stop leakage. Tighten these in 5 ft-lb increments until the leakage has stopped.
- 4.2.13 If using a bonnet lock, lower the lock over the lock pin. Tighten panel nut over bonnet lock to 10-15 ft-lb of torque.
- 4.2.14 If not using a bonnet lock, install a spring pin in the pin hole which is best centered with respect to the bonnet hex.
- 4.3 If it should become necessary to replace an entire bonnet assembly, the following steps must be followed after the valve has been isolated from the line pressure and pressure bled off. Refer to Figure 6 for parts identification.
 - 4.3.1 Open the bonnet by turning the handle till the stem backseats.
 - 4.3.2 If the bonnet was supplied with a bonnet lock, loosen the panel nut on top of the bonnet lock and thread it up the bonnet as far as it will go. Lift the bonnet lock, exposing the bonnet hex.
 - 4.3.3 If the bonnet was not supplied with a bonnet lock, remove the spring pin in the body with a pair of pliers.
 - 4.3.4 Loosen the bonnet from the valve body.
 - 4.3.5 Lightly coat the bottom threads of a new bonnet with lubricant. If using a bonnet lock, place the lock, slotted end down, up onto the new bonnet. Screw the new bonnet back into the seat cavity by hand.
 - 4.3.6 Torque the new bonnet to 35-40 ft-lb of torque.
 - 4.3.7 Once the system is pressurized, further tightening of the bonnet to body joint and packing bushing may be required to stop leakage. Tighten these in 5 ft-lb increments until the leakage has stopped.
 - 4.3.8 If using a bonnet lock, lower the lock over the lock pin. Tighten panel nut over bonnet lock to 10-15 ft-lb of torque.
 - 4.3.9 If not using a bonnet lock, install a spring pin in the pin hole which is best centered with respect to the bonnet hex.

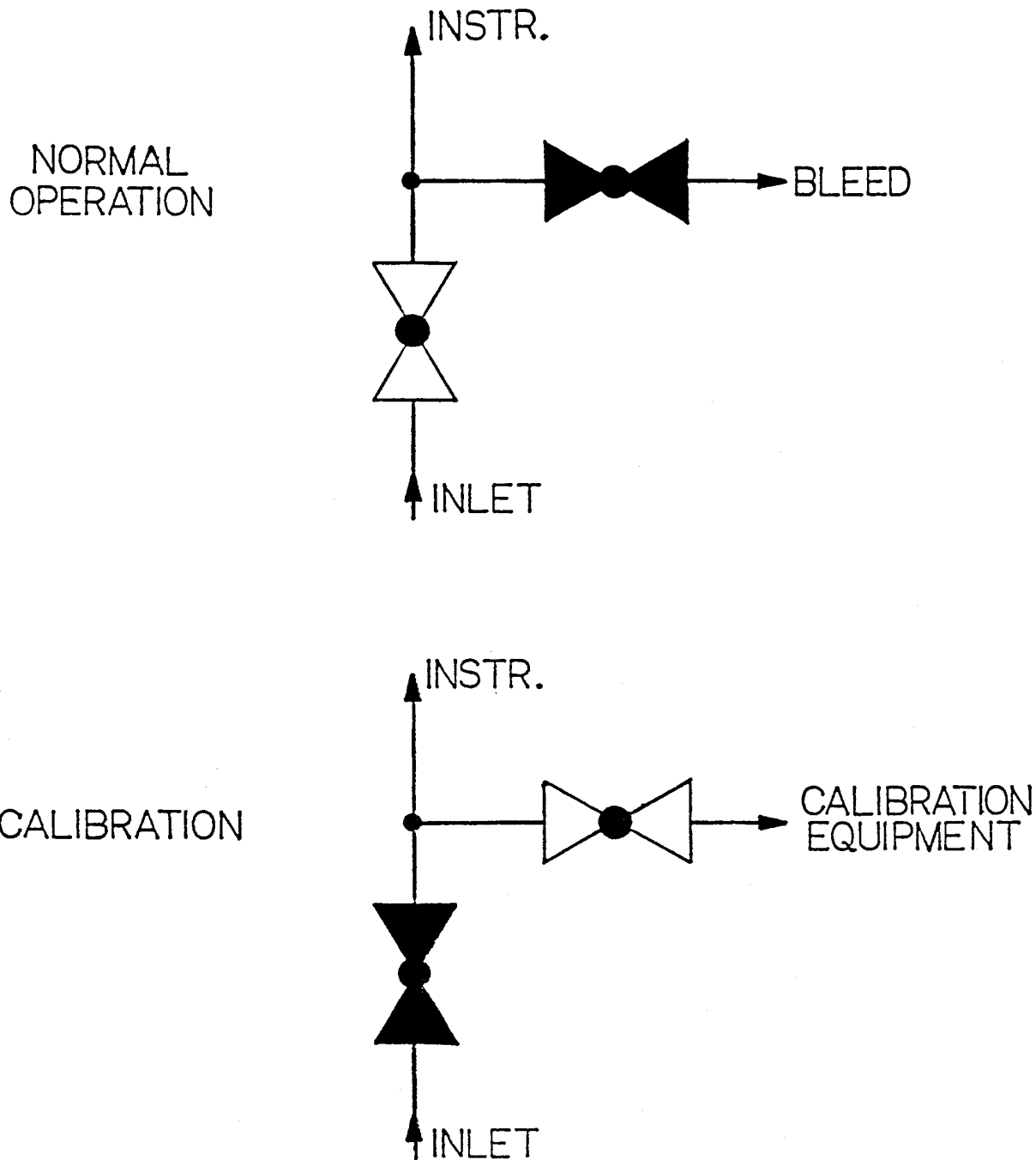
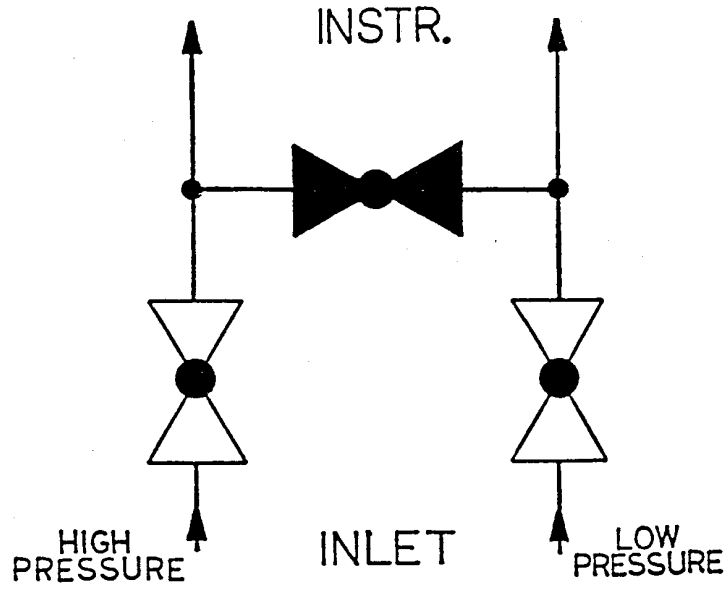

FIGURE 1

NORMAL
OPERATION



ZEROING

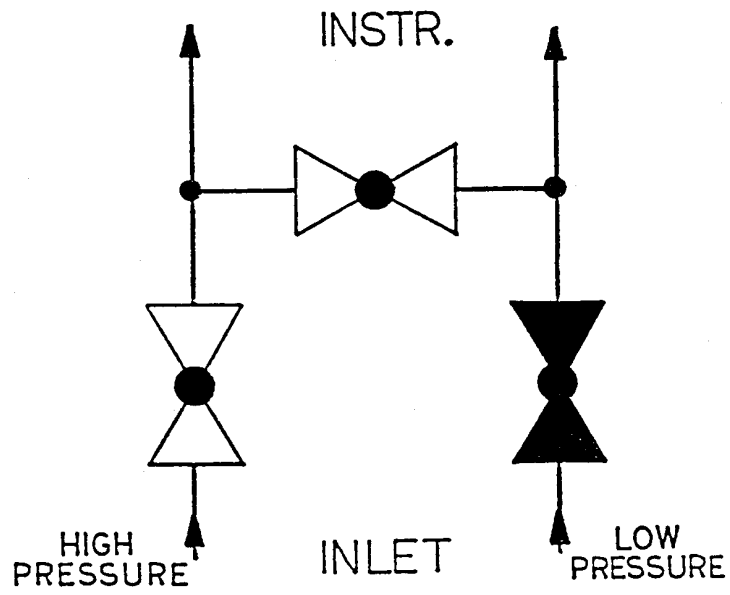

FIGURE 2

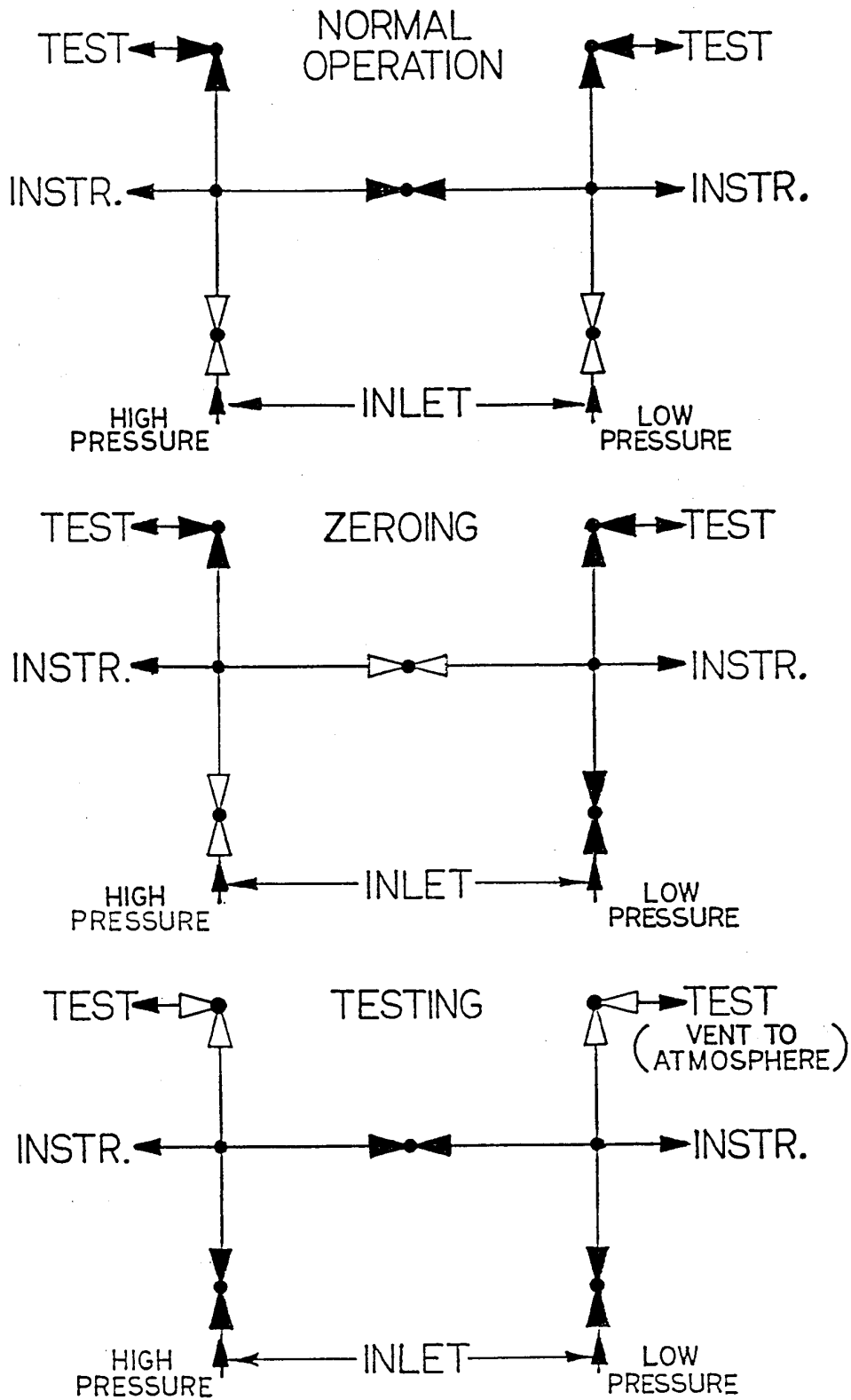

FIGURE 3

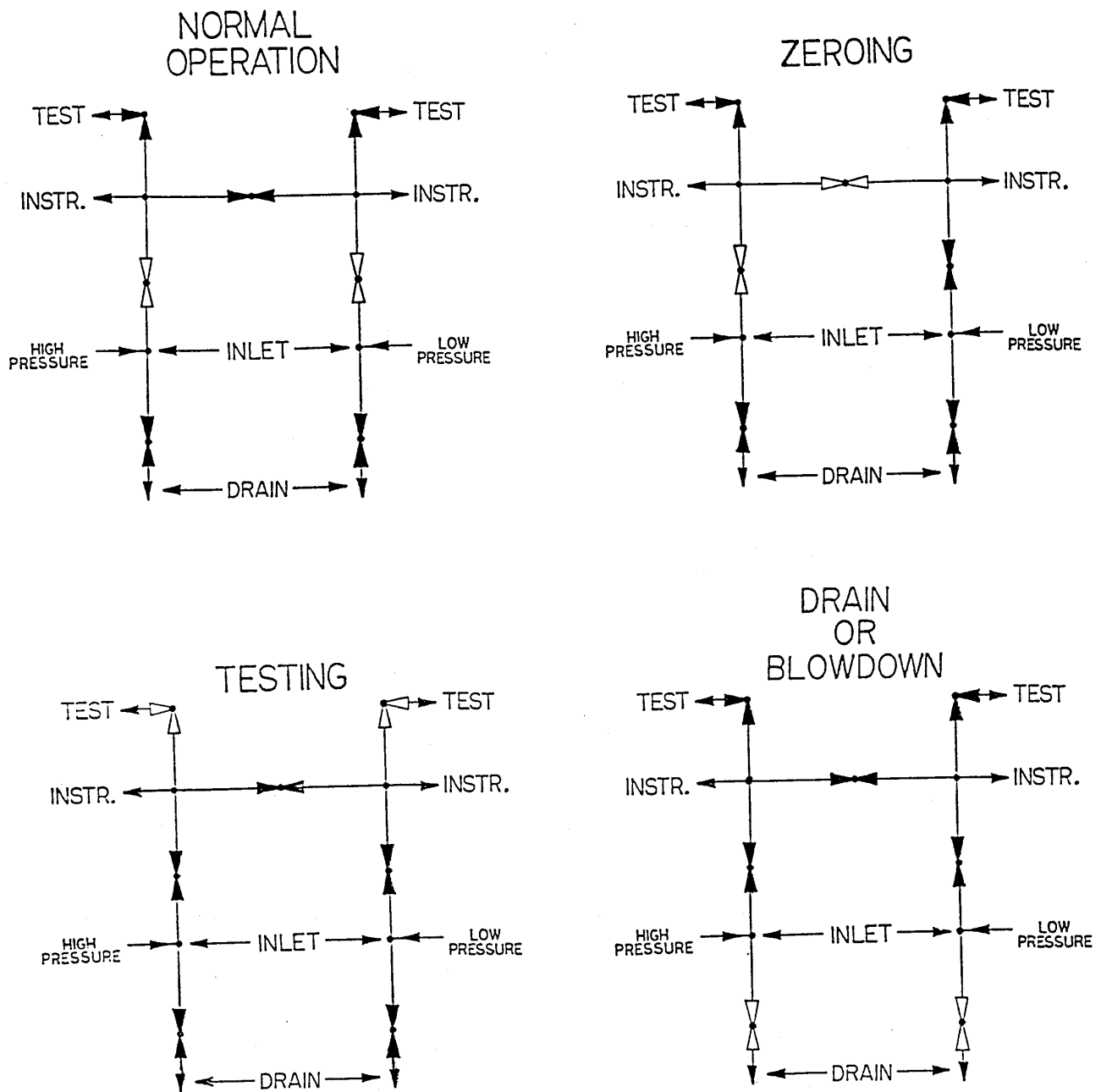

FIGURE 4

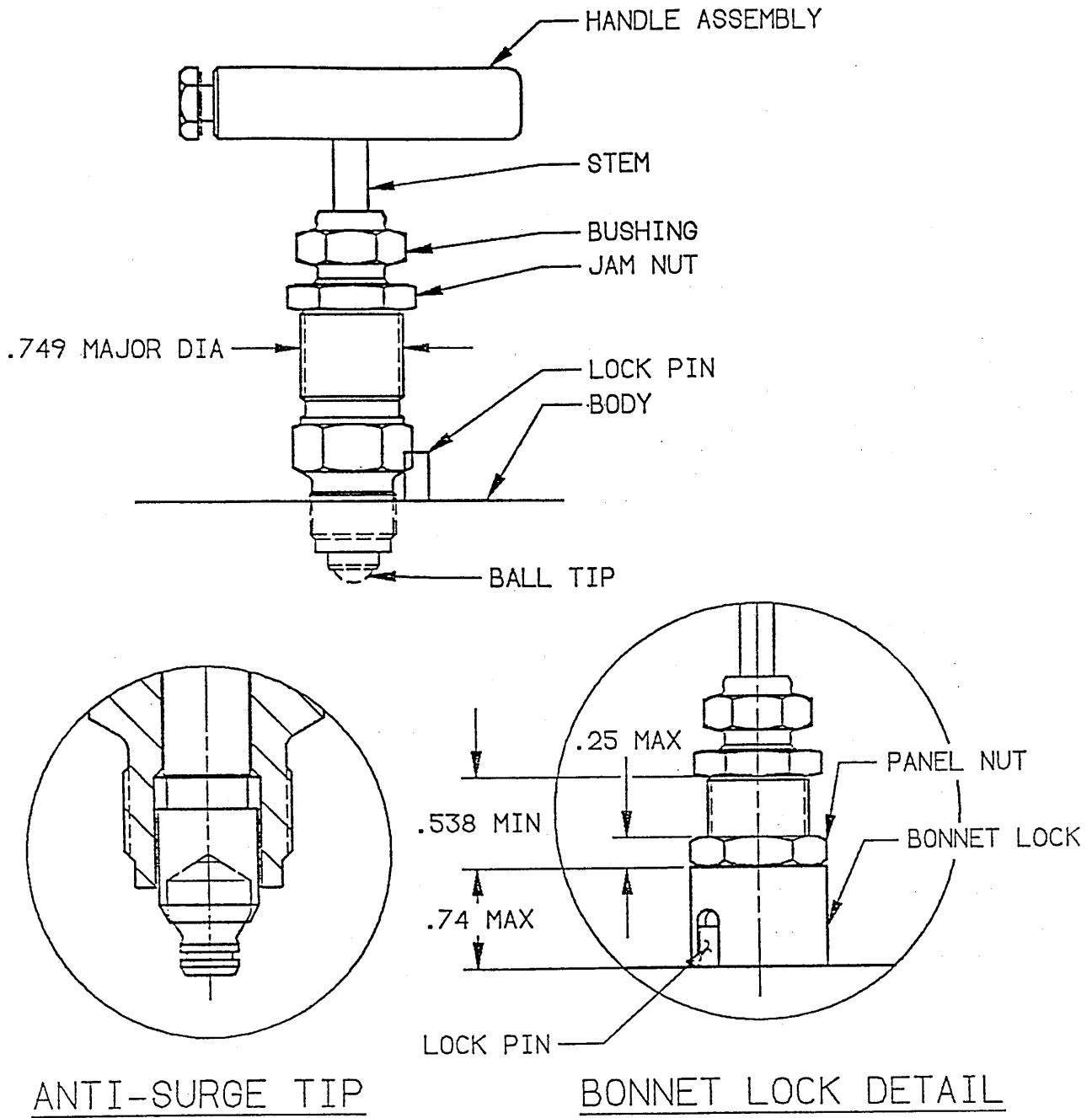

FIGURE 5

HIGH TEMPERATURE "PBT" BONNET ASSEMBLY

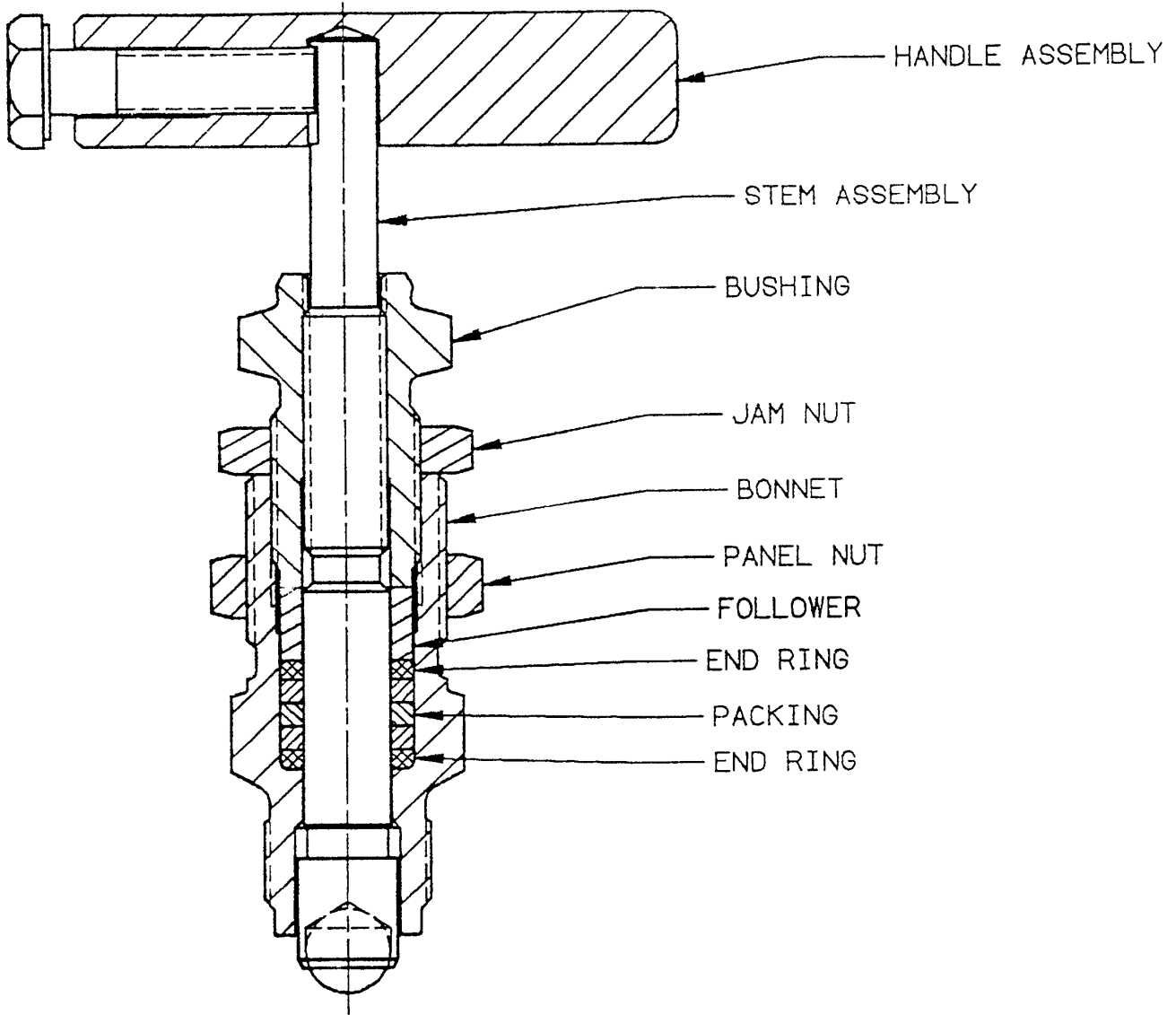
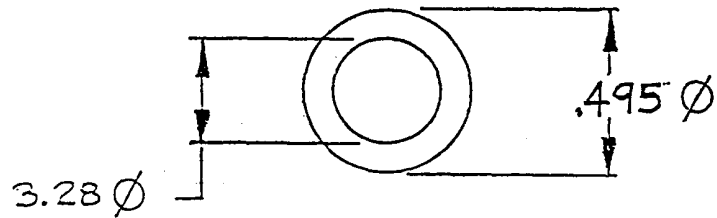
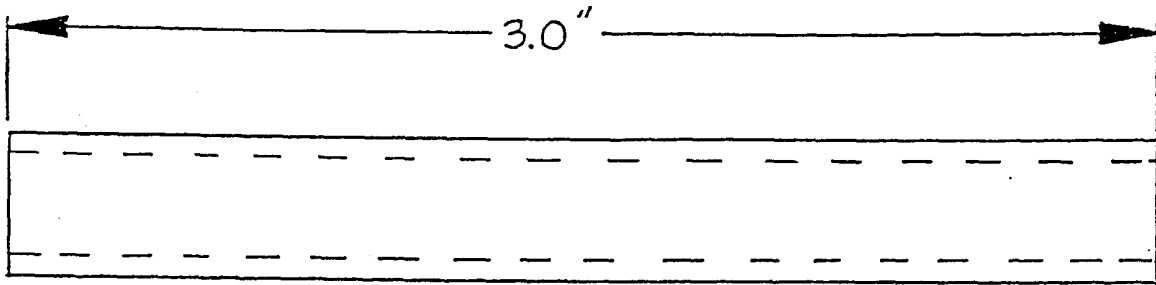

FIGURE 6
PBT BONNET ASSEMBLY



SUGGESTED CONFIGURATION OF
STEM PACKING TAMPING TOOL

FIGURE 7