

# ANDERSON GREENWOOD

**Before installation these instructions must be fully read and understood.**

Instructions - Maintenance for Series 9290 POSRV (Pilot Operated Safety Relief Valve) with Flowing Modulating or Snap Action Pilot. The intent of these instructions is to acquaint the user with the storage, installation and operation of this product. **Please read these instructions carefully before installation.**

## Safety Precautions

When the pressure/vacuum relief valve is under pressure never place any part of your body near the pilot exhaust nor the outlet of the main valve.

The main valve outlet should be piped or vented to a safe location.

Always wear proper safety gear to protect head, eyes, ears, etc. anytime you are near pressurized valves.

Never attempt to remove the pressure/vacuum relief valve from a system that is pressurized.

Never make adjustments to or perform maintenance on the pressure/vacuum relief valve while in service unless the valve is isolated from the system pressure. If not properly isolated from the system pressure, the pressure/vacuum relief valve may inadvertently open resulting in serious injury.

Remove the pressure/vacuum relief valve prior to performing any pressure testing of the system.

The safety of lives and property often depends on the proper operation of the pressure/vacuum relief valve. The valve must be maintained according to appropriate instructions and must be periodically tested and reconditioned to ensure correct function.

## Warning

Removal of the seal wires in an attempt to adjust and/or repair this product by unauthorized or unqualified persons voids the product warranty and may cause damage to equipment and serious injury or death to persons.

The product is a safety related component intended for use in critical applications. The improper application, installation or maintenance of the product or the use of parts or components not manufactured by Anderson Greenwood may result in a failure of the product.

Any installation, maintenance, adjustment, test, etc. performed on the product must be done in accordance with the requirements of all applicable Anderson Greenwood procedures and instructions as well as applicable National and International Codes and Standards.

## Storage and Handling

Pressure/vacuum relief valve performance may be adversely affected if the valve is stored for an extended period without proper protection. Rough handling and dirt may damage, deform, or cause misalignment of valve parts and may alter the pressure setting and adversely affect valve performance and seat tightness. It is recommended that the valve be stored in the original shipping container in a warehouse or as a minimum on a dry surface with a protective covering until installation. Inlet and outlet protectors should remain in place until the valve is ready to be installed in the system.

## Table of Contents

1.0	General Valve Description and Instructions .....	2
2.0	Main Valve Maintenance .....	3
3.0	Pilot Maintenance .....	14
4.0	Pilot Adjustment.....	21
5.0	Leak Testing the Assembly .....	23
6.0	Field Test Instructions-Positive Pressure Pilot .....	23
7.0	Repair Kits .....	25
8.0	Accessory Repair .....	26



Total Flow Control Solutions™

## 1.0 General Valve Description (Refer to Figure 1)

### 1.1 Operation

The 9290 Pilot Operated Safety Relief Valve uses the principle of pressurizing a large diaphragm area, referred to as dome, with tank pressure to hold the main valve seat closed up to set pressure. At set pressure the pilot actuates to partially reduce the pressure in the dome, and the downward force acting on the main seat. The seat then lifts to relieve tank pressure. When the tank pressure is reduced, the pilot actuates to repressure the dome with tank pressure to close the main valve.

### 1.2 Installation

Inlet flanges are designed for use with 150 class ANSI flanges. Installation of studs is required in the base of the vent. Remote pressure pickup is mandatory on all pressure/vacuum or vacuum only units. Internal sense is standard on pressure only units.

### 1.3 Start-Up

There must be pressure at the vent inlet to establish a closing force across the main vent element. Pressure must pass through the pilot supply tube and pilot and exert force on the main diaphragm. On normal plant start-up the vent loads itself without incident as tank pressure increases. It is not uncommon that slight leakage past the seat occurs until system pressure reaches the dome chamber.

If block valves are used under the safety vent, be sure all block valves are open. If block valves are opened after system start-up the safety vents briefly vent to the atmosphere past the main seat before the dome gets pressurized. It will close off positively once dome pressure has been established. Open the block valve slowly to minimize venting.

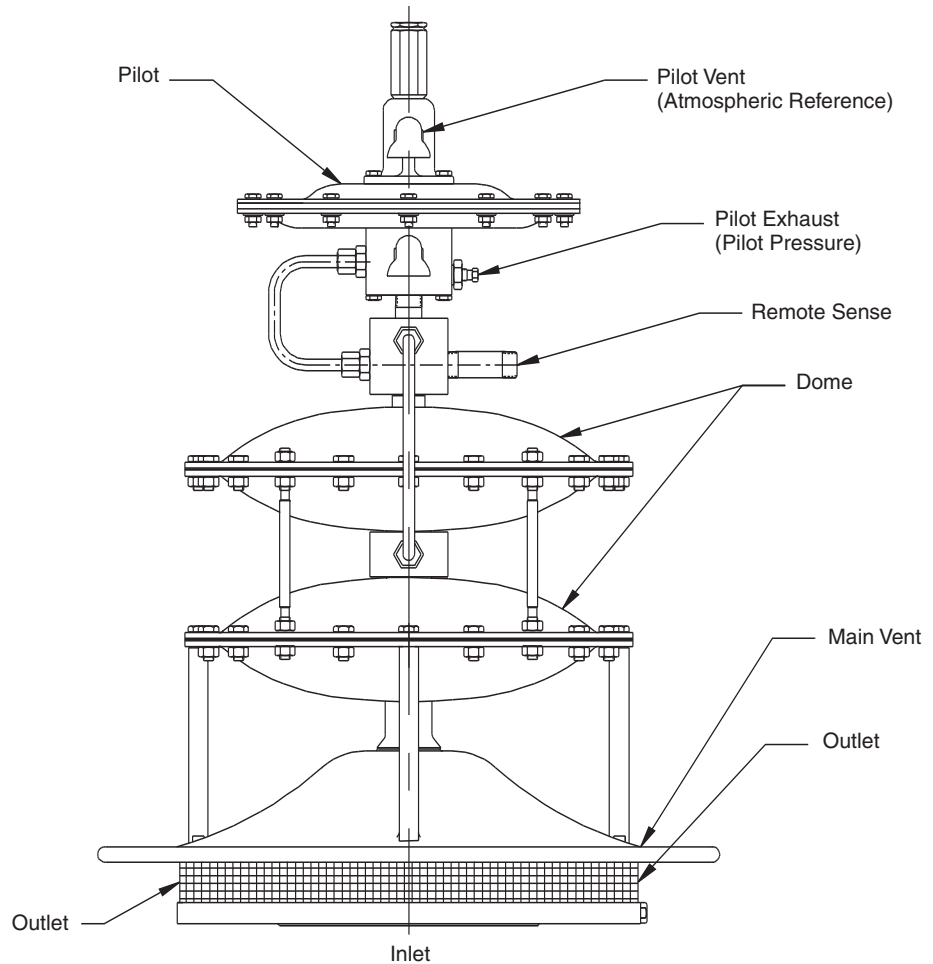

Figure 1

## 2.0 Main Valve Maintenance (Refer to Figure 2)

### 2.1 General

Since the Series 9290 vent can be either a pressure only, a vacuum only, or a pressure/vacuum relieving device, it is built in a modular fashion. The standard single diaphragm unit will function on pressure and vacuum, however opening under very low vacuum requires use of the auxiliary diaphragm chamber. The vent can also be repaired in a modular fashion. The seat can be replaced without complete disassembly of the diaphragm cases. Selective repair can be performed as required.

### 2.2 Main Seat Replacement

- Remove bolts (700) that connect the main diaphragm case to the vertical column supports (830).
- Remove the operational assembly including diaphragm cases (210, 280), shield (860), and seat plate assembly (Details “D” and “E”) as a single unit.  
**NOTE: Use a hoist on large sizes.**
- While holding the shield (860) up, unscrew the seat plate assembly from the shaft (320). This is normally a hand operation, however a  $\frac{9}{16}$ ” [14.3 mm] wrenching flat is provided on the seat hub (420) if required. The connecting thread will run free then tighten and run free again as it disengages from a locking helicoil (330) in the vertical shaft (320).
- Refer to Figures 4, 5 and 6, (Details “D” and “E”) for the appropriate valve seat plate size, material and pressure range. Remove the seat jam nut (450) and screws (120) and nuts (130) or seat band clamp (125). Remove the seat retainer (140). Remove seat film (610).
- Install new seat film (610) and reassemble hub (420) in accordance with Detail “D”.  
**NOTE: On reassembly pay special attention to the stack-up sequence to make sure the parts are assembled properly.**
- Install seat retainer (140) over new film per Detail “E” and cross tighten seat screws (120) and nuts (130) until secure.
- On the stainless steel seat plate with band clamp (125), tighten clamp before tightening seat jam nut (450).
- Reinstall seat plate assembly to main shaft (320). **NOTE: Shield (860), tube (760), and seal (650) must be in place before installation of seat assembly.**
- The thread on the seat plate assembly will at first run free then tighten then run free again. The seat plate assembly is then in place and will swivel to assure good seat contact on the nozzle (460). **NOTE: Seat hub (420) must not be tightened to shoulder tightly on the shaft (320).**

## 2.3 Diaphragm Replacement

### 2.3.1 All Dual Chamber Diaphragm 9290C Models (Refer to Figure 3)

- Remove the pilot and tubing from the auxiliary diaphragm case.
- Remove the upper auxiliary diaphragm case (210).
- Install a small retaining wire in the lift rod (250) as shown in Figure 6, Detail "C" to retain the lift rod.
- Lift the auxiliary and main diaphragm assemblies to the full open position using the auxiliary vacuum plate (160B). The open dome port can be temporarily capped to hold the main diaphragm assembly up.
- Remove nuts (530 and 520B) and O-ring (670), Figure 6, Detail A.
- The lift rod (250) is attached to the auxiliary plate bushing (240) with threads. See Figure 6, Detail "A". Unscrew the lift rod (250) from the plate bushing (260) by rotating the rod. The rod will unscrew from the bottom of the assembly. An extension on the upper end of the rod has been provided if wrenching is required. The Auxiliary diaphragm assembly can now be removed to replace the auxiliary diaphragm (170B).  
**NOTE: On 2" and 3" valves with aluminum internals or low pressure stainless steel internals, a diaphragm reinforcement (175B) is used under the auxiliary diaphragm and should also be replaced.**
- Remove the jam nut (520B) on the auxiliary diaphragm assembly and replace diaphragm (170B) and diaphragm reinforcement (175B), where used.  
**NOTE: See Figure 6, Detail "A" and pay special attention to the stack-up sequence on reassembly.**
- Remove the main diaphragm case bolts (700/710). Remove the studs (840) from the column supports (830). Remove the lower auxiliary diaphragm case (280B) and the upper main diaphragm case (220) as a unit, assembled to the diaphragm case adapter (230). Allow the lift rod (250) to slip from the center hole and lift items (280B), (220) and (230) upwards as one unit.
- Remove the main diaphragm assembly, lower main diaphragm case (280A) and seat plate assembly from the base. **NOTE: On the 2" and 3" valves a reinforcement diaphragm (175A) is used between the main diaphragm (170A) and the lower main diaphragm case (280A). It should be replaced also.**
- See Figure 6, Detail C. Remove jam nut (520A) and disassemble. Replace main diaphragm (170A) and diaphragm reinforcement (175A), where used.  
**NOTE: Pay special attention to stack sequence shown.**
- Remove the O-ring (690) from the upper end of the adapter bore (230). Lubricate O-ring with Dow Corning FS3451 or equivalent when the new one is installed.  
**NOTE: For oxygen service valves, use only lubricants suitable for this service, such as Krytox 240AC.**
- If cap gaskets (620A) are to be replaced, apply Teflon® gasketing to upper diaphragm cases (210, 220) only as shown in Figure 7.
- Reassemble in reverse order. Apply a light film of Dow Corning No. 33 silicone grease or equivalent to all threaded parts. **NOTE: For oxygen service valves, use only lubricants suitable for this service, such as Fluorolube LG-160.**

Teflon® is a registered trademark of E.I. du Pont de Nemours Company.

### 2.3.2 All Single Chamber Diaphragm 9290P Series (Refer to Figure 2)

- Remove pilot and tubing from the diaphragm case.
- Remove the upper main diaphragm case (220).
- Remove the main diaphragm assembly, lower main diaphragm case (280) and seat plate assembly from the base (100). **NOTE: On the 2" and 3" valves, a reinforcement diaphragm (175) is used between the main diaphragm (170) and the lower main diaphragm case (280).**
- See Figure 6, Detail C. Remove jam nut (520A) and disassemble. Replace main diaphragm (170) and diaphragm reinforcement (175), where used. **NOTE: Pay special attention to stack sequence shown.**
- Remove remaining internal assembly as a unit including lower diaphragm case (280), and internal assembly.
- If cap gasket (620) is to be replaced, apply Teflon® gasketing to upper diaphragm case (210) as shown in Figure 7.
- Reassemble in reverse order. Apply a light film of Dow Corning No. 33 silicone grease or equivalent to all threaded parts. **NOTE: For oxygen service valves, use only lubricants suitable for this service, such as Fluorolube LG-160.**

### 2.4 Nozzle Replacement (Refer to Figure 2 or 3)

- Remove nozzle retaining screws (110) and gently tap nozzle (460) with soft face mallet. **NOTE: Inspect nozzle seating surface for nicks or scratches. If they cannot be removed with crocus cloth or fine sandpaper, the nozzle must be remachined.**
- Nozzle face can be remachined. Do not remove more than 0.060" [1.52 mm] of material.
- If nozzle gaskets (630) are to be replaced, install Teflon® gasketing as shown in Figure 7.
- Reinstall nozzle (460) and retaining screws (110).

**Main Vent Parts List (Single Chamber)**

<b>Item</b>	<b>Description</b>
100	Base Flange
110	Screw Nozzle Retainer
120	Screw - Seat
125	Clamp Band - Seat
130	Nut, Lock
140	Retainer - Seat
150	Plate - Main Pressure
160	Plate - Main Vacuum
170	Diaphragm - Main
175	Diaphragm Reinforcement (Used on 2" and 3" only)
210	Case, Upper Diaphragm
280	Case, Lower Diaphragm
300	Washers (Used on Aluminum Cases only)
320	Shaft - Assembly (Includes Item 330 As Part of Assy.)
330	Helicoil
340	Sleeve - Guide
360	Bushing - Split
420	Hub Seat
430	Spacer - Seat
440	Bushing - Seat
450	Nut Seat Jam
460	Nozzle (Assembly)
500	Bushing - Guide
520	Nut - Jam
530	Nut
580	Washer
590	Washer
600	Gasket Clamp Plate
610	Seat - Film
620	Gasket - Case
630	Nozzle Gasket
640	Spacer (O-ring/-018)
650	Weather - Seal
700	Cap Bolt - Hex
710	Cap Bolt - Eye (Not Shown Used on 4" and above)
730	Nuts (Used on Dual Chamber Diaphragm only)
760	Tube Thrust (Not Used on 2" or 3")
830	Column Support
850	Nuts
860	Shield - Deflector
870	Screen Seat
880	Bushing - Support
890	Screen - Lower Case
910	Plate - Seat
920	Plate - Seat Protector
970	Washer Seat (Used Prior to 1990)

NOTE: Refer to Figures 2, 4, 5

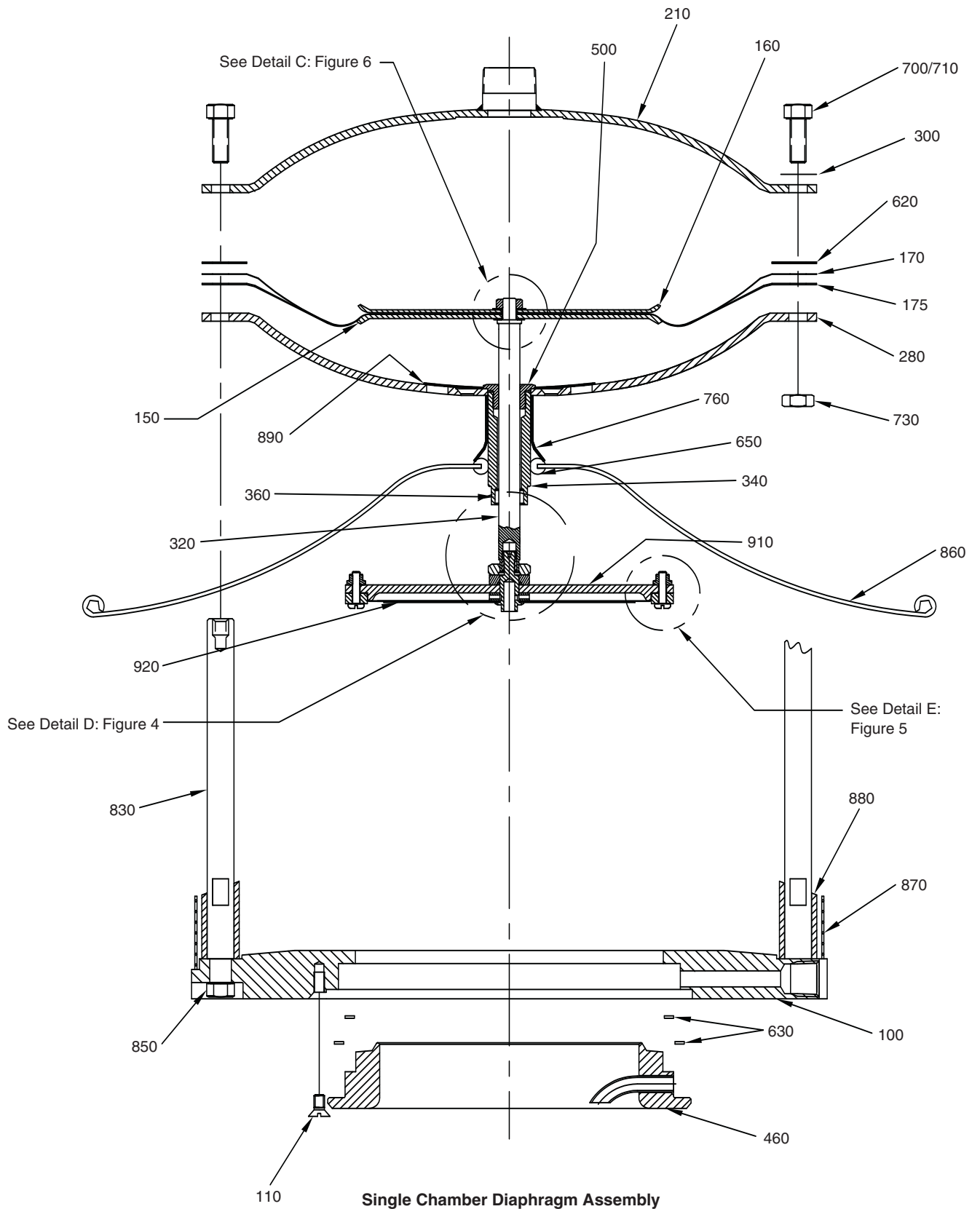
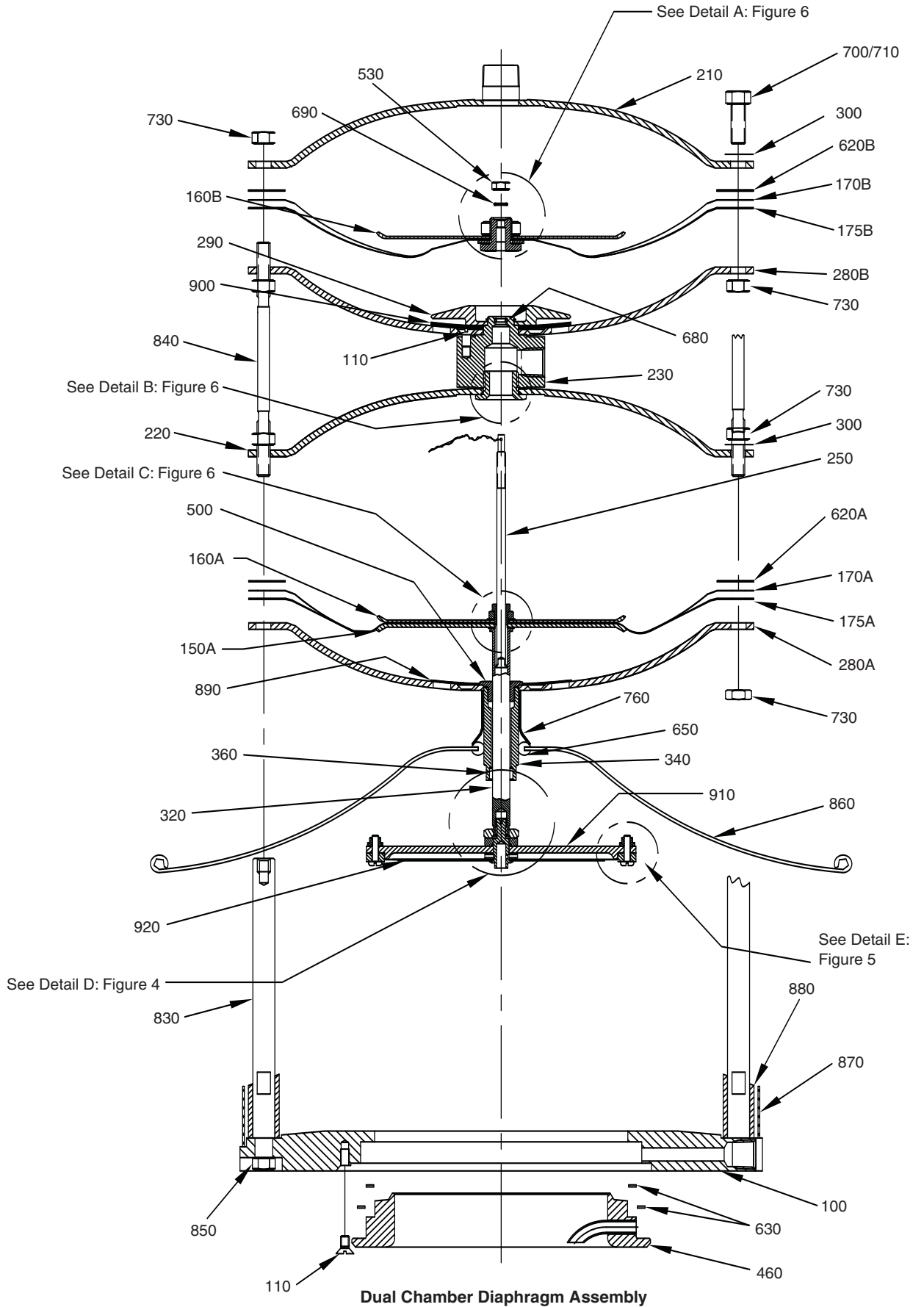

Figure 2

## Main Vent Parts List (Dual Chamber)

Item	Description
100	Base - Flange
110	Screw
150A	Plate - Diaphragm Bottom
160A	Plate - Diaphragm Top
160B	Plate - Auxiliary Vacuum
170A	Diaphragm - Main
170B	Diaphragm - Auxiliary
175A	Diaphragm Reinforcement, Main (Used on 2" and 3" only)
210	Case, Upper Auxiliary Diaphragm
220	Case, Upper Main
230	Adapter
240	Bushing
250	Rod
260	Bushing - Rod
270	Washer
280A	Case - Lower, Main (Not Used on 2" and 3")
280B	Case - Lower, Auxiliary
290	Plate - Auxiliary Pressure
320	Shaft - Assembly
340	Sleeve - Guide
360	Bushing Split (Not Used on 2" and 3")
460	Nozzle
500	Bushing - Guide
530	Nut
620A	Gasket - Diaphragm Case
650	Seal - Weather
660	Gasket - Adapter
670	Seal - Adapter
680	Ring - Retainer
690	Seal - Rod (Teflon® O-ring)
700	Bolt - Case
710	Eye Bolt (Used on 4" and above)
730	Nut
760	Tube Thrust (Not Used on 2" or 3")
830	Column Support
840	Stud
850	Nut - Column Retaining
860	Shield
870	Screen - Seat
880	Bushing Support
890	Screen - Lower Case
900	Screen - Upper Case
910	Plate - Seat
920	Protector - Plate

NOTE: Refer to Figures 3, 6



Dual Chamber Diaphragm Assembly

Figure 3

Engineering Doc. #05.9040.174 Rev. F

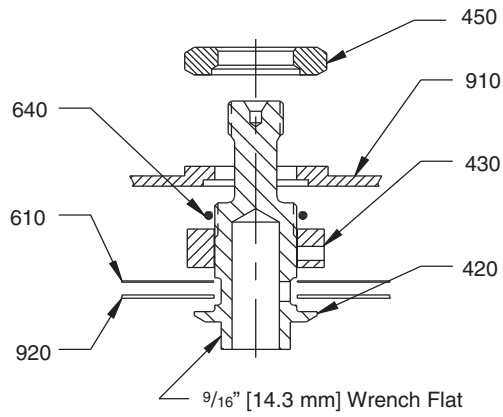

**2" thru 4" Valve Inlet Size, Aluminum**

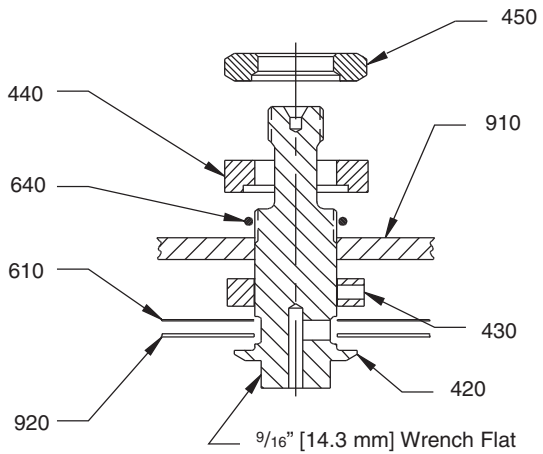

**6" Valve Inlet Size, Aluminum**

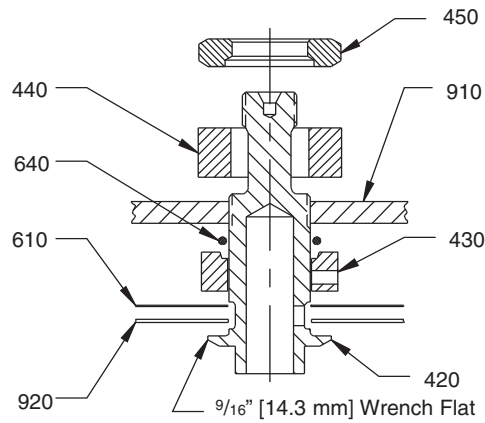

**8" thru 12" Valve Inlet Size, Aluminum**

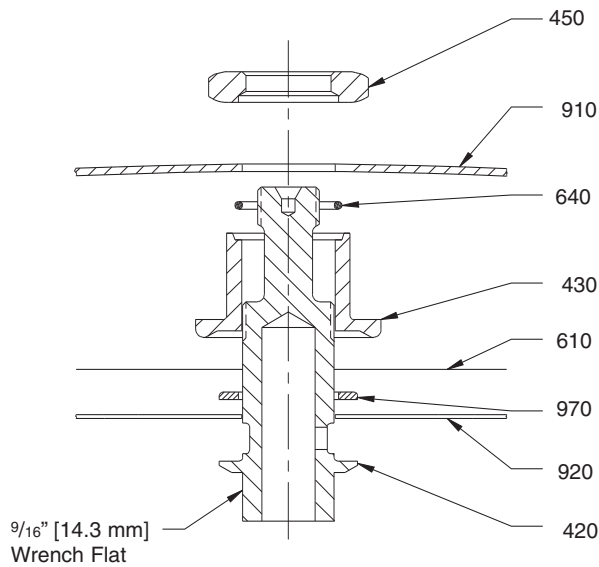

**Low Pressure Stainless Steel  
 2" thru 12" Valve Inlet Size**

**Main Valve Seat Plate Hub Assembly  
 Detail D, Figure 4**

**Low Pressure Aluminum  
 High Pressure Pressure Aluminum and Stainless Steel**

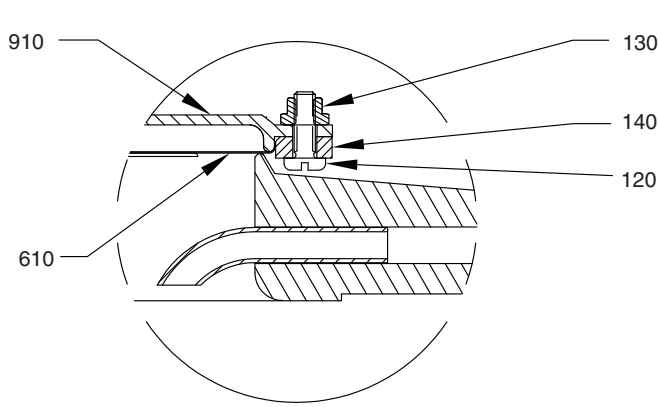

**2" Inlet Size**

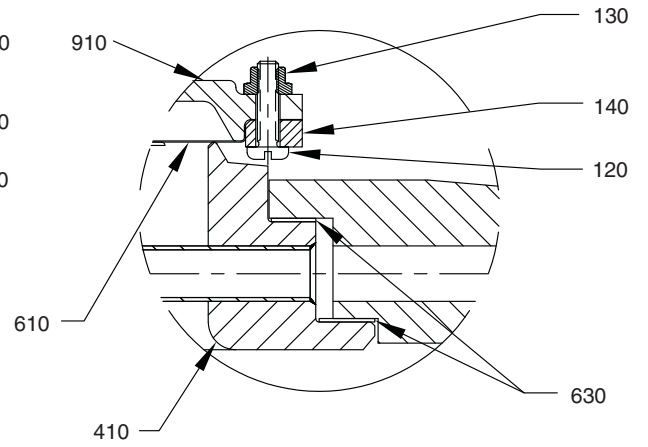

**3" thru 12" Inlet Size**

**Low Pressure Stainless Steel**

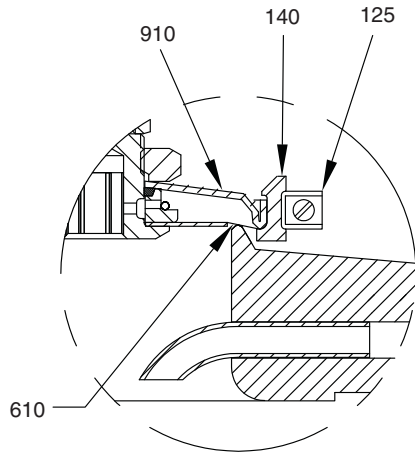

**2" Inlet Size**

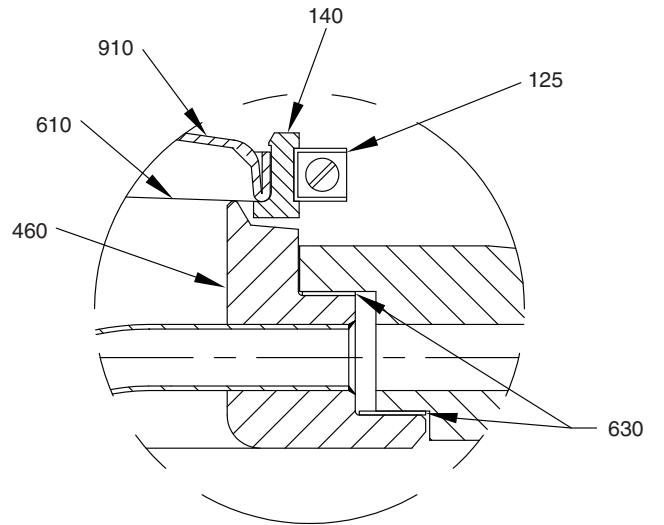

**3" thru 12" Inlet Size**

**Main Valve Seat Plate Assembly  
 Detail E, Figure 5**

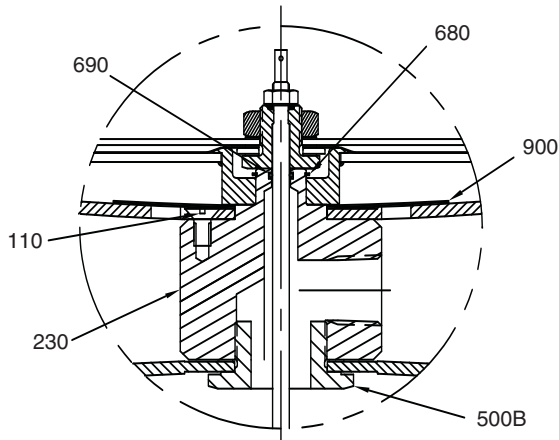

**Main and Auxiliary Chambers Assembled**

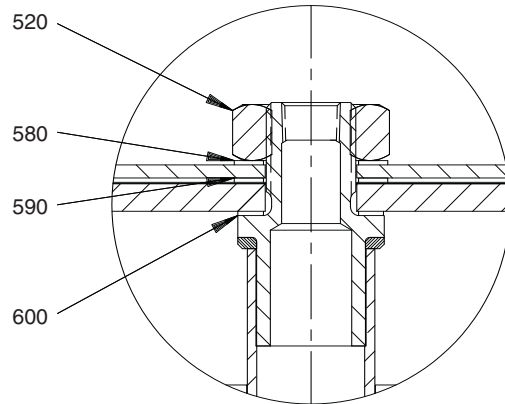

**Detail C**  
**Single Chamber Diaphragm Model Only**

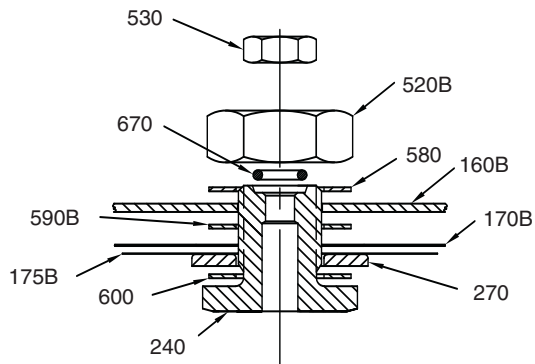

**Detail A**  
**Auxiliary Diaphragm Chamber Assembly**

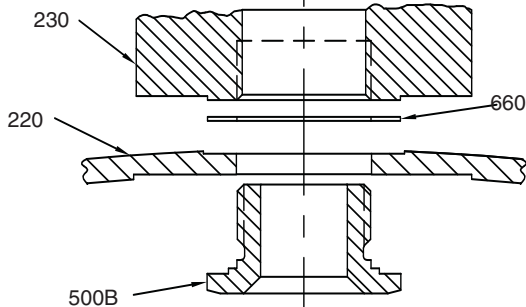

**Detail B**

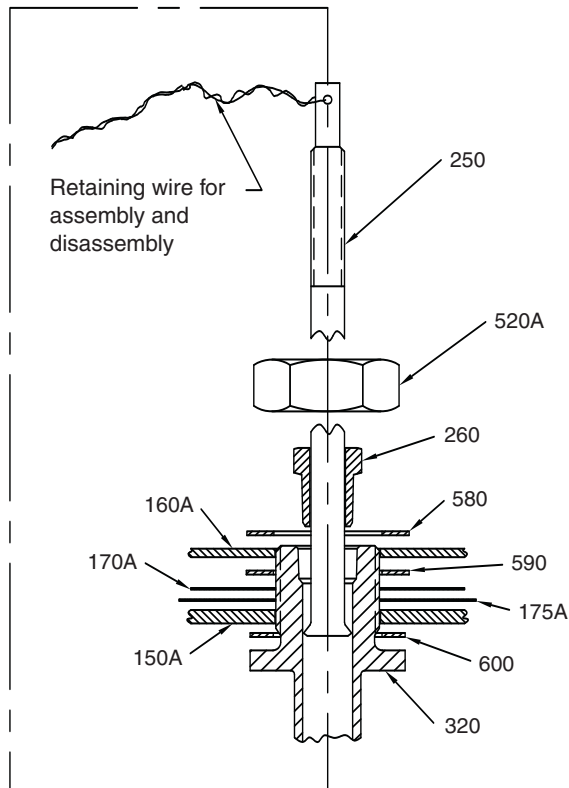

**Detail C**  
**Dual Chamber Diaphragm Model Only**

**Figure 6**

1. The contact surfaces must be clean, free from grease, and dry.
2. Remove the protective strip on the adhesive tape.
3. Lightly press in place as shown below.

**Upper Case(s) and Top of Body**

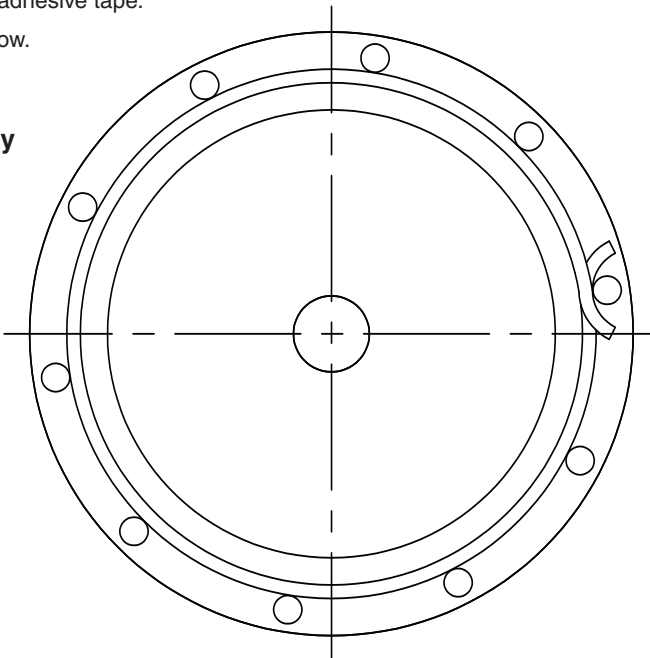

Put tape just inside of bolt holes, overlapping ends at a bolt hole. Put tape on top case only. Put tape on top surface of body. Do not put on lower case of mating pair.

**Nozzle**

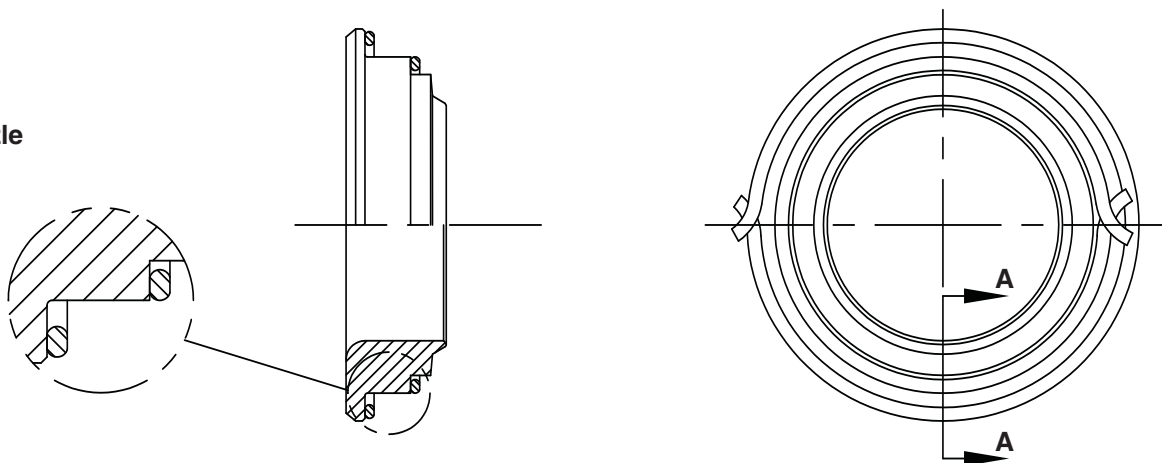

Place tape toward outer edge of each gasket ledge. Put overlaps on opposite sides. Use  $1/8$ " tape on 3" and 4" nozzles.  $3/16$ " tape on all cases and larger nozzles.

**Teflon® Tape (Gasket) Mounting Instructions**

**Figure 7**

### 3.0 Pilot Maintenance (Refer to Figures 8, 9, 10 and 11)

The pilots used for the 9290P Positive Relief Valve, for the 9290C Positive and Negative Pressure Relief Valve and the 9209V Negative Pressure Relief Valve are shown in Figures 8 and 9. Both pilots have the same construction, except for the location of the connections for the pressure sense. For either the positive or positive and negative pressure relief valve, the pilot controls only the positive pressure relief. The negative pressure relief is controlled by the weight of the parts that move in the main valve when it opens. For the negative pressure relief valve, the pilot controls the negative pressure relief.

#### 3.1 Disassembly

To facilitate assembly, place all parts removed in an orderly arrangement so the correct parts are assembled in the proper sequence.

- Remove cap (760) and adjusting screw (790) and adjusting screw seal (720) for vacuum pilot. Remove bonnet bolts (770), seals (700) for vacuum pilot, bonnet (200), spring (840) and spring washer (820).
- Loosen boost tube fitting on boost tube (320) at boost tube connector bolt (270). Refer to Detail B. Remove boost tube connector nut (300), washer (290), lower boost tube seal (590), seal retainer (280) for 93T pilot. Let these three parts slide down boost tube. Remove boost tube connector bolt (270), upper boost tube seal (590) and seal retainer (280) for 93T pilot.
- Remove case bolt nuts (260), washer (250) and bolts (240). Remove upper case (210).
- Refer to Detail A (for 93T pilot). Hold hex spacer (120) and remove spindle nut (750), washer (780), spring disc (830). Remove hex spacer (120), sense plate (150), sense diaphragm (520), sense spacer (140), boost plate (160), ring spacer (230), boost diaphragm (510), spindle gasket (680), boost spacer (130), spindle seal (660).
- Refer to Detail A (for 93 pilot). Hold hex spacer (120) and remove spindle nut (750), washer (780), spring disc (830). Remove hex spacer (120), sense plate (150), sense diaphragm (510), sense spacer (140), boost plate (160), ring spacer (230), boost diaphragm (510), check plate (560), boost spacer (130), spindle seal (660).
- Remove boost tube (320) from body (100) and lower boost tube seal (590 or 600) from boost tube (320).
- Remove spindle diaphragm (500) and gasket (690) for 93T pilot and spindle/disc assembly (550) from body (100).
- Remove spindle diaphragm plate (170) and shim washer(s) (490) from spindle/seat assembly (550). **NOTE: Shim washer(s) may not always be used in assembly (550).**
- Refer to Detail A. For the 93T pilot seat assembly, remove the retainer ring (430) and seat retainer (420) from the spindle/disc assembly (550). Remove the seat (570).
- Remove blowdown bushing (390) and blowdown seal (630) from body (100).

**NOTE: The blowdown screw retainer (380) is a loose fit on the blowdown adjustment screw (350). Be prepared to catch it when the bushing (390) is removed from the body (100).**

- Loosen the blowdown screw locknut (370) and remove the blowdown adjusting screw (350) and seal (630) from the bushing (390).
- Remove the vent (800) from the body (100). **NOTE: It is not necessary to remove the filter screen (400) or nozzle (110) from the body (100).**
- Clean all parts and replace all soft goods. The spindle/seat assembly (550) is factory assembled and must be replaced as a unit. If the nozzle (110) is nicked or scratched, it should be replaced. To remove it, use a deep socket.

### 3.2 Assembly

- Assemble the pilot in the reverse order of disassembly. Lubricate all threads and the end of the pressure adjustment screw (790) that bears against the spring washer with Dow Corning No. 33 silicone grease or equivalent. **NOTE: For oxygen service valves, use only lubricants suitable for this service, such as Fluorolube LG-160.**
- Observe the following items during assembly.
- Place the shim washer(s) (490) and spindle diaphragm plate (170) on the spindle assembly (550) and place the assembly in the body (100).
- Lay a straight edge across the body (100) and check the gap between the straight edge and body (100) or between the straight edge and the spindle diaphragm plate (170). Add or remove shim(s) (490) as required to make the top of the spindle diaphragm plate (170) even with the top of the body (100).
- Align the spindle diaphragm (500) holes with all the holes in the body (100). For 93T pilots, one case/body basket (690) is used on each side of the diaphragm.
- Align the small hole in the lower diaphragm case (220) with the hole in the spindle diaphragm, gaskets and body.
- Refer to Detail A: for the 93T pilot, spindle gaskets (680) are used on each end of the boost spacer (130) and the sense spacer (140).
- Refer to Figure 9 or 10. For the 93 pilot, one diaphragm gasket (650) is used on each side of the spacer ring. For the 93T pilot, one diaphragm gasket is used on each side of the boost diaphragm (510) and sense diaphragm (510).  
**NOTE: One of the diaphragm gaskets for the 93T has a smaller I.D. This one is used between the sense diaphragm and upper case (210).**
- Align the case bolt holes in the sense and boost diaphragms (510) with the holes in the lower case (220) and spacer ring (230) before the spindle nut (750) is tightened. Use the case bolts (240) to keep the holes aligned when the spindle nut is tightened.  
**NOTE: Do not tighten spindle nut too much. Overtightening will damage the diaphragms. Hold the hex spacer (120) when tightening the spindle nut (750) to prevent the spindle from turning.**

## Pilot Type 93/93T Parts List

Item	Description
100	Body
110	Nozzle
120	Spacer - Hex
130	Spacer - Boost
140	Spacer - Sense
150	Sense Plate
160	Plate - Boost
170	Spacer - Spindle
180	Plate - Diaphragm Case (93T only)
190	Pressure Adjustment Lock Nut
200	Bonnet Assy. (Items 450 and 710 are Part of this Assy.)
210	Diaphragm Case Upper
220	Diaphragm Case Lower
230	Ring - Spacer
240	Case Bolt
250	Case Washer - Lock
260	Case Nut - Hex
270	Connector - Boost Tube
280	Seal - Retainer (93T only)
290	Washer - Flat
300	Nut - Hex
310	Nut - Connector
320	Tube - Boost
330	Connector - Straight
340	Bolt - Body
350	Needle - Blowdown Adjustment
370	Blowdown Nut
380	Blowdown Retainer
390	Blowdown Bushing
400	Screen - Filter
410	Pin - Spiral (93T only)
420	Seat - Retainer (93T only)
430	Ring - Retainer (93T only)
440	Nut - Swage
450	Insert - Bonnet (Part of Item 200 Assembly)
460	Wire
470	Seal - 1/2" Dia.

## Pilot Type 93/93T Parts List

Item	Description
490	Washer - Shim (For Stack Height only)
500	Diaphragm - Spindle
510	Diaphragm - Sense/Boost
520	Diaphragm - Sense (93T only)
550	Spindle
560	Plate - Check
570	Seat
580	Gasket - Bonnet
590	Seal - Boost Tube
600	Seal - Thread
610	Seal - Body Bolt
620	Seal - Blowdown
630	Seal - Bushing
640	Gasket - Case
650	Gasket - Diaphragm
660	Seal - Spindle
670	Gasket - Sense (93T only)
680	Gasket - Spindle (93T only)
690	Gasket - Spindle Diaphragm (only Used if Item 500 is Teflon®)
700	Seal - Bonnet Bolt (Vacuum only)
710	Seal - Bonnet Insert (Part of Item 200 Assy.-Vacuum only)
720	Seal - Adj. Screw (Vacuum only)
730	Base - Seat (93T only)
740	Ball
750	Nut - Hex
760	Cap
770	Bolt - Bonnet
780	Washer - Lock
790	Pressure Adjustment Screw
800	Vent - Body (Dependent on Type of Assy.)
810	Vent - Bonnet (Dependent on Type of Assy.)
820	Washer - Spring
830	Disc - Spring
840	Spring

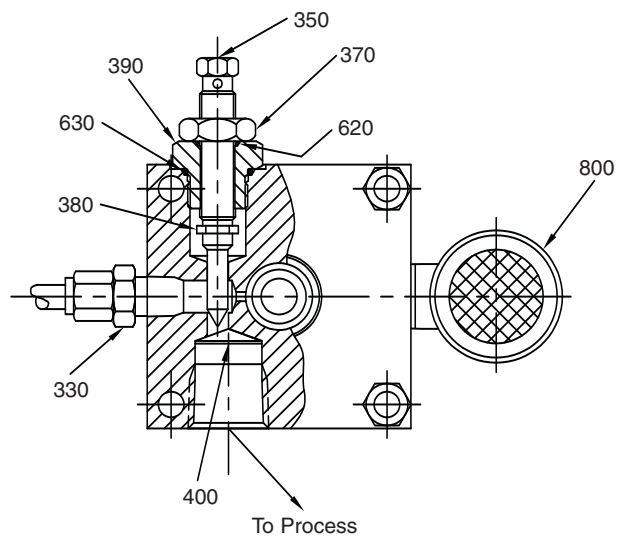
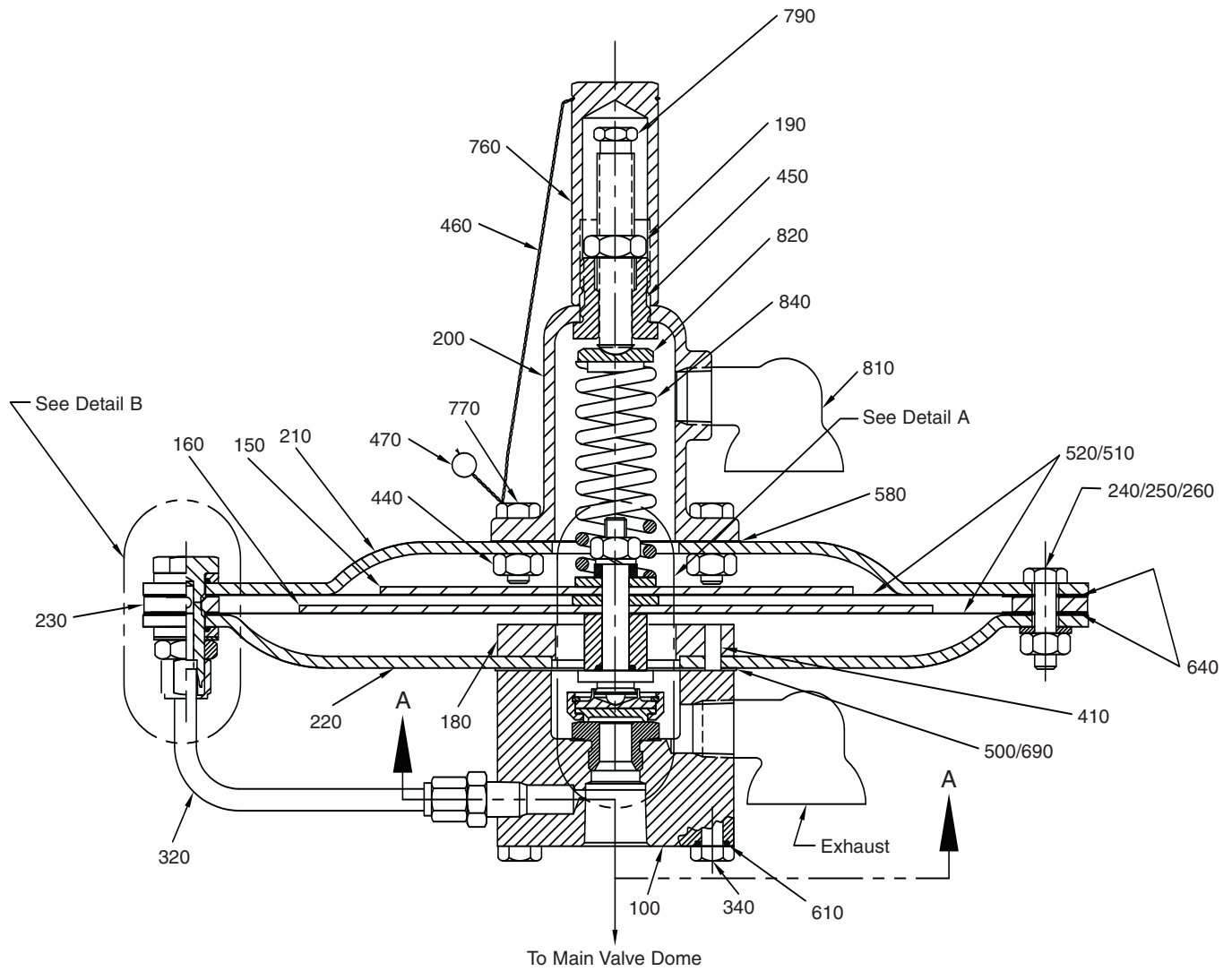

View A-A

Type 93 Pressure Pilot

Figure 8

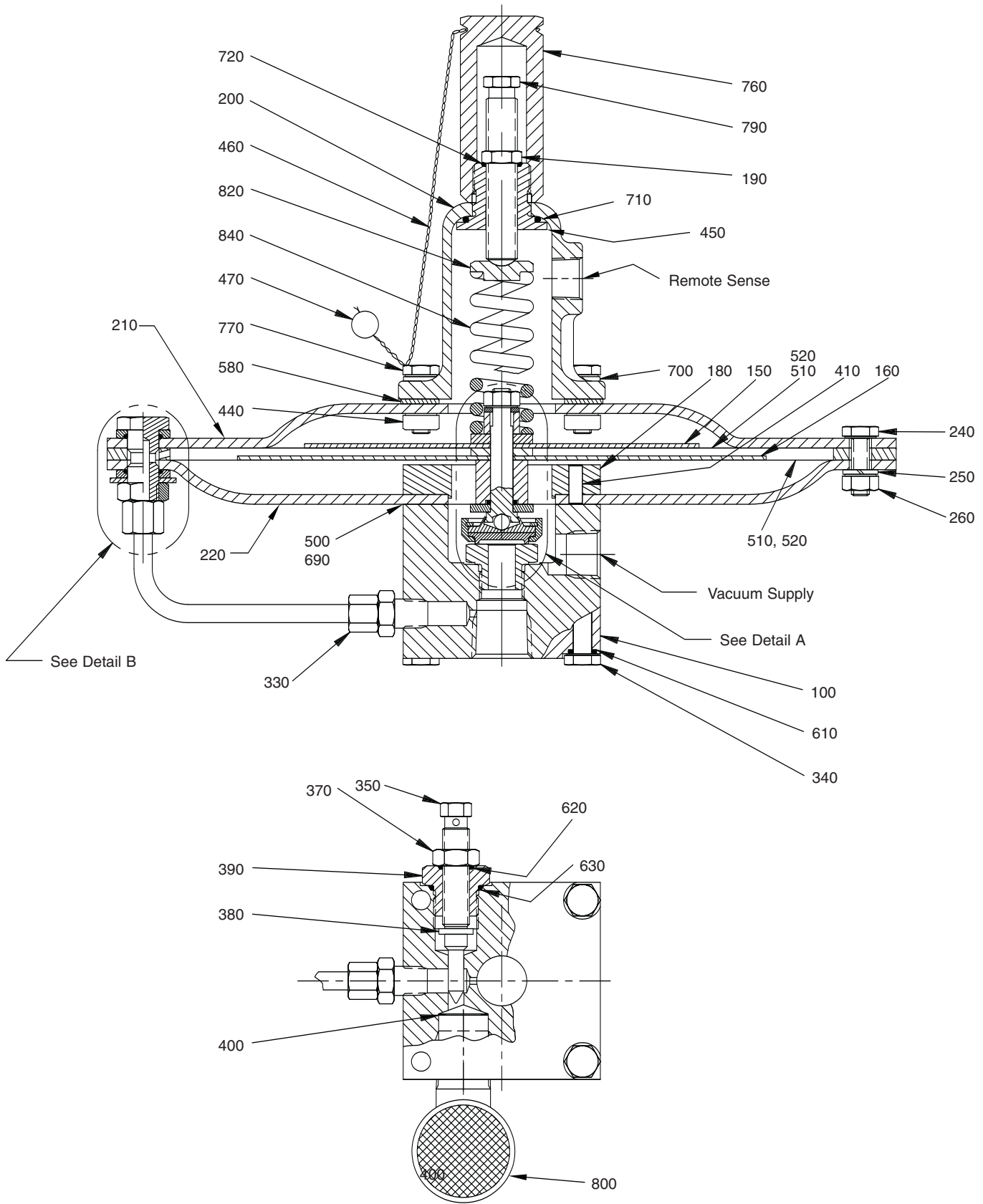

**Type 93 Pressure Pilot**  
**Figure 9**

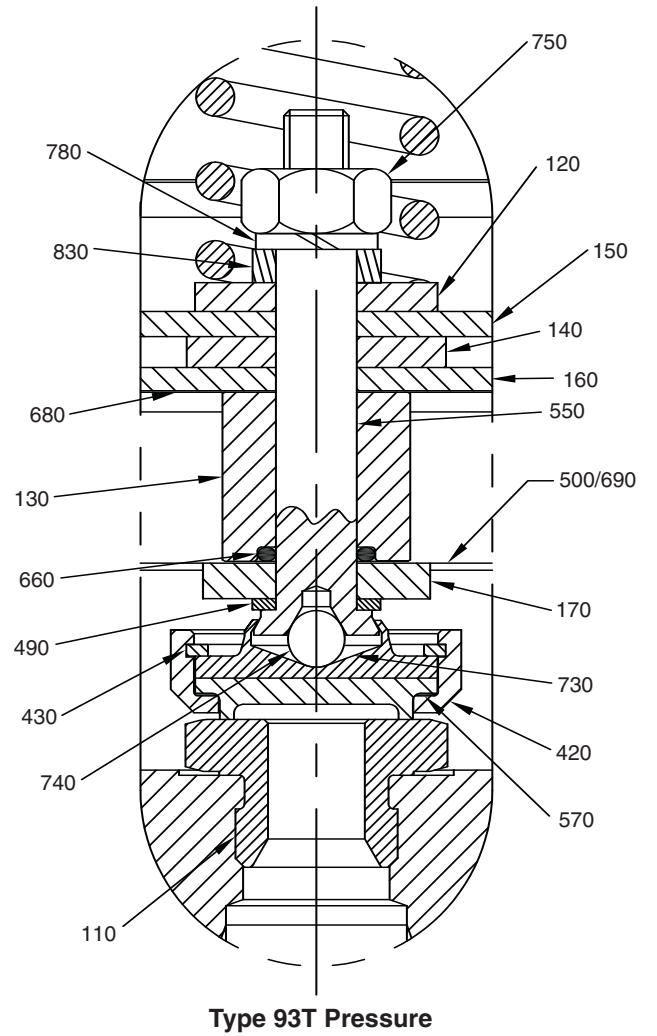
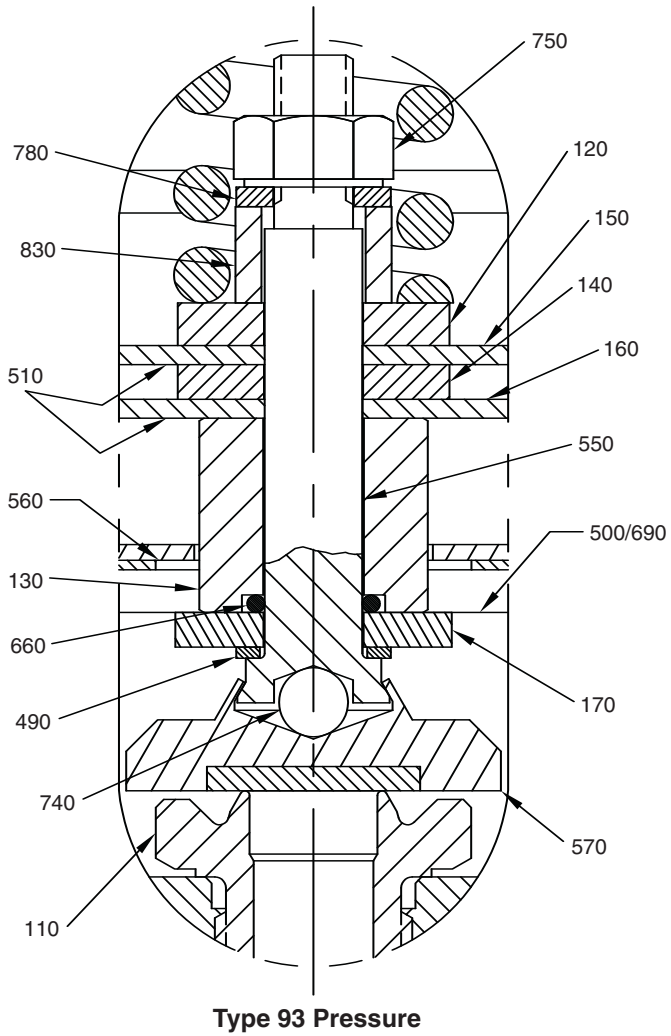

**Detail A  
 Figure 10**

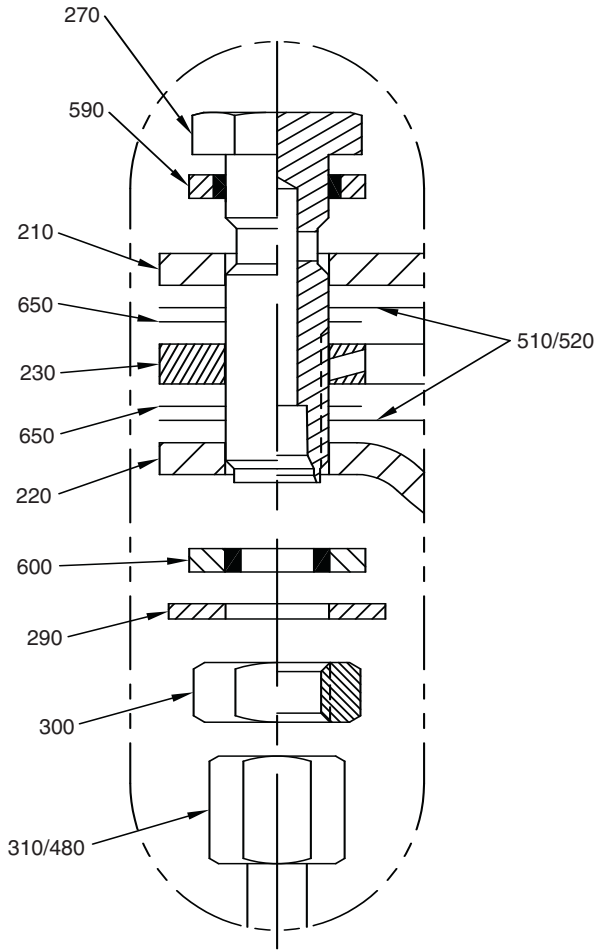

**Type 93**

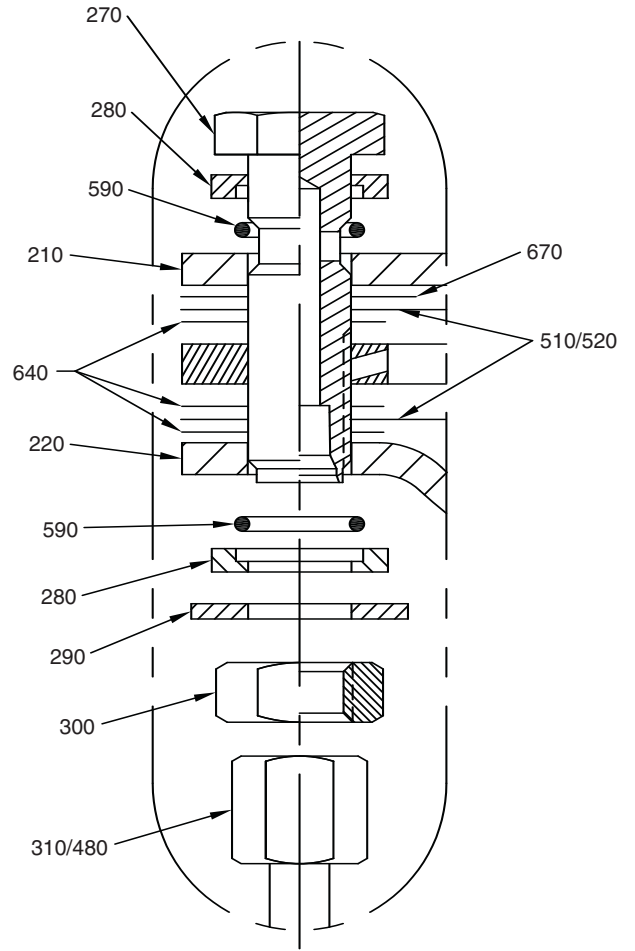

**Type 93T**

**Detail B  
 Figure 11**

## 4.0 Pilot Adjustment

### 4.1 Set Pressure

To adjust the set pressure, a test set-up similar to that shown in Figure 12 should be used. The set pressure adjustment screw (790) should be turned IN most of the way. Increase the supply pressure to nameplate setting and slowly back this adjustment screw out until flow through the pilot exhaust begins. Continue to back screw out until the dome pressure is 70% of the supply pressure.

### 4.2 Reseat Pressure

This adjustment is obtained by turning the blowdown adjusting screw (350) clockwise (in) to decrease the reseat pressure, counterclockwise (out) to increase the reseat pressure. A small interaction between set pressure and reseat pressure adjustments will occur, therefore it may be necessary to readjust the set pressure after setting reseat pressure.

**NOTE: If the blowdown adjusting screw has been moved or turned to either extreme, positioning it midway will aid in obtaining the correct reseat pressure. There are approximately 7 to 8 turns to obtain full travel of the adjustment. Midway from either end should produce a blowdown for snap action. For modulating pilot action, back the adjustment screw out (counterclockwise).**

### 4.3 Range of Adjustment

All pilots can be adjusted  $\pm 10\%$  of the set pressure value stamped on the nameplate with the spring supplied with the pilot. Consult the factory to determine if the spring in the pilot can be adjusted more.

### 4.4 Definitions

**Set Pressure** is defined as that supply pressure when the dome pressure is 70% of the supply pressure.

**Crack Pressure** is defined as the supply pressure where gas flow begins at the pilot outlet.

**Reseat Pressure** is defined as that supply pressure when the dome pressure is 75% of the supply pressure.

**Snap Action** is defined where dome pressure decreases rapidly with no increase in supply pressure.

**Modulating Action** is defined where dome pressure decreases slowly and may require some increase in supply pressure to obtain this decrease.

### 4.5 Adjustment Tolerances

Pilot Action	Set Pressure	Set Pressure Tolerance	Crack Pressure % Set	Reseat Pressure % Set
Snap	4"WC to 7"WC	$\pm .2$ "WC	75	90 $\pm$ 1
Snap	7"WC to 1.0 psig	$\pm 3\%$	90	90 $\pm$ 1
Snap	above 1.0 psig	$\pm 3\%$	95	92 $\pm$ 1
Snap	4"WC to -7"WC	$\pm .2$ "WC	75	90 $\pm$ 1
Snap	-7"WC to -1.0 psig	$\pm 3\%$	90	90 $\pm$ 1
Snap	-1 psig to -14.7 psig	$\pm 3\%$	95	92 $\pm$ 1
Modulating	4"WC to 7"WC	$\pm .2$ "WC	75	100
Modulating	7"WC to 1.0 psig	$\pm 3\%$	90	100
Modulating	above 1.0 psig	$\pm 3\%$	95	100
Modulating	-4"WC to -7"WC	$\pm .2$ "WC	75	100
Modulating	-7"WC to -1.0 psig	$\pm 3\%$	90	100
Modulating	-1.0 psig to -14.7 psig	$\pm 3\%$	95	100

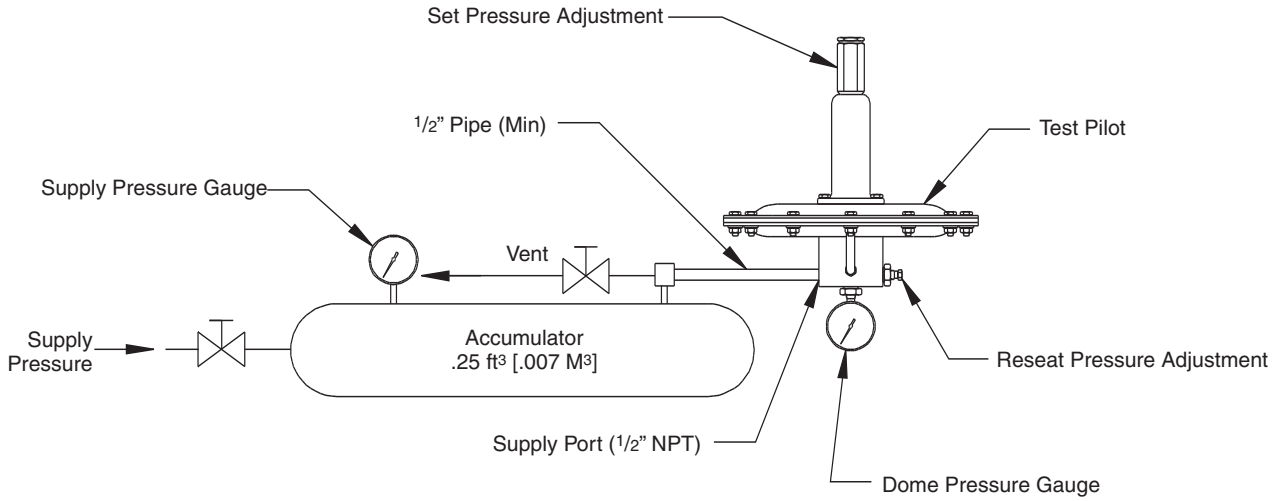

**Positive pressure pilot**

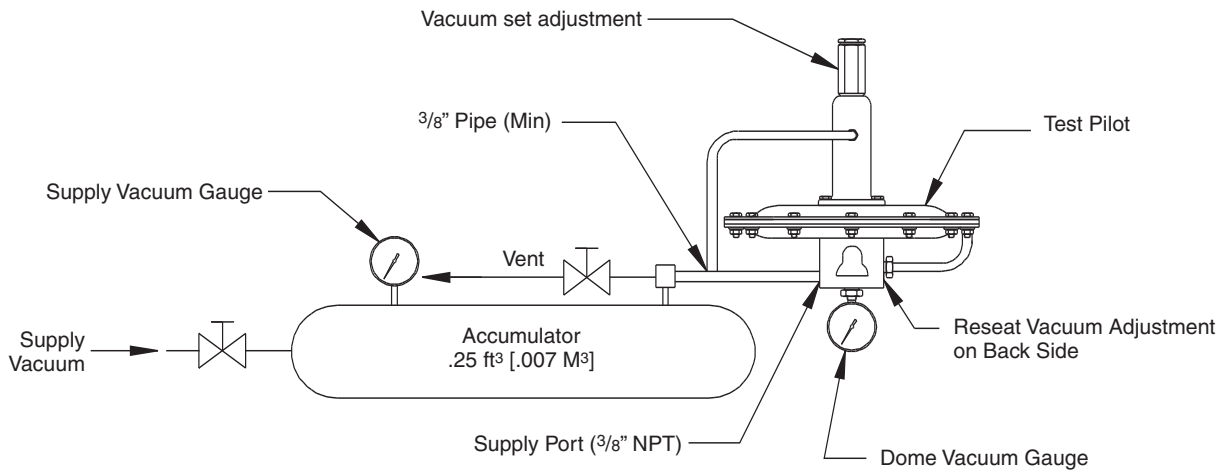

**Negative Vacuum Pressure Pilot**

**Figure 12**

## 5.0 Leak Testing the Assembly

### 5.1 General

The complete valve assembly should be leak tested for internal and external leaks using a pressure equal to 30% and 90% of set.

### 5.2 Internal Leak Test

Spray leak test solution around nozzle/seat area to locate a leak. Seat leakage may be caused by a damaged nozzle seat or seat film. Pilot internal leakage may be checked by blocking one pilot exhaust vent and using a leak test bubble bottle on the other.

### 5.3 External Leak Test

Apply leak test solution to all joints and seals. Tighten bolts or fittings as required.

## 6.0 Field Test Instructions-Positive Pressure Pilot

An optional field test accessory is available for checking the positive set pressure without removing the valve from service. The field test accessory consists of a 3-way ball valve to allow the pilot to sense pressure from either the process or from the test gas source.

A standard bottle of nitrogen equipped with a pressure regulator, block valve, pressure gage, and convenient length of high pressure flexible hose is recommended for testing. A set-up similar to that shown in Figure 13 should be used. Such a test kit is available from Anderson Greenwood under the part number 04.4812.001 plus additional dash numbers for the pressure gauges required.

### Field Test Procedure

- A. Connect gas bottle as shown in Figure 13.
- B. Close vent valve "C".
- C. Open block valve "B" to supply regulator (regulator pressure should be set at zero).
- D. Connect bubble tester bottle to pilot exhaust vent.
- E. Increase pressure at field test port to slightly above tank pressure by slowly increasing regulated pressure.
- F. Open field test valve "A" and slowly increase regulator pressure until bubbles are seen in the bottle. That pressure will be within 10 percent of the set pressure. For pilots adjusted for snap action, the main vent seat will open at set pressure if tank pressure is present. If it is not, a sudden increase in pilot exhaust flow will be observed at set pressure.
- G. To remove the test set-up, close valves "A" and "B" and open valve "C".

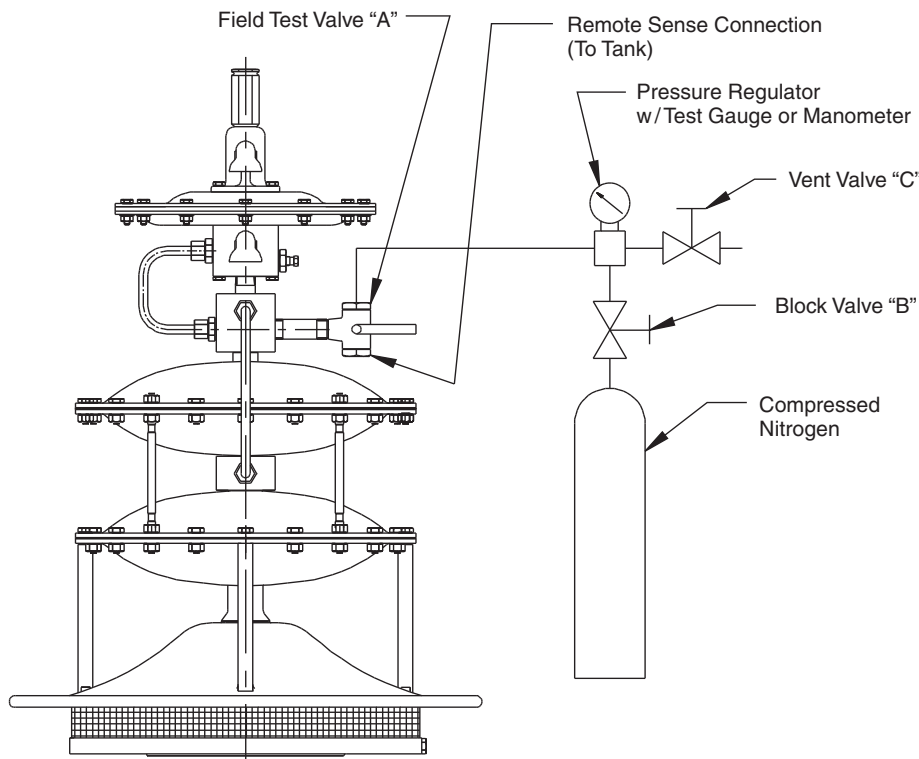

Figure 13

## 7.0 Repair Kits

Soft goods repair kits contain all the diaphragms, seals, and seats to repair a valve. To order a kit, specify the base number and select the last three digits from the following tables. To make sure the correct repair kit is received, the order should specify the valve model and serial number. For chloride rich environments, the bolts in the main valve and pilot exposed to the environment should be replaced during routine maintenance or at least every five years.

### Pilot Repair Kit (Kit base Number 06.0235.XXX)

Kit Type	Description Pressure or Vacuum	Material	Dash Number	
			Pressure	Vacuum
Soft Goods (93 Pilot)	4" WC thru 5 psig	BUNA	133	152
Soft Goods (93 Pilot)	4" WC thru 5 psig	Viton®	134	153
Soft Goods (93 Pilot)	4" WC thru 5 psig	EPR	135	154
Soft Goods (93 Pilot)	4" WC thru 5 psig	BUNA <sup>(1)</sup>	136	155
Soft Goods (93 Pilot)	4" WC thru 5 psig	Viton® <sup>(1)</sup>	137	156
Soft Goods (93 Pilot)	4" WC thru 5 psig	EPR <sup>(1)</sup>	138	157
Bolt (93 Pilot)	4" WC thru 5 psig	SST	287	287
Soft Goods (93T Pilot)	4" WC thru 5 psig	Teflon®	139	158
Bolt (93T Pilot)	4" WC thru 5 psig	SST	287	287

(1) Teflon® diaphragms

### Main Valve Repair Kit Type 9290P or 9209V - Single Chamber Diaphragm (Kit Base Number 06.0235.XXX)

Kit Type	Internals	Materials	2"	3"	4"	6"	8"	10"	12"
Soft Goods	Alum	Teflon®	305	307	309	311	313	315	317
Soft Goods	SST	Teflon®	482	484	486	488	490	492	494
Bolt	Alum	SST	280	281	282	283	284	285	286
Bolt	SST	SST	431	432	433	434	435	436	437

### Type 9290C - Dual Chamber Diaphragm (Kit Base Number 06.0235.XXX)

Kit Type	Internals	Materials	2"	3"	4"	6"	8"	10"	12"
Soft Goods	Alum	Teflon®/Kalrez®	291	293	295	297	299	301	303
Soft Goods	SST	Teflon®/Kalrez®	468	470	472	474	476	478	480
Bolt	Alum	SST	273	274	275	276	277	278	279
Bolt	SST	SST	417	418	419	420	421	422	423

### Accessory Repair Kit (Kit base Number 06.0235.XXX)

Accessory	Kit Type	Material	Dash Number
Diaphragm Check	Soft Goods	Teflon®	144
Diaphragm Check	Bolt	SST	414

Viton® is a registered trademark of E.I. du Pont de Nemours Company.  
Kalrez® is a registered trademark of DuPont Dow Elastomers.

## 8.0 Accessory Repair

### 8.1 Check Valve (Figure 14)

The check valves used on the Dual Pilot, Backflow Preventer, and Field Test with backflow preventer consist of an upper body, a lower body, and a diaphragm.

The check valve diaphragm is the only part that should require servicing. If the diaphragm is to be replaced, care should be taken not to scratch or distort it in the center nozzle sealing area. When reassembling the check valve, uniformly tighten the body bolts, first one side, then the opposite side until all are tight. **DO NOT OVERTIGHTEN** bolts as this will distort the diaphragm and cause leakage.

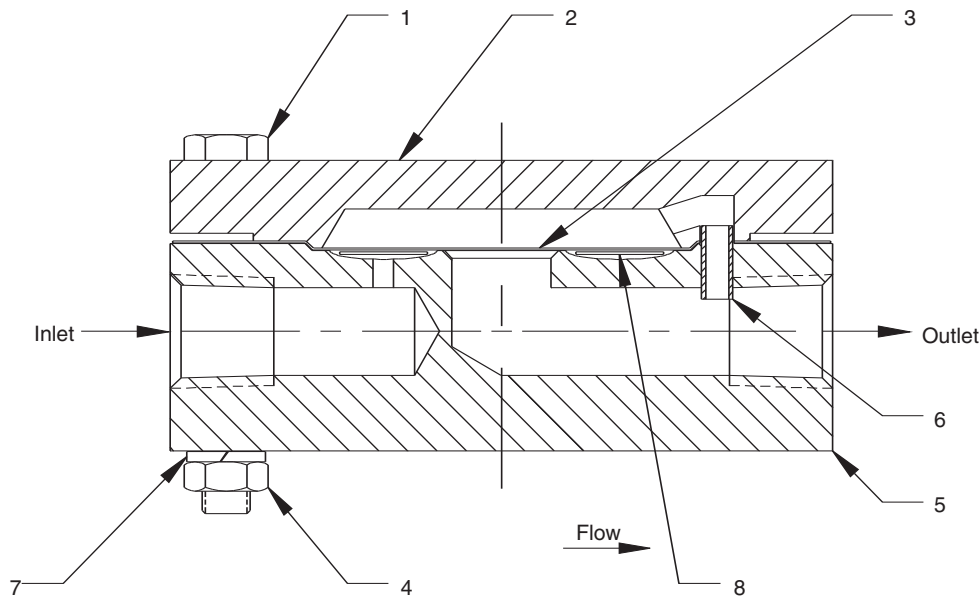

#### Parts

Item	Description
1	Hex Head Cap Screw
2	Upper Body
3	Diaphragm
5	Lower Body
6	Spring Pin
7	Lockwasher
8	Diaphragm Support Washer

Figure 14

[www.tycoflowcontrol.com](http://www.tycoflowcontrol.com)

Tyco Flow Control (TFC) provides the information herein in good faith but makes no representation as to its comprehensiveness or accuracy. This IOM is intended only as a guide to TFC products and services. Individuals using this IOM must exercise their independent judgment in evaluating product selection and determining product appropriateness for their particular purpose and system requirements. TFC MAKES NO REPRESENTATIONS OR WARRANTIES, EITHER EXPRESS OR IMPLIED, INCLUDING WITHOUT LIMITATION ANY WARRANTIES OF MERCHANTABILITY OR FITNESS FOR A PARTICULAR PURPOSE WITH RESPECT TO THE INFORMATION SET FORTH HEREIN OR THE PRODUCT(S) TO WHICH THE INFORMATION REFERS. ACCORDINGLY, TFC WILL NOT BE RESPONSIBLE FOR DAMAGES (OF ANY KIND OR NATURE, INCLUDING INCIDENTAL, INDIRECT, OR CONSEQUENTIAL DAMAGES) RESULTING FROM THE USE OF OR RELIANCE UPON THIS INFORMATION. Patents and Patents Pending in the U.S. and foreign countries. Tyco reserves the right to change product designs and specifications without notice.

Engineering Doc. #05.9040.174 Rev. F