

Pilot Operated Safety Relief Valves (POSRV)

ANDERSON GREENWOOD

Before installation these instructions must be fully read and understood.

The intent of these instructions is to acquaint the user with the storage, installation and operation of this product. **Please read these instructions carefully before installation.**

Safety Precautions

When the pressure relief valve is under pressure never place any part of your body near the pilot exhaust nor the outlet of the main valve.

The main valve outlet should be piped or vented to a safe location.

Always wear proper safety gear to protect head, eyes, ears, etc. anytime you are near pressurized valves.

Never attempt to remove the pressure relief valve from a system that is pressurized.

Never make adjustments to or perform maintenance on the pressure relief valve while in service unless the valve is isolated from the system pressure.

If not properly isolated from the system pressure, the pressure relief valve may inadvertently open resulting in serious injury.

Remove the pressure relief valve prior to performing any pressure testing of the system.

The safety of lives and property often depends on the proper operation of the pressure relief valve. The valve must be maintained according to appropriate instructions and must be periodically tested and reconditioned to ensure correct function.

Warning

Removal of the seal wires in an attempt to adjust and/or repair this product by unauthorized or unqualified persons voids the product warranty and may cause damage to equipment and serious injury or death to persons.

The product is a safety related component intended for use in critical applications. The improper application, installation or maintenance of the product or the use of parts or components not manufactured by Anderson Greenwood may result in a failure of the product.

Any installation, maintenance, adjustment, test, etc. performed on the Product must be done in accordance with the requirements of all applicable Anderson Greenwood Procedures and Instructions as well as applicable National and International Codes and Standards.

Storage and Handling

Pressure relief valve performance may be adversely affected if the valve is stored for an extended period without proper protection. Rough handling and dirt may damage, deform, or cause misalignment of valve parts and may alter the pressure setting and adversely affect valve performance and seat tightness. It is recommended that the valve be stored in the original shipping container in a warehouse or as a minimum on a dry surface with a protective covering until installation. Inlet and outlet protectors should remain in place until the valve is ready to be installed in the system.

Table of Contents

1.0	General Valve Description.....	2
2.0	Accessory Maintenance.....	3
3.0	Main Valve Maintenance	4
4.0	Pilot Maintenance	5
5.0	Pilot Set Pressure Adjustment	8
6.0	Pilot Set Pressure Field Test Procedure	9
7.0	Valve Diagnosis Guide	10
8.0	Soft Goods Repair Kits	10

Pilot Operated Safety Relief Valves (POSRV)

1.0 General Valve Description (Refer to Figure 1)

The Anderson Greenwood Type 95 Valve consists of a main valve and pilot. The main valve has an unbalanced piston with O-ring seat. Tank pressure is applied to the top of the piston by means of the pilot. The area of the top of the piston is larger than the bottom and the valve remains closed.

When the tank pressure increases to the set pressure of the pilot, the pilot opens and vents the pressure from the top of the piston. The force acting on the bottom of the piston is now greater than that acting on the top and the valve opens.

When the tank pressure decreases to the closing pressure of the pilot, the pilot closes and tank pressure is directed to the top of the piston. The force acting on the top of the piston is now greater than the force on the bottom and the valve closes.

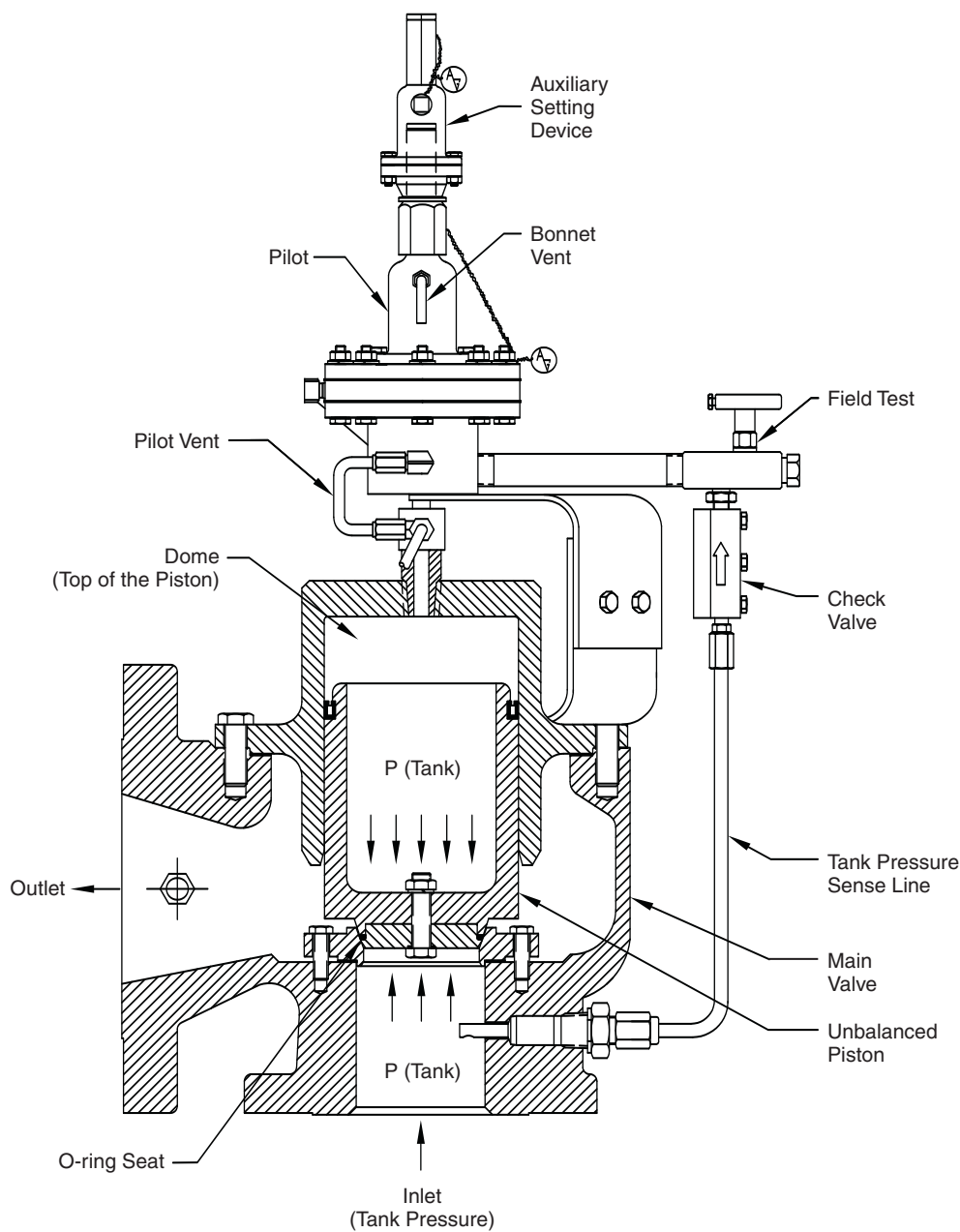

Figure 1

Pilot Operated Safety Relief Valves (POSRV)

Item	Description
* 1	Auxiliary Setting Device
2	Supply Tubing
3	Pilot Exhaust Tubing
4	Pilot Bracket Bolt
* 5	Pilot
6	Pipe Nipple
7	Field Test Hand Valve
8	Field Test Plug
9	Connector
10	Check Valve
11	Connector
12	Connector
13	Close Tee
15	Check Valve
16	Connector
17	Connector
18	Pipe Plug
19	Body Bolt
20	Lock Washer
21	Upper Body
* 22	Diaphragm
* 23	Washer
24	Spring Pin
25	Lower Body
26	Body
27	Spring
28	Ball
29	O-ring
⁽¹⁾ 30	Gasket

* Recommended spare parts for repairs

2.0 Accessory Maintenance (Refer to Figure 2)

The accessories used on the Type 95 are the Auxiliary Setter, Field Test and Backflow Preventer. The Field Test and Backflow Preventer are always used; the Auxiliary Setter is optional.

Only the Backflow Preventer, which consists of one ⁽²⁾ diaphragm type check valve and a ball check valve requires maintenance. Normal maintenance is to clean the check valves and replace the diaphragm, washer, gasket, ⁽¹⁾ and O-ring.

When replacing the diaphragm, care should be taken not to damage the diaphragm. To assemble the diaphragm type valve, uniformly tighten the body bolts, first one side, then the opposite side. Do not overtighten the bolts as this will distort the diaphragm and cause leakage.

NOTES: ⁽¹⁾ Gasket used on some check valves. If check valve has gasket, use gasket supplied in repair kit - otherwise discard kit gasket.

⁽²⁾ Some earlier model valves use two diaphragm check valves and no ball check valve.

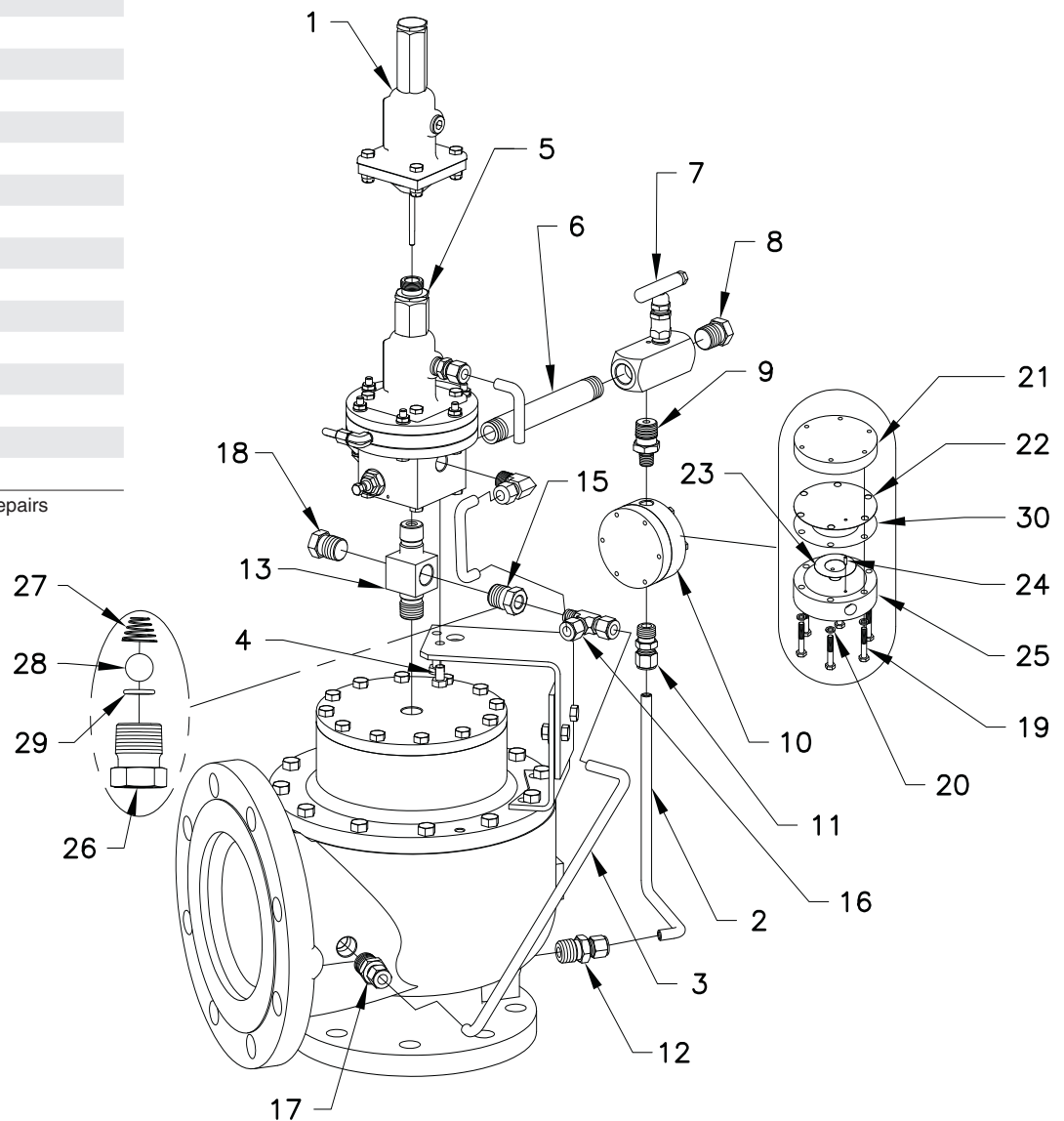

**Auxiliary Setter, with Field Test and Backflow Preventer
Indexed in Order of Disassembly**

Figure 2

Pilot Operated Safety Relief Valves (POSRV)

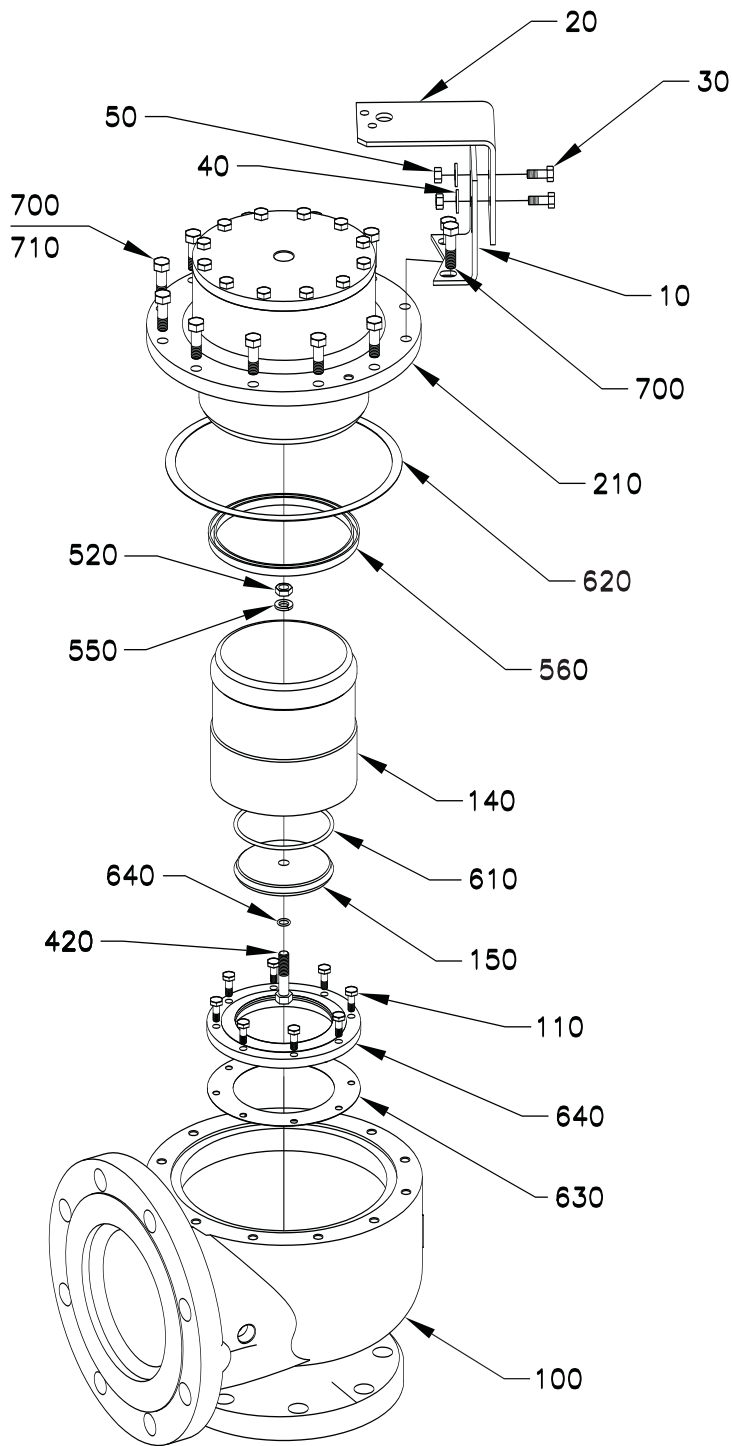

Indexed in Order of Disassembly

Figure 3

3.0 Main Valve Maintenance (Refer to Figure 3)

Normal valve maintenance will be to only clean the parts. It may also be necessary to replace the seat. The piston seal should not need to be replaced. If the piston seal is removed, a new seal must be installed.

The piston can be removed from the cap/liner by pulling the piston out or by pushing it out with a rod through the hole in the top of the cap/liner.

No lubricant is required on the piston seal. A small amount of thread sealant should be used on the pipe threads to prevent leakage. Teflon® tape is recommended.

The piston should be assembled to the cap/liner and the two parts should then be assembled to the valve body. The piston can be prevented from sliding out of the cap/liner during assembly by covering or plugging the hole in the top of the cap/liner.

For marine service, the bolts in the main valve and pilot exposed to the environment should be replaced during routine maintenance every five years.

Item	Description
10	Lower Bracket
20	Upper Bracket
30	Bracket Bolt
40	Washer
50	Hex Nut
100	Body
110	Screw
140	Piston
150	Seat Retainer
200	Washer (used on 6 x 8 only)
210	Cap/Liner
420	Bolt
460	Nozzle
520	Nut
550	Washer
* 560	Guide Seal
* 610	O-ring Seat
* 620	Cap Gasket
* 630	Nozzle Gasket
* 640	Washer
700	Cap Bolt - Hex
710	Cap Bolt - Eye ⁽¹⁾

* Recommended spare parts for repairs
(1) not shown – used on ≥ 4"

Refer to Page 10 for Soft Goods Repair Kits Part Numbers.

Pilot Operated Safety Relief Valves (POSRV)

4.0 Pilot Maintenance (Refer to Figure 4A)

Anderson Greenwood recommends the pilot be returned to the factory for repair or to be repaired by a factory serviceman in the field.

Normal maintenance is to completely disassemble the pilot and replace all the diaphragms, seals and seat. To facilitate assembly, place all parts removed in an orderly arrangement so that the correct parts are assembled in the proper sequence. No lubricants are required in the pilot. A small amount of thread sealant should be used on the pipe threads to prevent leakage. Teflon® tape is recommended.

Assembly is done in the reverse order of the disassembly. The following items should be observed when assembling the pilot:

- The round metal diaphragm is the sense diaphragm. The clear teflon diaphragm is the boost diaphragm.
- The holes in the spindle diaphragm must be aligned with all the holes in the body. The small hole in the lower case must be aligned with the hole in the body.
- Two of the six case bolts must be assembled through the holes in the lower case before it is attached to the body. After attachment there is insufficient clearance to do so.
- Tighten the spindle nut snugly but not excessively. Three diaphragms are sandwiched in the spindle/stack assembly and excessive tightening will damage them. Hold the hex spacer when torquing the spindle nut to prevent the stack from rotating.

After the pilot is assembled the set pressure must be adjusted. Refer to Section 5.0 for instructions.

Refer to Page 10 for Soft Goods Repair Kits Part Numbers.

For Figures 4A and 4B

Item	Description
100	Body
110	Nozzle
120	Hex Spacer
130	Boost Spacer
140	Sense Spacer
150	Sense Plate
160	Boost Plate
170	Spindle Spacer
190, 190A	Pressure Adjuster Lock Nut
200, 200A	Bonnet Assembly ⁽¹⁾
210	Upper Diaphragm Case
220	Lower Diaphragm Case
230	Spacer Ring
235A	Adapter
240	Case Bolt
250	Lock Washer
260	Hex Nut
320	Boost Tube
330	Connector Elbow
340	Body Bolt
350	Blowdown Needle
370	Hex Jam Nut

Item	Description
380	Retainer Plug
390	Blowdown Bushing
400	Filter Screen (not shown)
420	Retainer Seat
430	Retainer Ring
440A	Hex Nut
450	Bonnet Insert ⁽¹⁾
460	Wire (not shown)
470	Seal – 1/2" Diameter (not shown)
490	Washer Shim (for stack height)
500	Spindle Diaphragm*
510	Sense/Boost Diaphragm*
520	Sense Diaphragm*
550	Spindle
555A	Extension Rod
560	Check Plate
570	Seat
580, 580A	Bonnet Gasket*
610	Body Bolt Seal*
620	Blowdown Seal*
630	Bushing Seal*
640	Case Gasket*

Item	Description
660	Spindle Seal*
680	Spindle Gasket*
690	Spindle Diaphragm Gasket*
730	Seat Base – Type 95
740	Ball
750	Hex Nut
760, 760A	Cap
770, 770A	Bonnet Bolt
780	Lock Washer
790, 790A	Pressure Adjustment Screw
800	Vent – Body (not shown)
805A	Vent – Plug
810	Vent – Connector
815	Vent – Tube
820, 820A	Spring Washer
830, 830A	Spring Disc
840, 840A	Spring

A = Used in Auxiliary Setter

* Recommended spare parts for repairs
⁽¹⁾ Part of Item 200 Assembly

Pilot Operated Safety Relief Valves (POSRV)

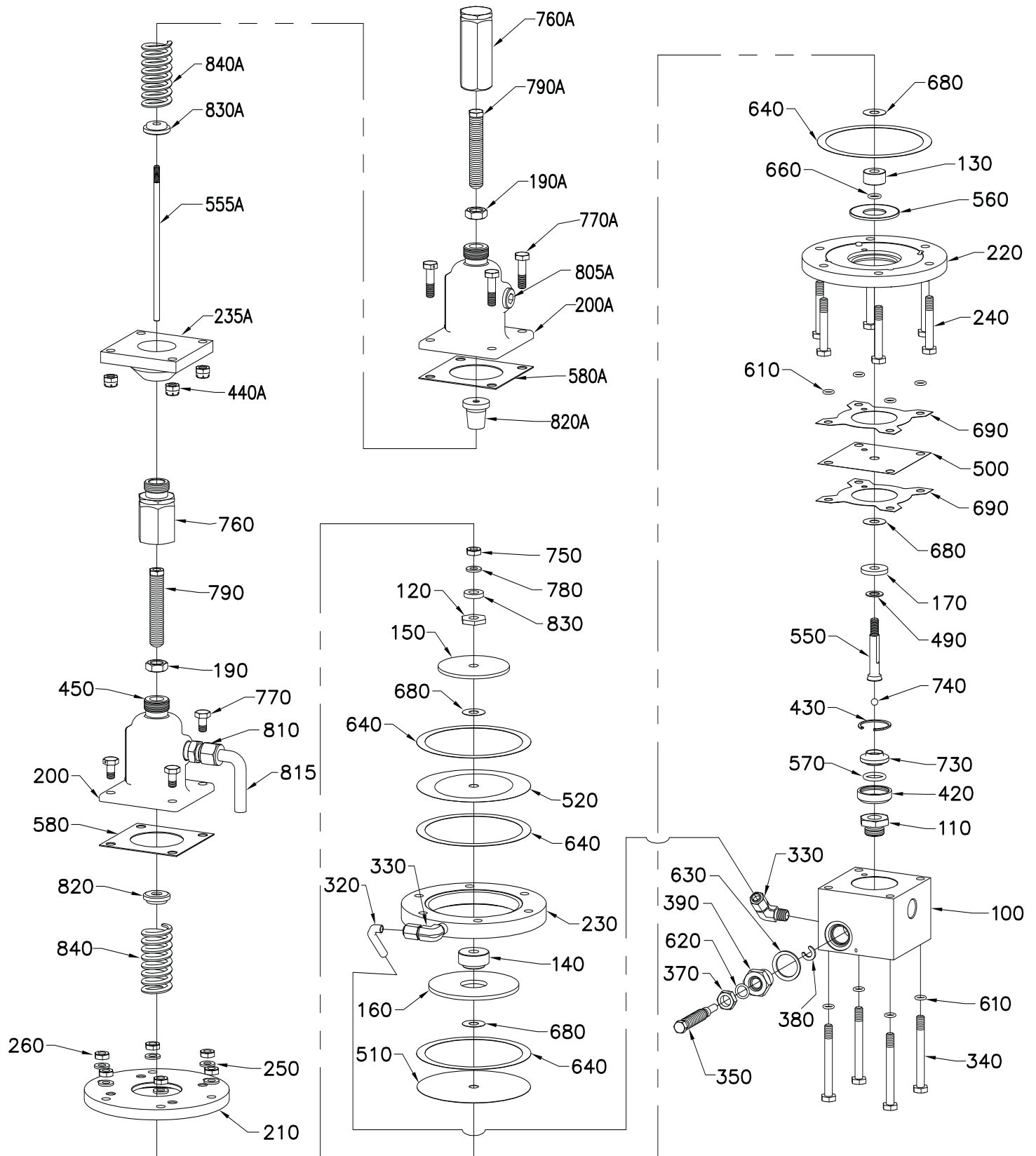

Type 95 Pilot with Auxiliary Setter

Figure 4A

Pilot Operated Safety Relief Valves (POSRV)

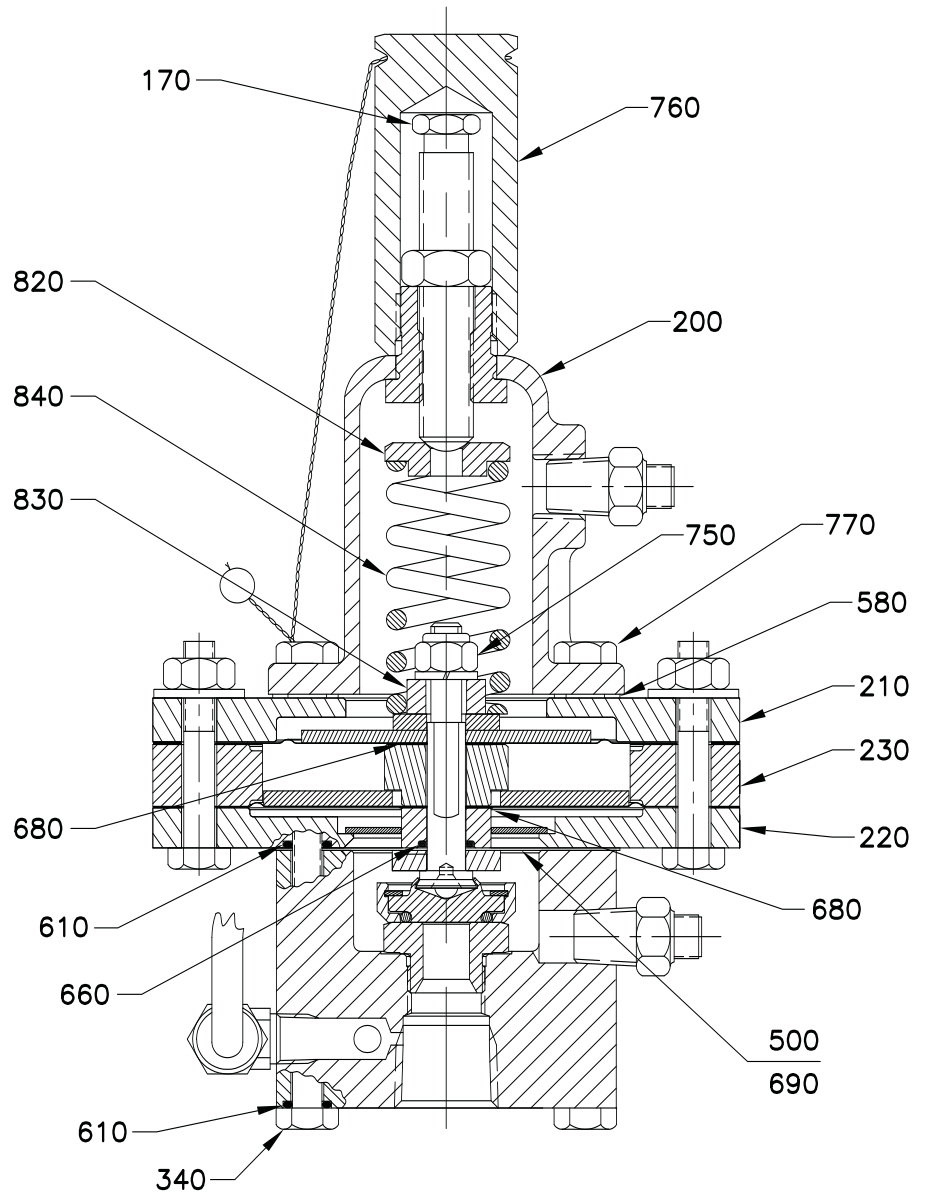

Figure 4B

Pilot Operated Safety Relief Valves (POSRV)

5.0 Pilot Set Pressure Adjustment (Refer to Figure 5)

To adjust the opening and closing pressure of the pilot after the pilot has been completely disassembled and reassembled, a test set-up similar to that shown in Figure 5 should be used.

- 5.1 Check the position of the blowdown adjustment screw. It should be turned half way in (approximately 5 turns).
- 5.2 With the pressure adjustment screw turned most of the way in, increase the supply pressure to the desired set pressure. Back the pressure adjustment screw out until the pilot "snaps" open. The dome pressure should decrease to 25% or less of the supply pressure.

When the pilot opens and flows, the supply pressure will decrease due to the pressure drop in the lines to the accumulator. The set pressure is the highest pressure recorded on the supply pressure gauge.

- 5.3 Decrease the supply pressure to the correct reseal pressure and back the blowdown adjustment screw out until the dome pressure "snaps" back. The supply pressure at which this occurs is the reseal pressure and it should be about 90% of the set pressure.

When the pilot reseats, the supply pressure will increase due to reduced flow through the supply line. The reseal pressure will be the lowest pressure read on the supply gauge. Tighten the jam nut after each setting for accurate readings.

Recycle the pilot valve to verify the settings. A small interaction between the blowdown adjustment and the pressure adjustment will occur.

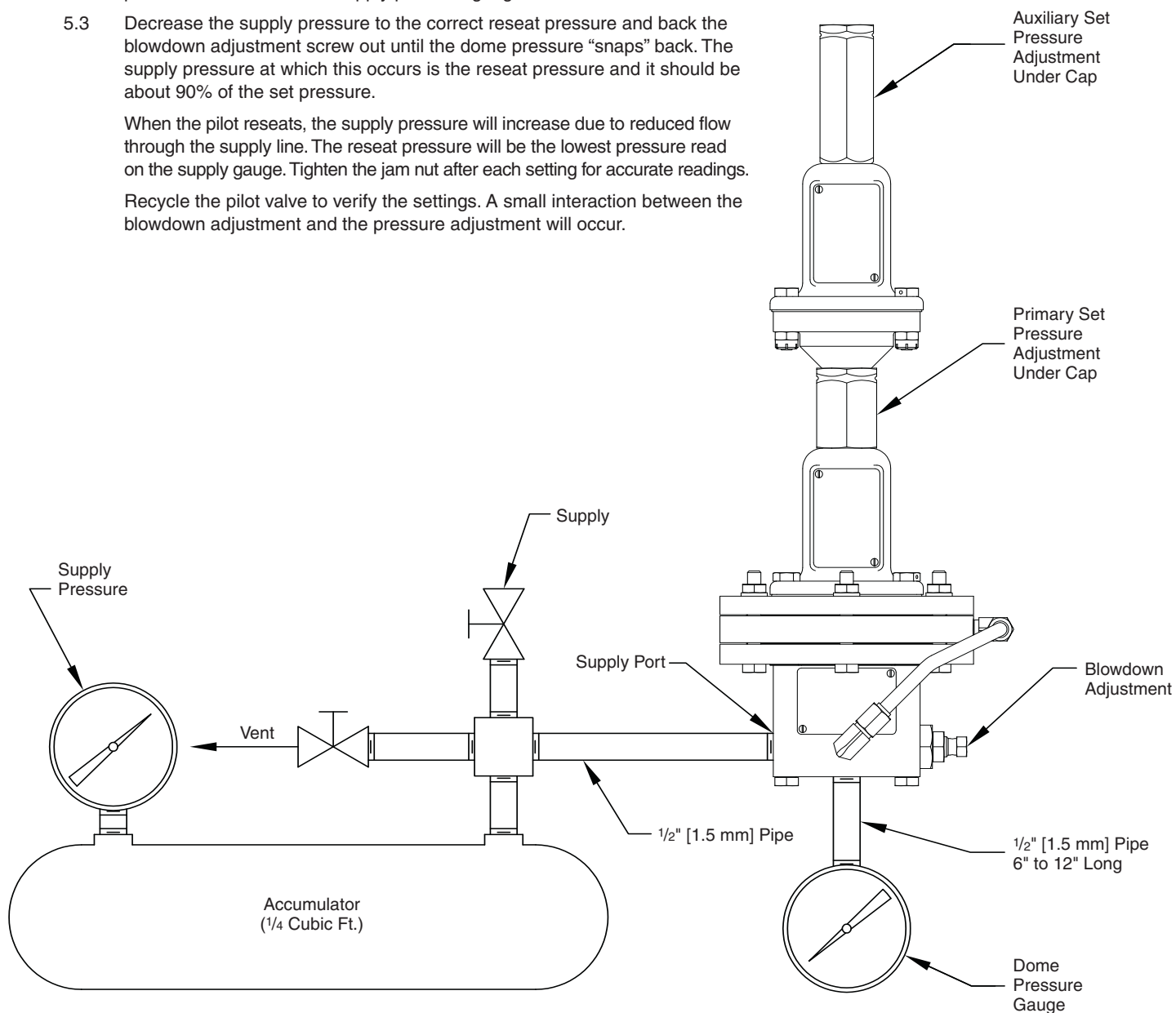

Type 95 Pilot Test Set-Up

Figure 5

Pilot Operated Safety Relief Valves (POSRV)

6.0 Pilot Set Pressure Field Test Procedure (Refer to Figure 6)

This procedure is for measuring the pressure where the valve will open. It will not measure where the valve closes. To measure the closing pressure, use the procedure in Section 5.0.

- 6.1 Remove the pilot discharge tube from the pilot and replace with a cap that has a .06" diameter [1.5 mm] hole in it.
- 6.2 Connect the test equipment to the field test valve.
- 6.3 With the metering and vent valve closed, open the gas bottle and adjust the regulator pressure to about 200 psi [14 kp/cm²].
- 6.4 Open the field test valve. Slowly open the metering valve and observe the test gauge. Increase the pressure until gas flow at the pilot discharge fitting increases rapidly. The pressure at which this occurs is the set pressure of the valve.
- 6.5 To adjust the opening pressure turn the spring adjusting screw under the cap/adaptor "in" to increase pressure or "out" to decrease pressure.
- 6.6 The IMO (International Maritime Organization) Rule set pressure tolerances are:

+ 10%	0 - 21.3 psi [0 - 1.5 kp/cm ²]
+ 6%	21.3 - 42.7 psi [1.5 - 3.0 kp/cm ²]
+ 3%	42.7 psi or 3.0 kp/cm ² and above

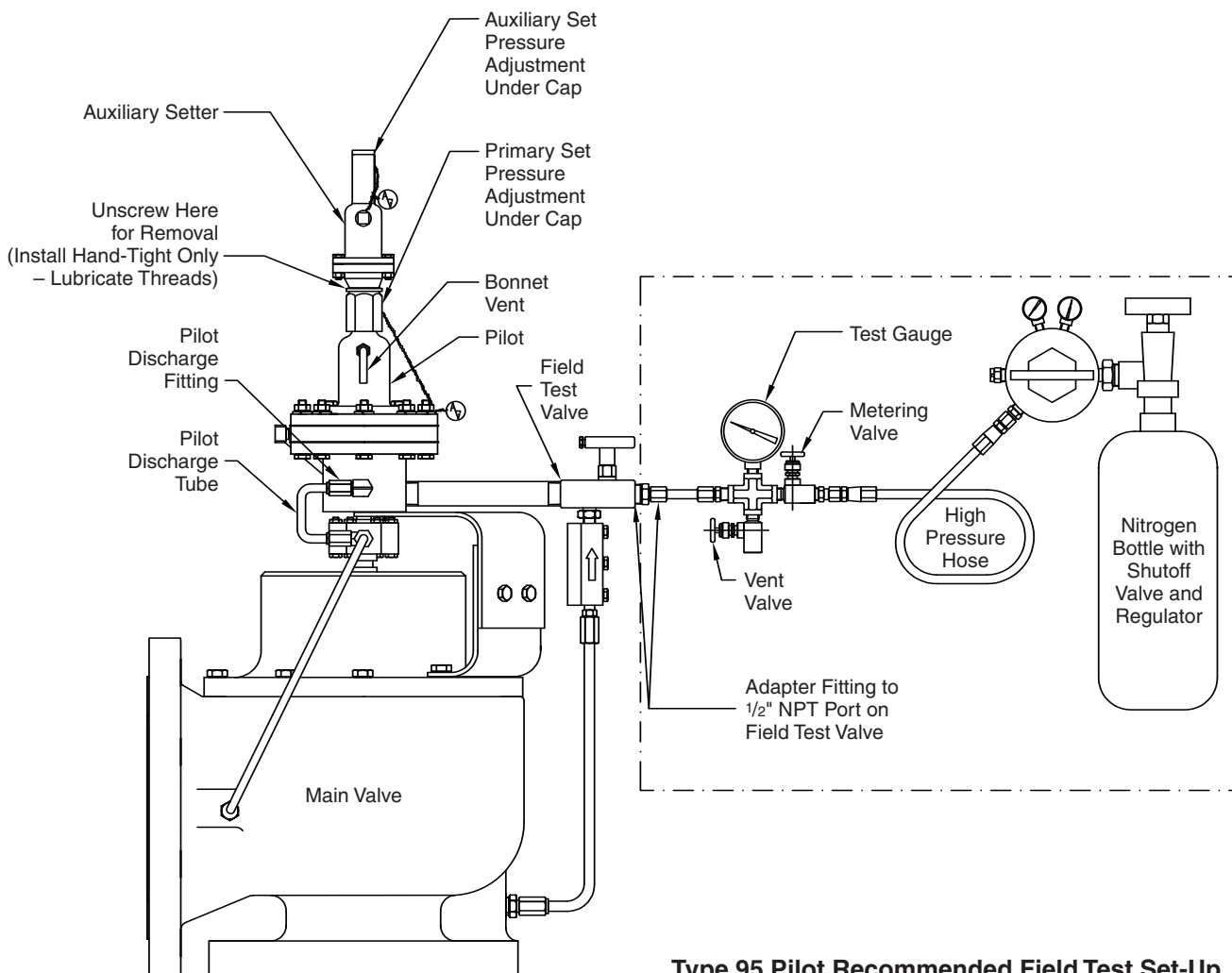

Type 95 Pilot Recommended Field Test Set-Up

Figure 6

Pilot Operated Safety Relief Valves (POPRV)

7.0 Valve Diagnosis Guide

Problem	Causes
Valve does not close on start-up with little or no cargo tank pressure	(Refer to Figure 1) Main valve piston in lift position, Pressurize dome through Field Test Handvalve [0.5 to 1.0 kp/cm ²] to close piston.
Valve opens at a pressure below nameplate set pressure	Set pressure Incorrect Auxiliary setter device incorrect one for valve. Auxiliary setter device not screwed down all the way, Pilot sense diaphragm leaks. Check for gas flow through pilot spring bonnet vent. Backflow preventer check valve leaks. (Item 15, Figure 2) Check for gas flow at discharge tube to main valve outlet. No gas flow Should be detected.
Valve opens at correct pressure but does not close	Pilot not sensing correct tank pressure Check valve in tank pressure sense line (Figure 1) restricted. Filter screen in pilot or small orifices in pilot restricted. IMPORTANT IN AN EMERGENCY, MAIN VALVE CAN BE CLOSED BY PRESSURIZING DOME (TOP OF PISTON) THROUGH CLOSE TEE (ITEM 13, FIGURE 2) REMOVE PLUG (ITEM 18) AND APPLY PRESSURE EQUAL TO TANK PRESSURE.

8.0 Repair Kits

Main Valve Size	Soft Goods Kit Part Number	Bolt Kit Part Number
2 x 3	04.4744.810	04.4744.330
3 x 4	04.4744.804	04.4744.331
4 x 6	04.4744.834	04.4744.332
6 x 8	04.4744.835	04.4744.333
Pilot	04.4744.025	04.4744.333
Backflow Preventer (Diaphragm)	04.4744.781	04.4744.335
Check Valve (Ball Check)	04.4744.782	None

Stafford Facility Phone: 281-274-4400

www.tycoflowcontrol.com

Tyco Flow Control (TFC) provides the information herein in good faith but makes no representation as to its comprehensiveness or accuracy. This IOM is intended only as a guide to TFC products and services. Individuals using this IOM must exercise their independent judgment in evaluating product selection and determining product appropriateness for their particular purpose and system requirements. TFC MAKES NO REPRESENTATIONS OR WARRANTIES, EITHER EXPRESS OR IMPLIED, INCLUDING WITHOUT LIMITATION ANY WARRANTIES OF MERCHANTABILITY OR FITNESS FOR A PARTICULAR PURPOSE WITH RESPECT TO THE INFORMATION SET FORTH HEREIN OR THE PRODUCT(S) TO WHICH THE INFORMATION REFERS. ACCORDINGLY, TFC WILL NOT BE RESPONSIBLE FOR DAMAGES (OF ANY KIND OR NATURE, INCLUDING INCIDENTAL, INDIRECT, OR CONSEQUENTIAL DAMAGES) RESULTING FROM THE USE OF OR RELIANCE UPON THIS INFORMATION. Patents and Patents Pending in the U.S. and foreign countries. Tyco reserves the right to change product designs and specifications without notice.

Engineering Doc. #05.9040.083 Rev. E