

Pilot Operated Safety Relief Valves (POSRV)

ANDERSON GREENWOOD

Before installation these instructions must be fully read and understood.

The intent of these instructions is to acquaint the user with the storage, installation and operation of this product. **Please read these instructions carefully before installation.**

Safety Precautions

When the pressure relief valve is under pressure never place any part of your body near the pilot exhaust nor the outlet of the main valve.

The main valve outlet should be piped or vented to a safe location.

Always wear proper safety gear to protect head, eyes, ears, etc. anytime you are near pressurized valves.

Never attempt to remove the pressure relief valve from a system that is pressurized.

Never make adjustments to or perform maintenance on the pressure relief valve while in service unless the valve is isolated from the system pressure. If not properly isolated from the system pressure, the pressure relief valve may inadvertently open resulting in serious injury.

Remove the pressure relief valve prior to performing any pressure testing of the system.

The safety of lives and property often depends on the proper operation of the pressure relief valve. The valve must be maintained according to appropriate instructions and must be periodically tested and reconditioned to ensure correct function.

Warning

Removal of the seal wires in an attempt to adjust and/or repair this product by unauthorized or unqualified persons voids the product warranty and may cause damage to equipment and serious injury or death to persons.

The product is a safety related component intended for use in critical applications. The improper application, installation or maintenance of the product or the use of parts or components not manufactured by Anderson Greenwood may result in a failure of the product.

Any installation, maintenance, adjustment, test, etc. performed on the Product must be done in accordance with the requirements of all applicable Anderson Greenwood Procedures and Instructions as well as applicable National and International Codes and Standards.

Storage and Handling

Pressure relief valve performance may be adversely affected if the valve is stored for an extended period without proper protection. Rough handling and dirt may damage, deform, or cause misalignment of valve parts and may alter the pressure setting and adversely affect valve performance and seat tightness. It is recommended that the valve be stored in the original shipping container in a warehouse or as a minimum on a dry surface with a protective covering until installation. Inlet and outlet protectors should remain in place until the valve is ready to be installed in the system..

Table of Contents

1.0	General Valve Description and Start-Up	2
2.0	Main Valve Maintenance	3
3.0	Pilot Maintenance	5
4.0	Pilot Set Pressure Adjustment	9
5.0	Accessory Repair.....	12
6.0	Leak Testing Assembly	14
7.0	Pilot Set Pressure Field Test Procedure	15
8.0	Soft Goods Repair Kits	16

Pilot Operated Safety Relief Valves (POSRV)

1.0 General Valve Description and Start-up

1.1 Operation

The Anderson Greenwood Pilot Operated Safety-Relief Valves utilize the principle of back-loading the top, or large area, of a differential area bellows with line pressure to hold the bellows closed up to set pressure. At set pressure the pilot valve relieves, partially evacuating the dome (volume in the bellows) and the bellows lifts permitting discharge from the main valve. When the pilot reseats, line pressure is diverted to the dome closing the main valve.

1.2 Installation

The valve should be installed in accordance with accepted piping practices, in an upright position as shown in Figure 1.

When remote pressure pick-up is used the pilot supply tube is connected to a remote location rather than to the inlet neck of the valve. If a block valve is used in the remote pilot supply line, be sure it is opened before pressurizing the system or opening the isolating block valve under the main valve, if one is used.

NOTE: Remote pressure pick-up piping must have the equivalent flow area of 1/2" [15 mm] tubing for lengths up to 20 feet [6.1 m]. For lengths greater than 20 feet [6.1 m], larger tubing or pipe should be used.

1.3 Start-Up

There must be pressure at the valve inlet to establish a differential in force across the bellows and "load" it in the closed position. Pressure must pass through the pilot supply tube and pilot, and exert force in the bellows. On normal start-up, the valve loads itself without incident as pressure increases.

Block valves are often used under safety valves in order to isolate them when maintenance is required. When putting the safety valve in service be sure the block valve is fully opened. If the block valve is opened after system start-up, the safety valve, may briefly vent before the dome gets pressurized. It will then close off positively.

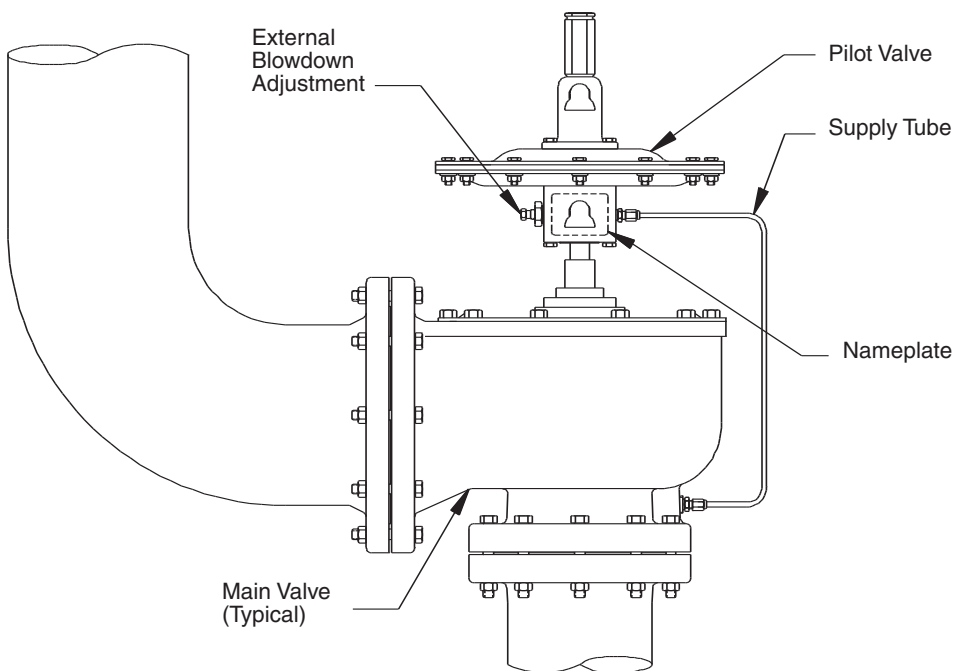

Figure 1

Pilot Operated Safety Relief Valves (POSRV)

2.0 Main Valve Maintenance (Refer to Figure 2)

2.1 Disassembly

Remove hex bushing from guide tower, then remove cap from body by lifting cap vertically until guide tower disengages the guide tube on the bellows. Turn cap assembly upside down to remove drag ring assembly on those valves where it is used. It is not necessary to remove guide tower from cap unless one of these parts is to be replaced.

Lift bellows assembly with seat from body. Remove guide bolt to separate guide and seat plate from bellows. The bellows shield, where used, can now be removed. Remove seat retainer from seat plate and Teflon seats.

2.2 Repair

Clean all metal parts, and replace seat and seals, as required. The nozzle may be removed from the body if it cannot be adequately cleaned.

Install a new film seat by placing the film over the seat plate with the edges of the film extending beyond the outside diameter of the plate. Place the secondary seat on the film and the retainer over the secondary seat. Align the holes in the retainer with those in the seat plate and press the retainer down evenly over the seat plate ridge. Larger size valves may require that the retainer be pulled into place with the retainer screws. Start several screws in opposite holes using the screws to pierce through holes in the film and tighten one screw at a time.

NOTE: The film must be stretched tight and be free of wrinkles and scratches to insure a bubble-tight seal. Install the remaining screws in the seat retainer, trim the excess film from the outer diameter and cut a hole in center for the guide bolt.

2.3 Assembly

Assemble in reverse order of disassembly. If the nozzle was removed from the body, cross torque socket head nozzle cap screws to 45/55 in.lbs. [5.1/6.2 N·m].

The bellows shield must be installed on the bellows before the seat plate assembly is attached. A seal is used under the head of the guide bolt and between the seat plate and guide tube. On 6" [150 mm] and larger valves, a lockwasher is used under the locknut. Place the bellows assembly in the valve body. The top of the bellows and bellows shield, where used, must locate in the counterbore of the body. Locate the cap gasket on the bellows top plate and place the cap with guide tower in place. The cap gasket should be positioned in the counterbore. If not, the cap may be tilted, causing the bellows and seat plate to tip and the seat to leak. Some lubricant placed on the gasket will help keep it in place. Install the cap bolts and cross torque to 55/65 ft. lbs. [6.21/7.35 N·m].

Install drag ring assembly around bellows guide in guide tower in sequence shown in Figure 2. The wedge and taper rings **must be fully seated** in the bottom of the tower. When properly assembled, these rings will be below the top of the bellows guide. Install the spring and spacer in the tower. Apply a light coat of lubricant to the hex bushing and install in the guide tower. It will be necessary to compress the spring to install the bushing.

Refer to Page 16 for Soft Goods Repair Kits.

Anderson Greenwood Type 91 and 94 POSRV

Maintenance Instructions

Pilot Operated Safety Relief Valves (POSRV)

Item	Description
100	Body
110	Screw
140	Retainer Seat
150	Retainer Seat Disc
160	Plate – Seat
170	Bellows
180	Bellows Shield (1)
210	Cap
310	Flange – Guide Tower
320	Guide – Bellows
340	Guide – Tower
350	Ring – Taper (2)
360	Ring – Wedge (2)
370	Ring – Spacer (2)
380	Spring (2)
400	Dipper Tube
410	Plug – Pipe (not shown)
420	Guide Bolt
460	Nozzle
490	Bolt

Item	Description
500	Bushing – Hex
510	Nut
520	Nut
540	Screw
550	Washer
* 560	Guide Tower Seal
* 570	Secondary Seat
* 590	Bellows Guide Seal
* 610	Primary Seat
* 620	Cap Gasket
* 630	Nozzle Gasket
* 640	Guide Bolt Seal
650	Bolt Seal
700	Cap Bolt – Hex
710	Cap Bolt – Eye (3)
750	Tubing
760	Nipple

* Recommended spare parts for repairs

(1) used > 15 psig, except in 2" x 3"

(2) used ≥ 6" valve and >1 psig

(3) not shown – used on ≥ 4"

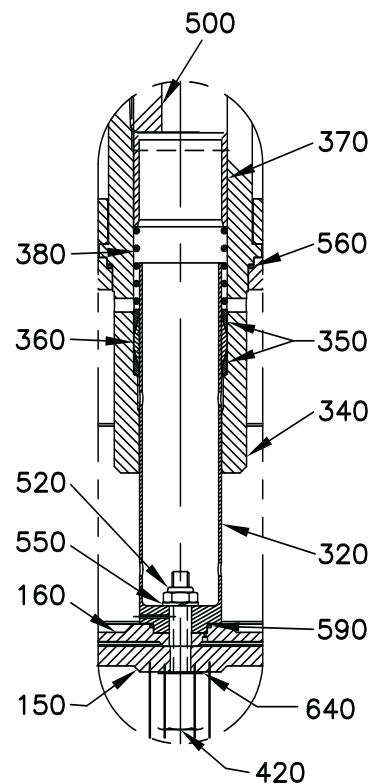

Drag Ring Assembly
(Used in ≤ 6" [150 mm])

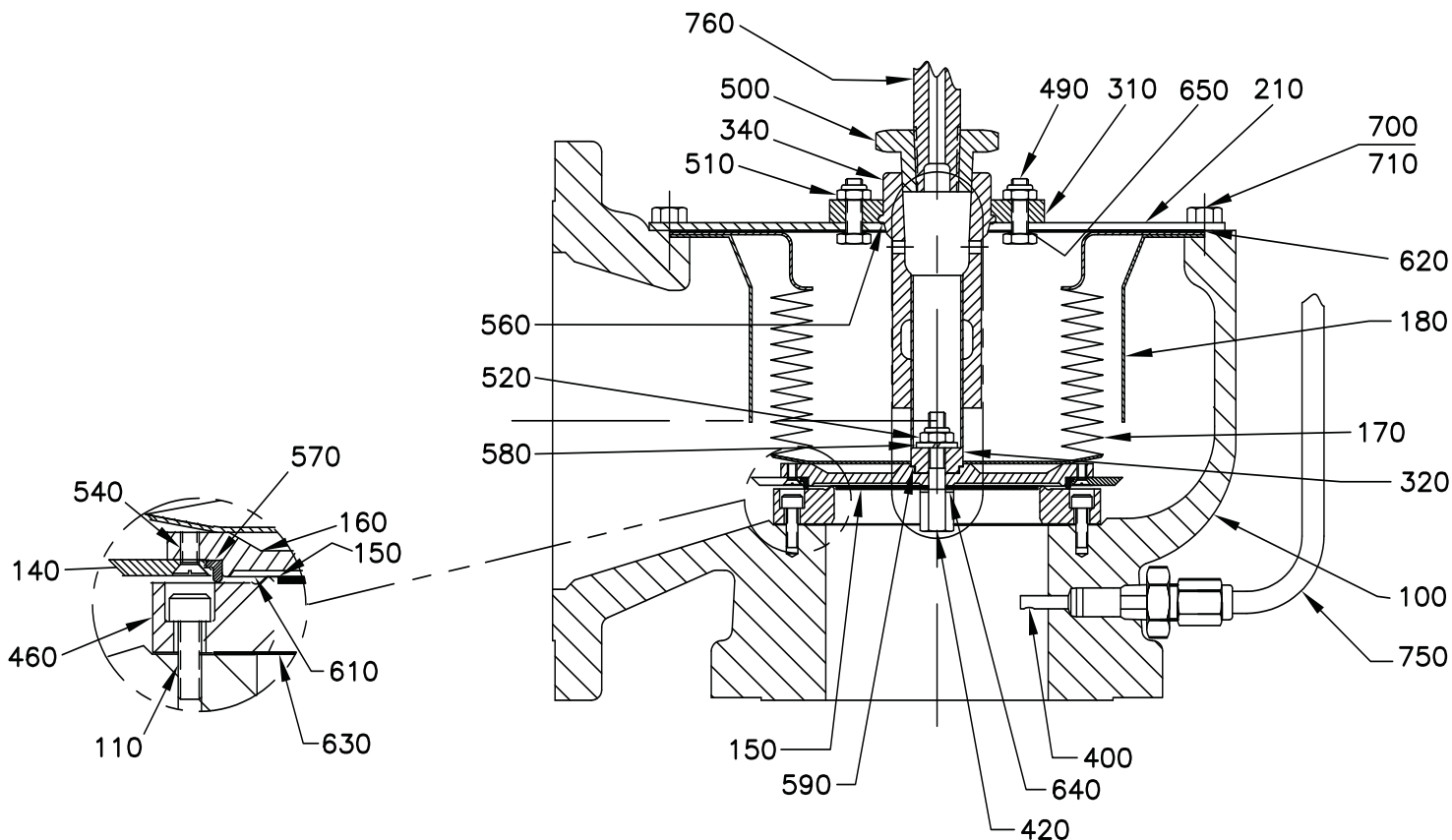

Figure 2

Engineering Doc. #05.9040.080 Rev. J

Pilot Operated Safety Relief Valves (POSRV)

3.0 Pilot Maintenance (Figures 3, 4, and 5)

3.1 Disassembly

To facilitate assembly, place all parts removed in an orderly arrangement so the correct parts are assembled in the proper sequence. Refer to the appropriate figure for parts description and location.

- 3.1.1 Begin by removing spring bonnet (Remove the spring compression before attempting to remove bonnet). Remove case bolts and upper case. Loosen tube fittings on boost tube at lower case and body. Remove spindle nut while holding hex spacer. Remove diaphragms, sense & boost plates and spacers. Remove lower case and spindle/seat assembly. Remove blowdown adjustment screw and supply port tube fitting.
- 3.1.2 Clean all parts and replace all soft goods. The spindle/seat assembly in the Type 94 pilot is factory assembled and must be replaced as a unit. If the nozzle in this pilot is nicked or scratched, it should be replaced. To remove it, use a deep socket.

The nozzles used on plastic seated pilots can be reworked, if scratched, by lapping flat a 2 microinch [0.05 micrometer] finish.

3.2 Assembly

Assembly is done in the reverse order of disassembly. Lubricate all screw threads and end of spring adjusting screw that bears against spring washer. Use Dow Corning No. 33 Silicone grease or equivalent. When assembling pilot, the following should be observed:

- 3.2.1 The holes in spindle diaphragm must be aligned with all holes in the body. The small hole in lower case must be aligned with hole in the body. Two of the six case bolts for the medium pressure pilot (Figures 4 or 5) must be assembled through holes in the lower case before it is attached to the body. After attachment there is insufficient clearance to do so.
- 3.2.2 For the medium pressure Type 94 pilot (Figure 5), the hole in the boost (lower) diaphragm and spacer ring must be aligned with boost tube port in lower case. The hole in the upper diaphragm must be positioned away from boost tube part.
- 3.2.3 Before tightening spindle nut, align holes in lower case, spacer ring and diaphragms with case bolts.

Tighten spindle nut snugly but not excessively. Three diaphragms are sandwiched in the spindle/stack assembly and excessive tightening will damage them. Hold the hex spacer when torquing spindle nut to prevent the stack from rotating.
- 3.2.4 Type 91 pilots used on valves for Marine service have a Teflon sense diaphragm. Standard Type 91 pilots use a stainless steel sense diaphragm.

Both Type 91 and Type 94 pilots use gaskets on the sense and boost diaphragms. The Type 91 pilot also has gaskets on the spindle diaphragm.

Refer to Page 16 for Soft Goods Repair Kits.

Anderson Greenwood Type 91 and 94 POSRV

Maintenance Instructions

Pilot Operated Safety Relief Valves (POSRV)

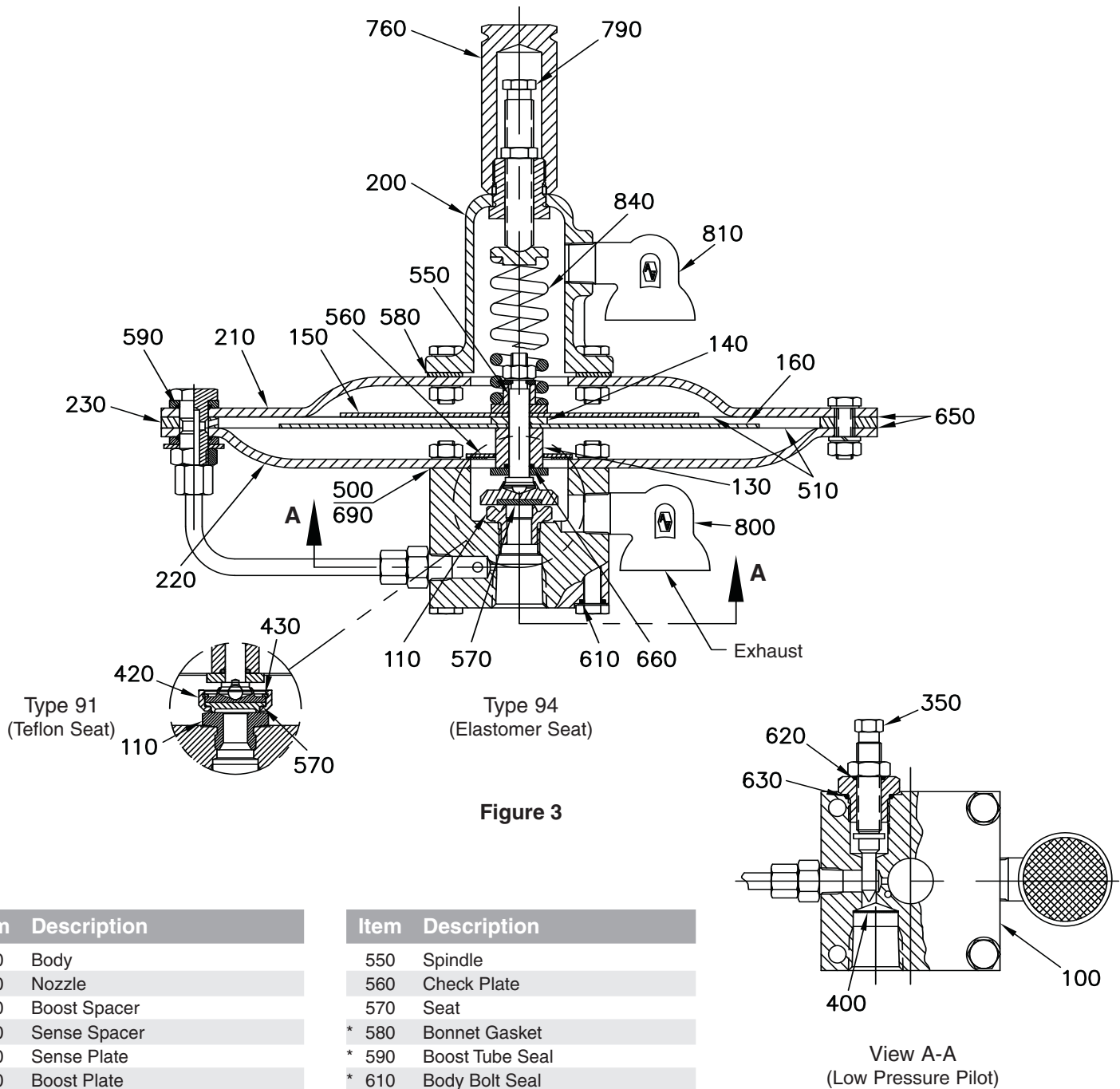
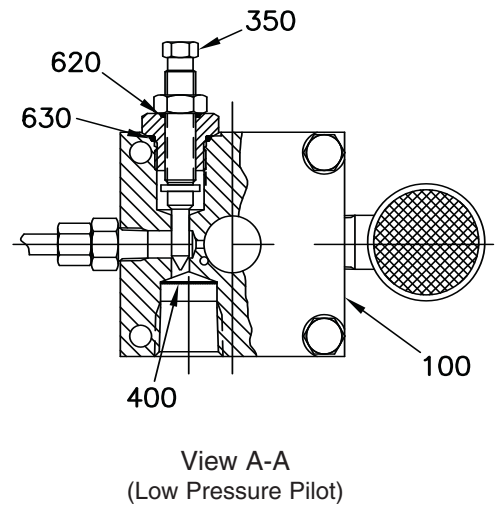

Figure 3

Item	Description
100	Body
110	Nozzle
130	Boost Spacer
140	Sense Spacer
150	Sense Plate
160	Boost Plate
200	Bonnet Assembly
210	Upper Diaphragm Case
220	Lower Diaphragm Case
230	Spacer Ring
350	Blowdown Adjustment Needle
400	Filter Screen
420	Seat – Retainer (Type 94 only)
430	Ring – Retainer (Type 94 only)
500	Diaphragm Needle
510	Diaphragm – Sense/Boost

Item	Description
550	Spindle
560	Check Plate
570	Seat
* 580	Bonnet Gasket
* 590	Boost Tube Seal
* 610	Body Bolt Seal
* 620	Blowdown Seal
* 630	Bushing Seal
* 650	Diaphragm Gasket
* 660	Spindle Seal
* 690	Spindle Diaphragm Gasket ⁽¹⁾
760	Cap
790	Pressure Adjustment Screw
800	Body Vent
810	Bonnet Vent
830	Disc – Spring

* Recommended spare parts for repairs
⁽¹⁾ only used if item 500 is Teflon®



Pilot Operated Safety Relief Valves (POSRV)

Item	Description
100	Body
110	Nozzle
130	Boost Spacer
140	Sense Spacer
150	Sense Plate
160	Boost Plate
200	Bonnet Assembly
210	Upper Diaphragm Case
220	Lower Diaphragm Case
230	Spacer Ring
350	Blowdown Adjustment Needle
400	Filter Screen
420	Seat – Retainer
430	Ring – Retainer
500	Spindle Diaphragm
510	Diaphragm – Sense
550	Spindle
560	Check Plate
570	Seat
* 580	Bonnet Gasket
* 590	Boost Tube Seal
* 610	Body Bolt Seal
* 620	Blowdown Seal
* 630	Bushing Seal
* 640	Gasket Case
* 660	Spindle Seal
* 690	Spindle Diaphragm Gasket ⁽¹⁾
760	Cap
790	Pressure Adjustment Screw
800	Body Vent
810	Bonnet Vent
840	Spring

* Recommended spare parts for repairs
⁽¹⁾ only used if item 500 is Teflon®

Type 91

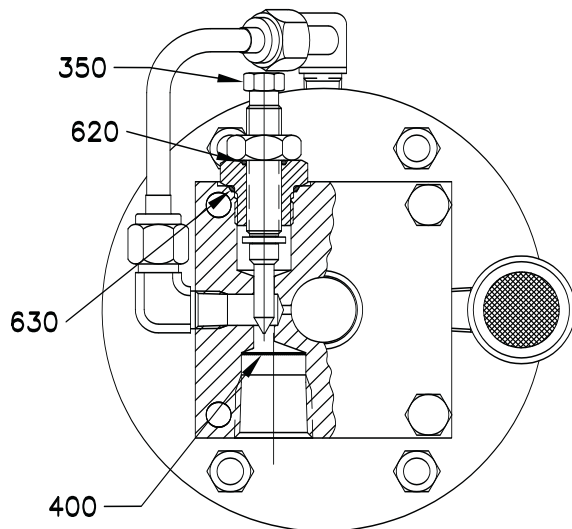
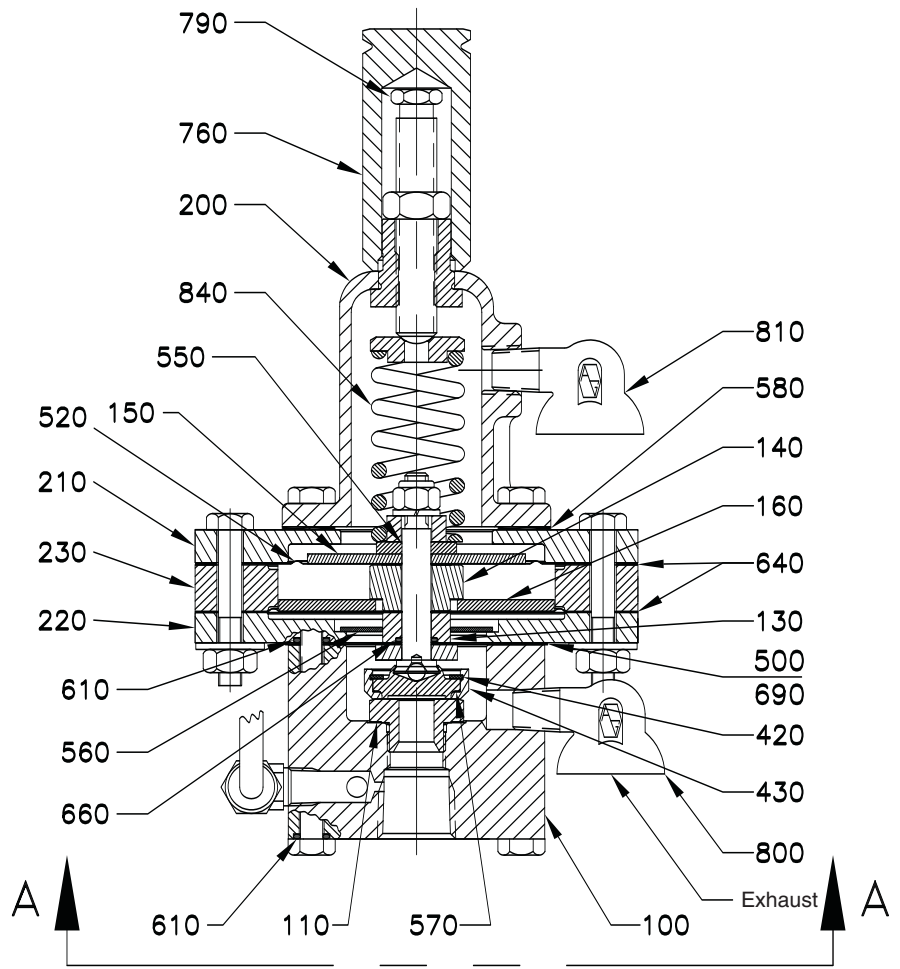

View A-A

Figure 4

Pilot Operated Safety Relief Valves (POSRV)

Type 94

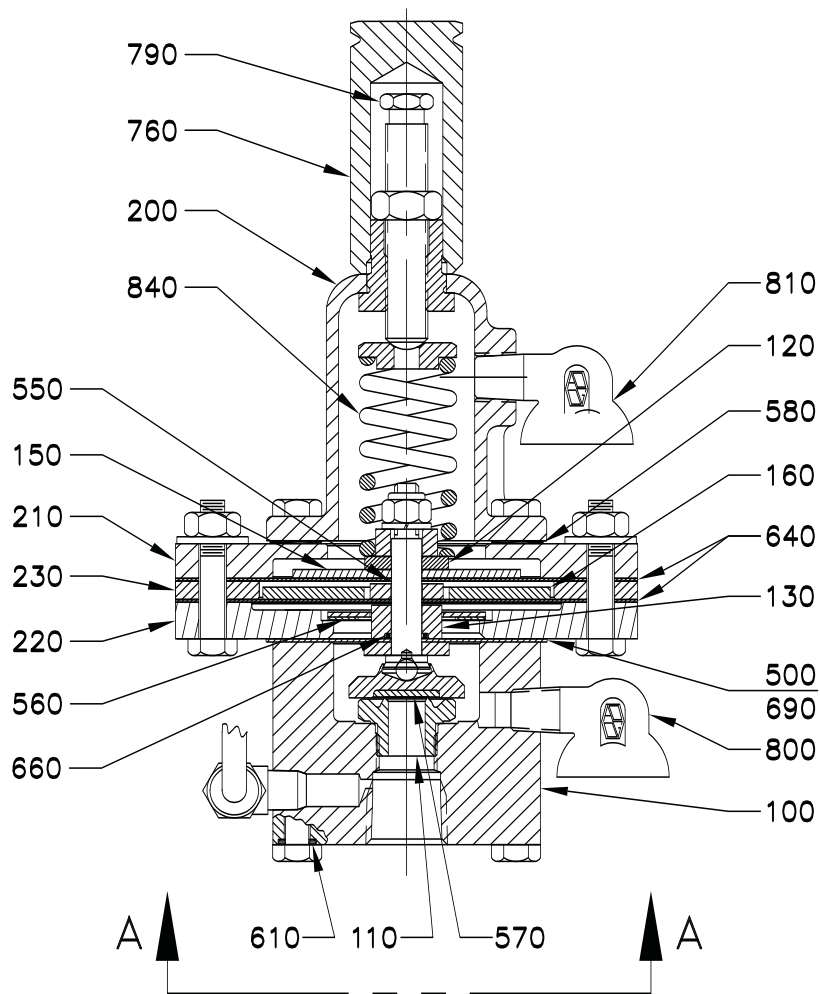

Item	Description
100	Body
110	Nozzle
120	Hex Spacer
130	Boost Spacer
150	Sense Plate
160	Boost Plate
200	Bonnet Assembly
210	Upper Diaphragm Case
220	Lower Diaphragm Case
230	Spacer Ring
350	Blowdown Adjustment Needle
400	Filter Screen
500	Spindle Diaphragm
550	Spindle
560	Check Plate
570	Seat
* 580	Bonnet Gasket
* 610	Body Bolt Seal
* 620	Blowdown Seal
* 630	Bushing Seal
* 640	Gasket Case
* 660	Spindle Seal
* 690	Spindle Diaphragm Gasket (1)
760	Cap
790	Pressure Adjustment Screw
800	Body Vent
810	Bonnet Vent
840	Spring

* Recommended spare parts for repairs
 (*) only used if item 500 is Teflon®

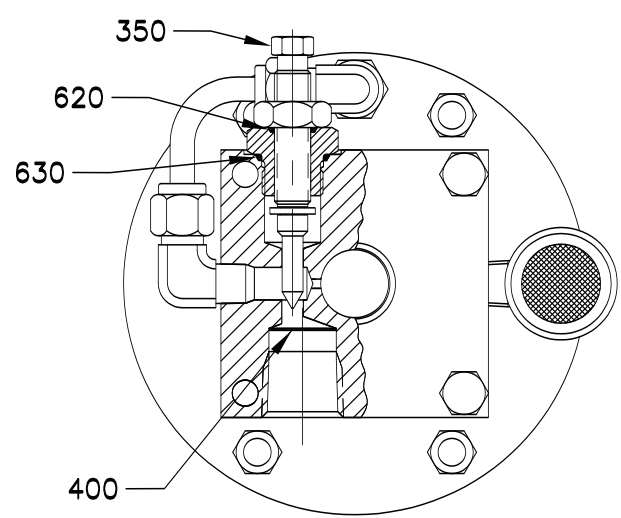

View A-A

Figure 5

Pilot Operated Safety Relief Valves (POSRV)

4.0 Pilot Set Pressure Adjustment

4.1 Pilot Adjustment

Two adjustments are provided; one for varying the pressure at which the pilot opens and one for varying the pressure at which the pilot closes. The first adjustment controls the "set" or "popping" pressure, the second the "reseat" or "blowdown" pressure. To adjust set pressure, a test set-up similar to that shown in Figure 6 should be used.

4.2 Set Pressure

This adjustment is obtained by turning the pressure adjusting screw, clockwise (in) to increase set pressure and counter-clock-wise (out) to decrease set pressure.

4.3 Reseat Pressure

This adjustment is obtained by turning the blowdown adjusting needle screw, clockwise (in) to increase blowdown, counter-clockwise (out) to decrease blowdown. A small interaction between set pressure and reseal pressure adjustments will occur, therefore it may be necessary to readjust the set pressure after setting reseal pressure.

NOTE: If the blowdown adjusting screw has been moved or turned to either extreme, positioning it midway will aid in obtaining the correct blowdown. There are approximately 7 to 8 turns to obtain full travel of the adjustment. Midway from either end should produce a blowdown for "snap action". For "modulating pilot action", back the adjustment screw out (counter- clockwise) to obtain the adjustment limits given in paragraph 4.5.

4.4 Range of Adjustment

All Pilots can be adjusted $\pm 10\%$ beyond the nameplate setting.

Pilot Operated Safety Relief Valves (POSRV)

4.5 Adjustment Tolerances

Non-Marine Service

Pilot Action ⁽¹⁾	Set Pressure		Set Pressure Tolerance	Minimum Crack Pressure as % of Set	Supply Pressure as % of Set for Dome Pressure Recovery ⁽²⁾
	English (psig)	Metric (kpag)			
Snap	7" WC to 1.0 psig	1.74 kpag to 6.89 kpag	± 3%	90	90 ± 1
	Above 1 psig to 15 psig	Above 6.89 kpag to 103 kpag	± 3%	92 ¹ / ₂	92 ¹ / ₂ ± 1/2
Modulating	Above 15 psig to 50 psig	Above 103 kpag to 345 kpag	± 3%	92 ¹ / ₂	92 ¹ / ₂ ± 1/2
	-7" WC to -1.0 psig	-1.74 kpag to -6.89 kpag	± 3%	90	90 ± 1
Snap	Above -1.0 psig to -14.7 psig	Above -6.89 kpag to -101 kpag	± 3%	92 ¹ / ₂	90 ¹ / ₂ ± 1/2
	7" WC to 1.0 psig	1.74 kpag to 6.89 kpag	± 3%	90	100 + 0/-2
Modulating	Above 1.0 psig to 15 psig	Above 6.89 kpag to 103 kpag	± 3%	92 ¹ / ₂	100 + 0/-2
	Above 15 psig to 50 psig	Above 103 kpag to 345 kpag	± 3%	92 ¹ / ₂	100 + 0/-2
Snap	-7" WC to -1.0 psig	-1.74 kpag to -6.89 kpag	± 3%	90	100 + 0/-2
	Above -1.0 psig to -14.7 psig	Above -6.89 kpag to -101 kpag	± 3%	92 ¹ / ₂	100 + 0/-2

Marine Service

Pilot Action ⁽¹⁾	Set Pressure		Set Pressure Tolerance	Minimum Crack Pressure as % of Set	Supply Pressure as % of Set for Dome Pressure Recovery ⁽³⁾
	English (psig)	Metric (kpag)			
Snap	4 psig to 21 psig	27.6 kpag to 145 kpag	± 10%	75	92 ± 2
	Above 21 psig to 42 psig	Above 145 kpag to 290 kpag	± 6%	75	92 ± 2
	Above 42 psig to 150 psig	Above 290 kpag to 1034 kpag	+ 3%	75	92 ± 2

NOTES: (1) *Snap Action* - Dome pressure decreases rapidly with a "snap" to 15% ± 10% of set pressure at set pressure. Pilot seat should be bubble tight at dome pressure recovery.

Modulating Action - Dome pressure decreases slowly to 30% ± 5% of set pressure and recovers to 60% ± 10% of set pressure at set pressure.

(2) Pilot seat should be bubble tight at dome pressure recovery for "snap" pilot action and at 90% of set pressure for "modulating" pilot action non-marine.

(3) For marine valves, the pilot seat should be bubble tight at 75% of set pressure.

Pilot Operated Safety Relief Valves (POSRV)

4.6 Definitions

Set Pressure

is defined as that pressure where the dome pressure is 15% of the supply pressure.

Crack Pressure

is defined as the supply pressure where gas flow begins at the pilot exhaust.

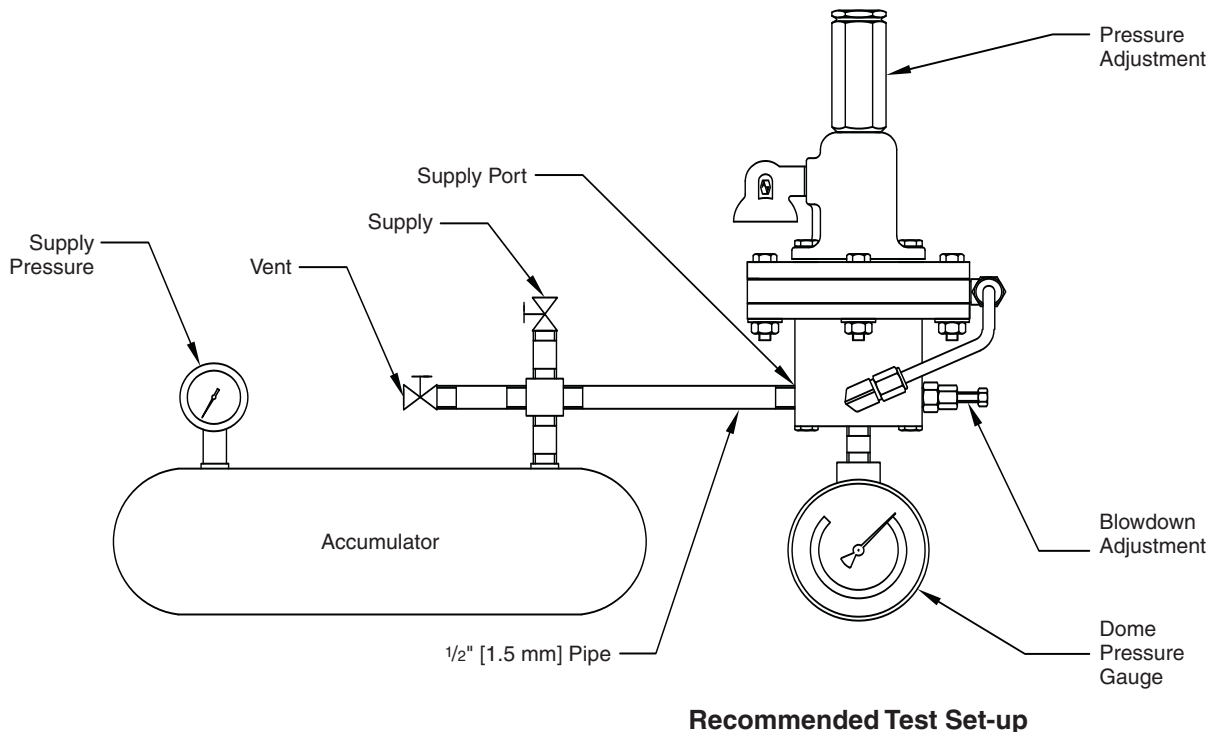
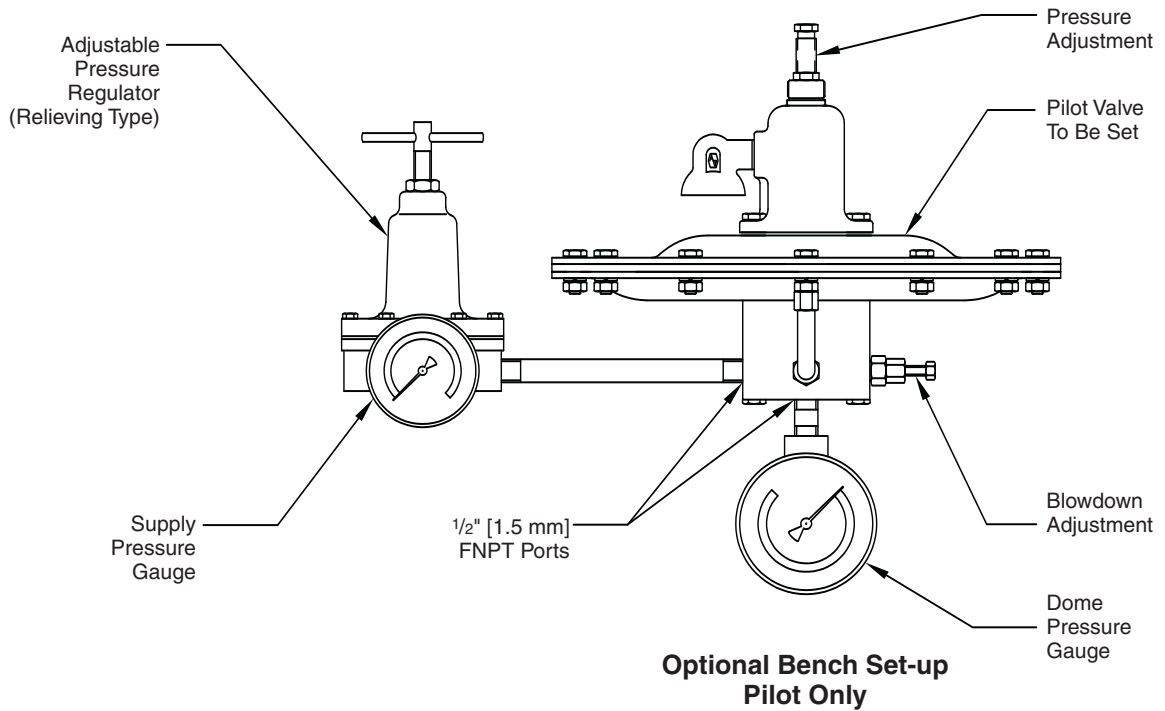

Figure 6

Pilot Operated Safety Relief Valves (POSRV)

5.0 ACCESSORY REPAIR

5.1 Check Valve

The check valves used on the Dual Pilot, Backflow Preventer, and Field Test consist of an upper body, a lower body, and a diaphragm. Refer to Figure 7.

The check valve diaphragm is the only part that should require servicing. If the diaphragm is to be replaced, care should be taken not to scratch or distort it in the center nozzle sealing area. When reassembling the check valve, uniformly tighten the body bolts, first one side, then the opposite side until all are tight. **DO NOT OVERTIGHTEN** bolts as this will distort the diaphragm and cause leakage.

Item	Description
1	Hex Head Cap Screw
2	Upper Body
3	Diaphragm
4	Nut
5	Lower Body
6	Spring Pin
7	Lockwasher
8	Diaphragm Support Washer

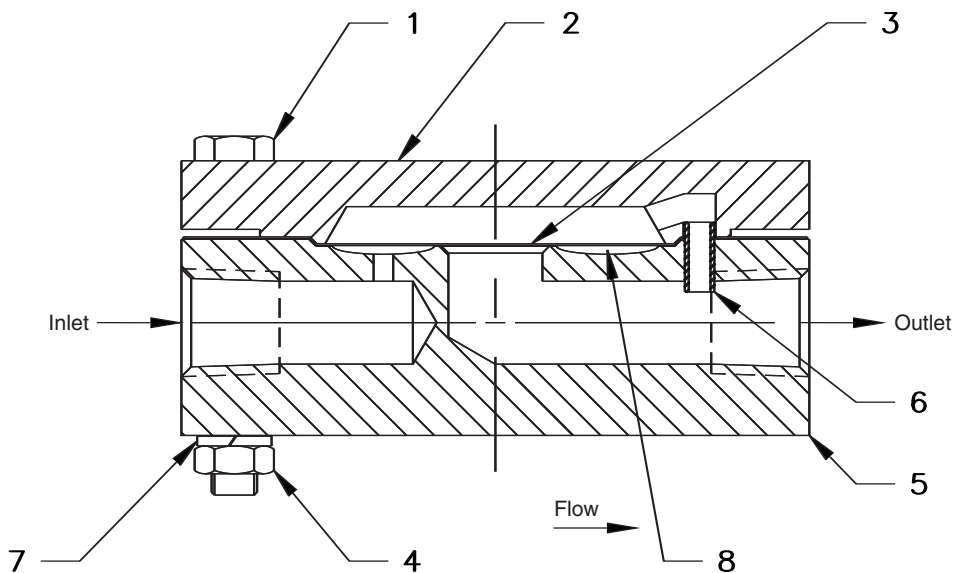

Figure 7

Pilot Operated Safety Relief Valves (POSRV)

5.2 Auxiliary Pilot Valve Setting Device

The auxiliary setting device used in those applications where multiple relief valve settings are required should require no servicing. The device is not a pressure-containing member and therefore contains no pressure seals.

Should the Extension Rod, Item 555A, Figure 8 need replacing, disassemble the device as you would a Pilot Valve Spring Bonnet and remove the Rod from the Top Washer. Install a new Rod in the Top Washer. Use Loctite "Nut Lock" adhesive or equivalent on the Rod threads before assembly to lock the two pieces together. Reassemble in the reverse order of disassembly.

To readjust the pressure setting, install the Setting Device on the Pilot Valve by threading it on the Cap Adapter until fully seated. Adjust the pressure setting as you would a Pilot Valve.

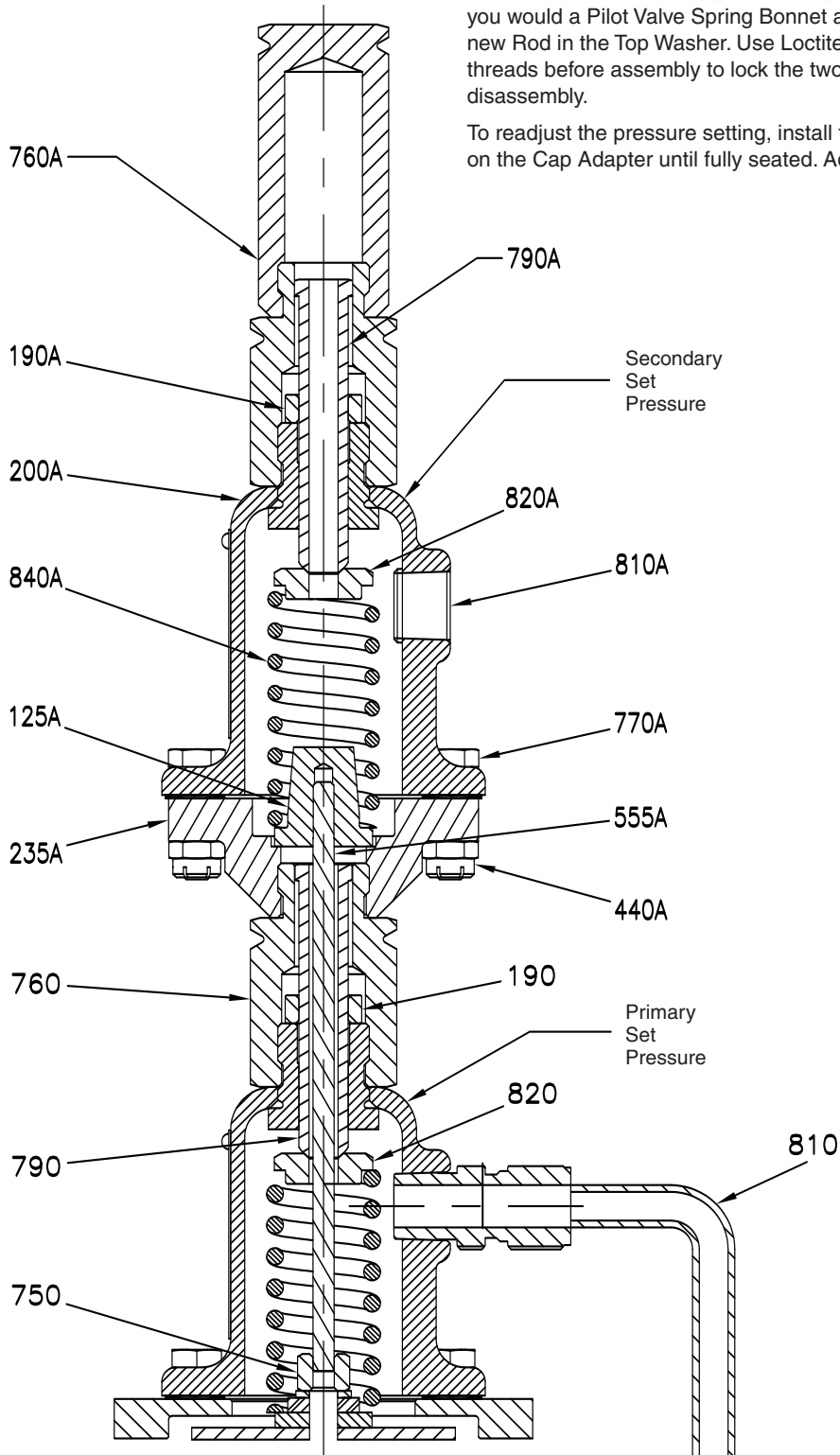

Figure 8

Item	Description
125A	Washer Top
190, 190A	Nut-Lock Pressure Adjuster
200, 200A	Bonnet Assembly
235A	Adapter
440A	Swage Nut
460, 460A	Wire
470, 470A	Seal – 1/2" Diameter
555A	Extension Rod
750	Hex Nut
760, 760A	Cap
770A	Bonnet Bolt
790, 790A	Pressure Adjustment Screw
810	Bonnet Vent
810A	Bonnet Plug
820, 820A	Spring Washer
840, 840A	Spring

A = First Auxiliary Setter

Pilot Operated Safety Relief Valves (POSRV)

6.0 Leak Testing Assembly

6.1 General

The complete valve assembly should be leak tested for internal and external leaks using a pressure equal to 10% and 90% of set.

6.2 Internal Leak Test

Nozzle: Use a piece of wide masking tape to cover the lower part of the main valve outlet, taped across the opening 2" to 3" [50 to 76 mm] high. Pour in enough water to cover just the base of the nozzle. If bubbles are detected, the nozzle seal is leaking.

Main Seat: Pour in enough water to just cover the bottom of the bellows and seat plate. If bubbles are detected, the main seat is leaking. Nozzle or seat may be damaged or the bellows may not be seating squarely on the nozzle. Improper bellows seating may be due to incorrect assembly of cap to body. Refer to Section 2.0.

6.3 External Leak Test

Following the internal leak test, check for external leakage by applying leak test solution to all joints and seals. Tighten bolts or fittings as required.

Pilot Operated Safety Relief Valves (POSRV)

7.0 Pilot Set Pressure Field Test Procedure

7.1 General

The pilot set pressure can be checked in the field by applying an external test pressure to the pilot through the Field Test Hand Valve as shown in Figure 9.

NOTE: If the process pressure at the time of test is less than approximately 30% of the pilot set pressure, the main valve will not open. If the process pressure is greater than 30% and the main valve must remain closed, temporarily replace the pilot exhaust vent with an orifice plug having an orifice diameter of .040"/.060" [1.02 mm/1.52 mm]. This orifice must be removed on completion of Field Testing as it prevents the Main Valve from opening.

7.2 Procedure

1. Connect test gas bottle as shown in Figure 9.
2. Close vent valve "C".
3. Open Field Test Valve "B". Test gauge will read process pressure.
4. Open Block Valve "A" SLOWLY to increase pressure until pilot "pops". The set pressure will be the pressure indicated on the test gauge at the time of pop.
5. To remove test set up, close valves "A" and "B", open valve "C".

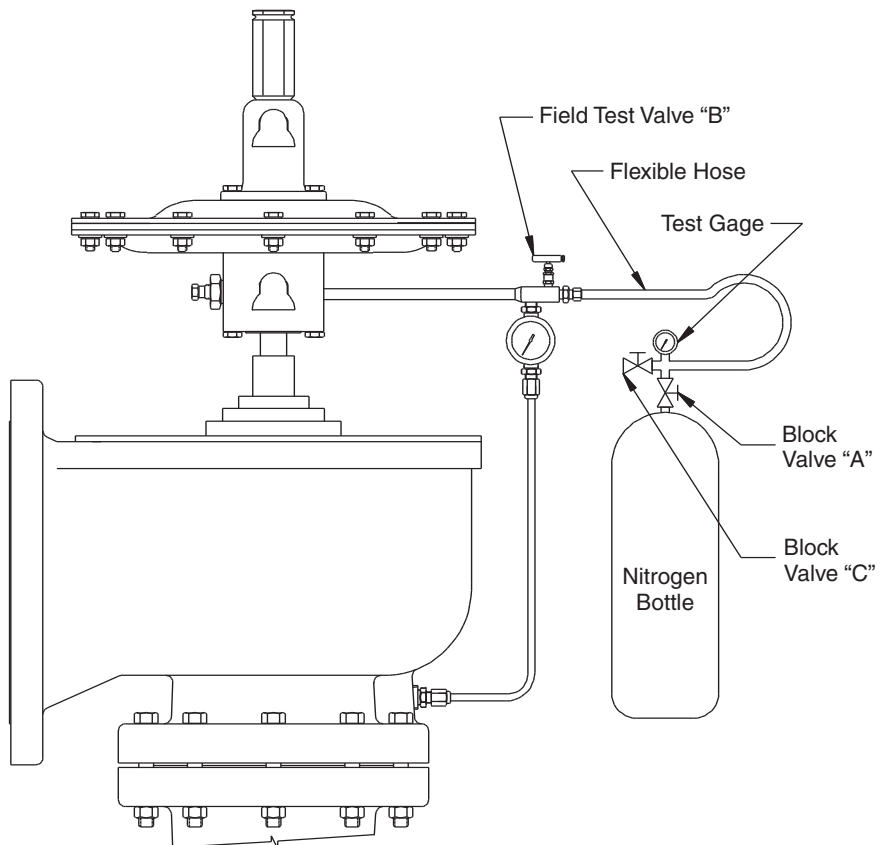

Figure 9

Pilot Operated Safety Relief Valves (POSRV)

8.0 Repair Kits

8.0 Repair Kits

Soft goods repair kits contain all the seals and seats to repair a valve. To order a kit, specify the base number and select the last three digits from the following tables. To ensure the purchase of the correct repair kit, the order should specify the valve model and serial number. For marine service the bolts in the main valve and pilot exposed to the environment should be replaced during routine maintenance or at least every five years.

Kit Base Number: 04-4744-XXX

Main Valve

Kit Type	Material	2x3	3x4	4x6	6x8	8x10	10x12	12x16
Soft Goods	Teflon®	-120	-121	-122	-123	-124	-125	-126
Bolt	SST	-337	-338	-339	-340	-341	-341	-341

Type 91 Pilot

(Complete kit consists of diaphragm plus soft goods)

Kit Type	Material	Low Pressure Below 15 psig (103 kpag)		Medium Pressure
		Vacuum	Pressure	
Soft	91 Marine	-001 ⁽³⁾	-002 ⁽³⁾	-003 ⁽⁴⁾
Goods	91 Standard	-004	-005	-003 ⁽⁴⁾
Bolt	Marine	-336	-336	-334

(3) Teflon® Sense Diaphragm. SST Boost and Spindle Diaphragms.

(4) Hastelloy® Sense, Teflon Boost, and SST Spindle Diaphragm.

Type 94 Pilot

(Complete kit consists of diaphragm plus soft goods)

Kit Type	Material	Low Pressure Below 15 psig (103 kpag)		Medium Pressure
		Vacuum	Pressure	
Soft Goods	BUNA-N	-010	-011	-012
	Viton®	-013	-014	-015
	EPR	-016	-017	-018
	BUNA-N ⁽⁶⁾	-019	-020	-896
	Viton® ⁽⁶⁾	-021	-022	-897
	EPR ⁽⁶⁾	-023	-024	-898
Bolt	SST	-342	-342	-343

(6) Teflon® Diaphragms.

Backflow Preventer Check Valve

Kit Type	Type	Material	All Pressures
Soft Goods	Diaphragm	Teflon®	-781
	Ball	BUNA-N	-344
		Viton®	-345
		EPR	-346
		Kalrez	-782
Bolt	Diaphragm	SST	-335

Pilot Operated Safety Relief Valves (POSRV)

Stafford Facility Phone: 281-274-4400

www.tycoflowcontrol.com

Tyco Flow Control (TFC) provides the information herein in good faith but makes no representation as to its comprehensiveness or accuracy. This IOM is intended only as a guide to TFC products and services. Individuals using this IOM must exercise their independent judgment in evaluating product selection and determining product appropriateness for their particular purpose and system requirements. TFC MAKES NO REPRESENTATIONS OR WARRANTIES, EITHER EXPRESS OR IMPLIED, INCLUDING WITHOUT LIMITATION ANY WARRANTIES OF MERCHANTABILITY OR FITNESS FOR A PARTICULAR PURPOSE WITH RESPECT TO THE INFORMATION SET FORTH HEREIN OR THE PRODUCT(S) TO WHICH THE INFORMATION REFERS. ACCORDINGLY, TFC WILL NOT BE RESPONSIBLE FOR DAMAGES (OF ANY KIND OR NATURE, INCLUDING INCIDENTAL, INDIRECT, OR CONSEQUENTIAL DAMAGES) RESULTING FROM THE USE OF OR RELIANCE UPON THIS INFORMATION. Patents and Patents Pending in the U.S. and foreign countries. Tyco reserves the right to change product designs and specifications without notice.