

## Maintenance instructions for Spring Operated Safety Relief Valves Type 81 with Plastic Seat.

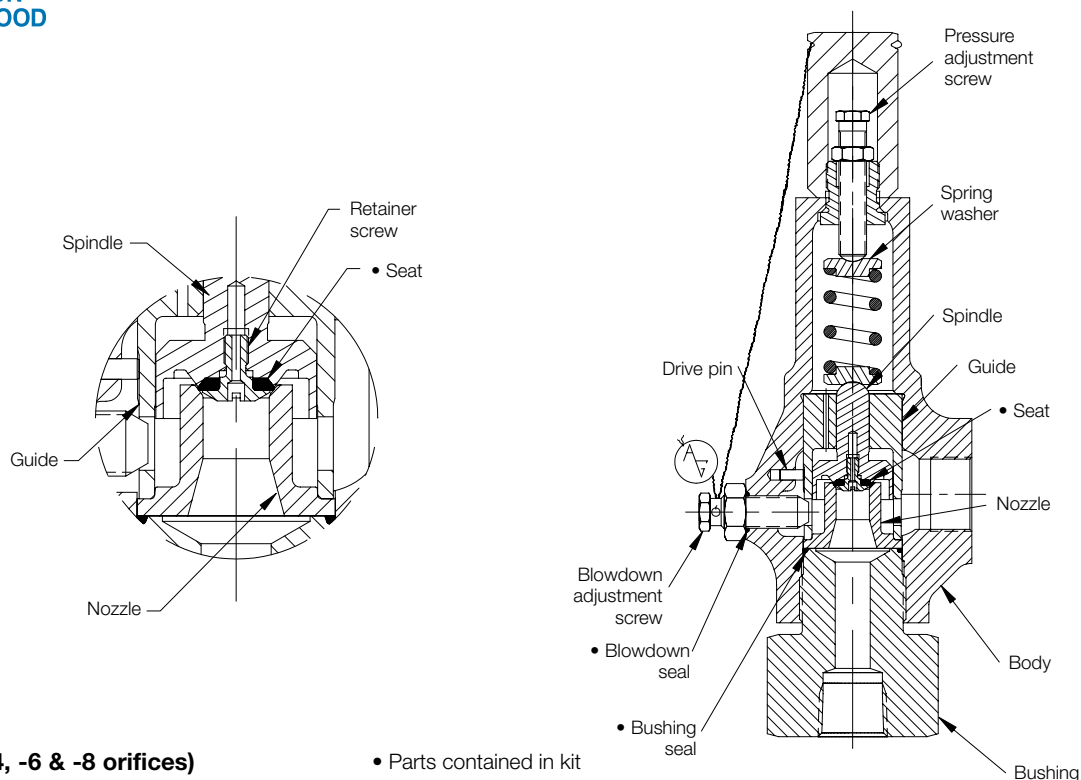

**Figure 1**  
Type 81 (-4, -6 & -8 orifices)

• Parts contained in kit

### 1. General

The Anderson Greenwood Type 81 Relief Valve is a direct acting spring loaded valve for gas service and uses a plastic seat and O-ring seals.

The intent of these instructions is to acquaint the user with the maintenance of this product. Please read these instructions carefully. This product should only be used in accordance with the applicable operating instructions and within the application specifications of the original purchase order. The installation and Operational Safety Instructions (available at [www.tycovalves.com](http://www.tycovalves.com)) should be fully read and understood before returning this product to service after maintenance.

### 2. Valve repair (-4,-6,-8 Orifice) refer to figure 1

#### 2.1 Disassembly

- 2.1.1 Relieve spring tension and back blowdown adjusting screw out two turns.
- 2.1.2 Remove inlet bushing, bushing seal and valve internals.
- 2.1.3 Separate nozzle from guide by hitting top of spindle on soft surface.

#### 2.2 Repair

- 2.2.1 Hold spindle by skirt O.D. in soft jaw vise and replace seat.
- 2.2.2 Examine nozzle and polish out any scratches or nicks. Replace if necessary.
- 2.2.3 To obtain better seat seal with Teflon at low set pressures, burnish seat against nozzle by chucking spindle in lathe and holding nozzle against spindle. Burnish with small force and for short time as Teflon readily deforms.

#### 2.3 Assembly

Assemble in reverse order of disassembly. Do not lubricate spindle or guide. Make sure the nozzle is fully and evenly seated in guide. This is a press fit joint. Lubricate threads and adjusting bolt tip.

#### 2.4 Soft goods repair kit

The part numbers for soft goods repair kits are listed below. Each kit contains the seat and all seals for the pressure ranges indicated.

Orifice	TFE/KEL-F	Set pressure range		VESPEL	Set pressure range	
		Psig	Kpag		Psig	Kpag
-4	04-4805-001	20-4000	138-27579	04-4805-002	4001 & UP	27586 & UP
-6	04-4805-003	20-1500	138-10342	04-4805-004	1501 & UP	10349 & UP
-8	04-4805-005	20-1500	138-10342	04-4805-006	1501 & UP	10349 & UP

# Maintenance Instructions

## Type 81 Spring Operated Pressure Relief Valves

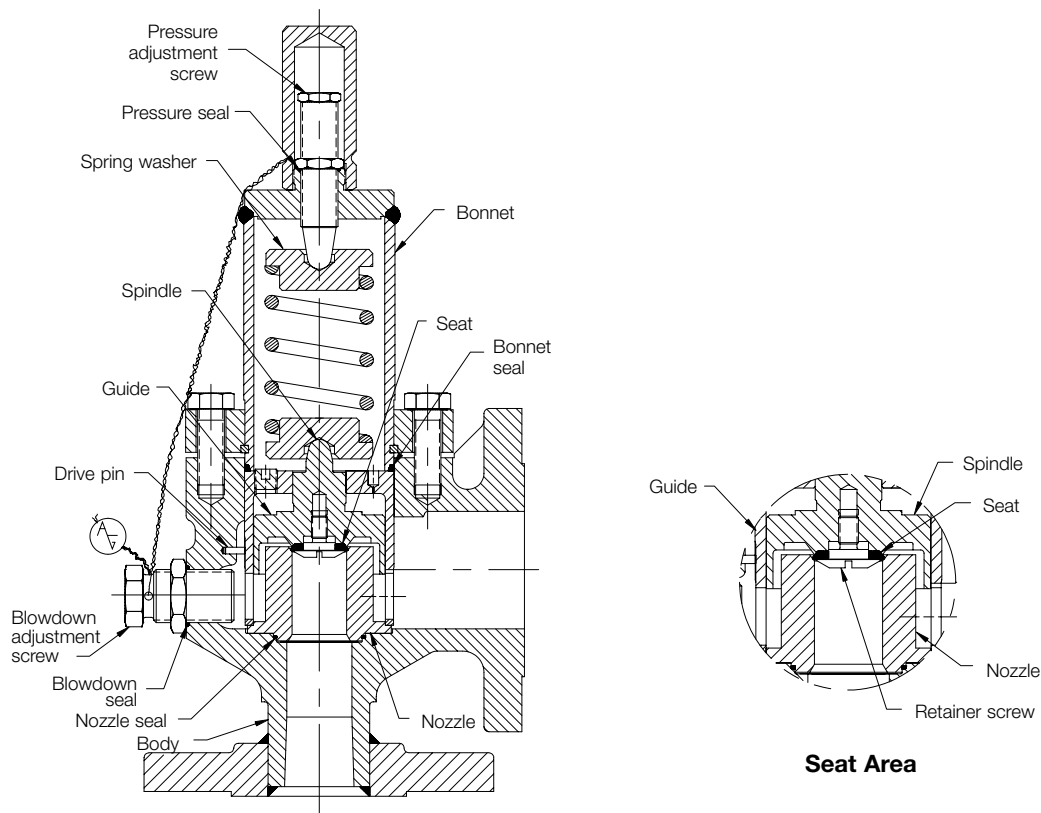

**Figure 2**  
**Type 81 (F, G, H & J orifices)**

### 3.0 Valve repair (F, G, H & J Orifice) refer to figure 2

#### 3.1 Disassembly

3.1.1 Relieve spring tension and back blowdown screw out two turns.

3.1.2 Remove spring bonnet and valve internals.

**Note:** A pipe nipple can be attached to vent holes in top of guide to facilitate removal.  
(1/8 NPT/F,G, 1/4 NPT/H,J)

3.1.3 Separate nozzle from guide by hitting top of spindle on soft surface.

#### 3.2 Repair

3.2.1 Hold spindle by skirt O.D. in soft jaw vise and replace seat.

3.2.2 Examine nozzle and polish seating surface as required. Replace if necessary.

#### 3.3 Assembly

Assemble in reverse order of disassembly. Do not lubricate spindle or guide. Make sure the guide plugs, if used, are flush or below the top guide surface. Refer to Table for plug requirements. Make sure nozzle is fully and evenly seated in guide. This is a press fit joint. Lubricate threads and adjusting bolt tip.

Orifice	Set pressure (Psig)	Quantity
F	Above 354	2
G	Above 223	2
H	Above 227	3
J	Above 142	3

#### 3.4 Soft goods repair kit

The part numbers for soft goods repair kits are listed below. Each kit contains the seat and seals for all pressure ranges indicated.

Orifice	TFE/KEL-F	Set pressure range		VESPEL	Set pressure range	
		Psig	Kpag		Psig	Kpag
F	04-4805-007	20-750	138-5171	04-4805-008	751 & up	5178 & up
G	04-4805-009	20-750	138-5171	04-4805-010	751 & up	5178 & up
H	04-4805-011	20-750	138-5171	04-4805-012	751 & up	5178 & up
J	04-4805-013	20-750	138-5171	04-4805-014	751 & up	5178 & up

# Maintenance Instructions

## Type 81 Spring Operated Pressure Relief Valves

### 4.0 Valve adjustment

#### 4.1 General

Two adjustments are provided on gas service valves, one for adjusting the opening pressure and one for adjusting the closing pressure.

#### 4.2 Set pressure

Turn spring adjustment screw on bonnet in most of the way. Increase pressure to desired level and back out screw until valve pops. Lock screw with jam nut and retest. Readjust as required.

#### 4.3 Reseat pressure

To adjust blowdown, turn screw IN to shorten blowdown; OUT to increase blowdown.

**Note:** If volume of test set up is too small, blowdown will be set too short even though pressure gauge indicates it to be correct. Refer to Section 4.5.

#### 4.4 Adjustments tolerances

##### Set pressure range

(psig)	Kpag	Valve operating characteristic	Tolerance*
Above 70	Above 483	Set Pressure	+/- 3%
70 & below	483 & below	Set Pressure	+/- 2 psi
100 & above	689 & above	Cracking Pressure	95%
50 to 99	345 to 683	Cracking Pressure	90 %
Below 50	Below 345	Cracking Pressure	85%
100 & Above	689 & above	Reseat Pressure	93%
50 to 99	345 to 683	Reseat Pressure	90%
Below 50	Below 345	Reseat Pressure	80%

\* Percent tolerance is of specified set pressure

#### 4.5 Adjusting equipment

Where practical, valves should be set using an accumulator large enough to accurately read and set blowdown. For a -4 orifice up to 4000 psig [27579 KPAG], -6 orifice up to 1410 psig [9722 KPAG] and a -8 orifice up to 600 psig [4137 KPAG], a four cubic foot [0.113 m<sup>3</sup>] accumulator is recommended. The supply pipe to the valve should be the same size as the inlet or larger and not more than 10" [254 mm] long.

For all other valves, or if an accumulator is not available for the sizes listed above, the blowdown may be set using the following method.

Turn the blowdown adjusting bolt all the way in until it just touches the guide, then turn it out the number of turns listed in the table.

##### Blowdown adjustment

Orifice	Turns out of blowdown screw	Set pressure range	
		Psig	Kpag
-4	1	20-4000	138-27579
	1 1/2	Above 4000	Above 27579
-6	3/4	20-1410	138-9722
	1 1/4	Above 1410	Above 9722
-8	1 1/2	20-600	138-4137
	2 1/2	Above 600	Above 4137
-F	1	20-700	138-4826
	1 1/2	Above 700	Above 4826
-G	1 3/4	20-700	138-4826
	2 1/4	Above 700	Above 4826
-H & -J	3/4	20-700	138-4826
	1 1/2	Above 700	Above 4826

### 6.0 Set pressure change

If the set pressure is changed more than +/- 5% from the nameplate set pressure, the spring, spring washers, spring bonnet, guide plugs and seat may also have to be changed. Consult the factory or refer to the soft goods repair kit, the table in section 3.3 and spring chart 03.0079.

### 5.0 Seat leakage

#### 5.1 General

If the valve leaks after repair check the following:

- 5.1.1 Full and even seating of nozzle and guide.
- 5.1.2 Foreign particles trapped between the seat and nozzle. If any are found they may have damaged the seat, making it necessary to replace it.
- 5.1.3 Correct seat material for the valve set pressure.

If items 1 and 2 reveal no evident seat leakage source, the procedures described in Section 5.2 may be used to eliminate seat leakage. Section 5.2 applies only to teflon seated -4, -6, or -8 orifice Type 81's with nameplate set pressures that do not exceed 300 psig [2068 KPAG].

#### 5.2 Seat sealing procedures

Heat the valve for 15 to 30 minutes in a oven preheated to 250-300°F [121-149°C].

A concentrated heat source such as a heat gun or open flame must not be used.

After the valve has air-cooled to room temperature, retest per Section 4.0 to insure seat tightness. If results have not improved, the valve should be disassembled and the seat replaced.